

| REVISION HISTORY |      |               |            |
|------------------|------|---------------|------------|
| DATE             | REV. | DESCRIPTION   | BY         |
| 29-02-2024       | A    | First release | LTousgaard |

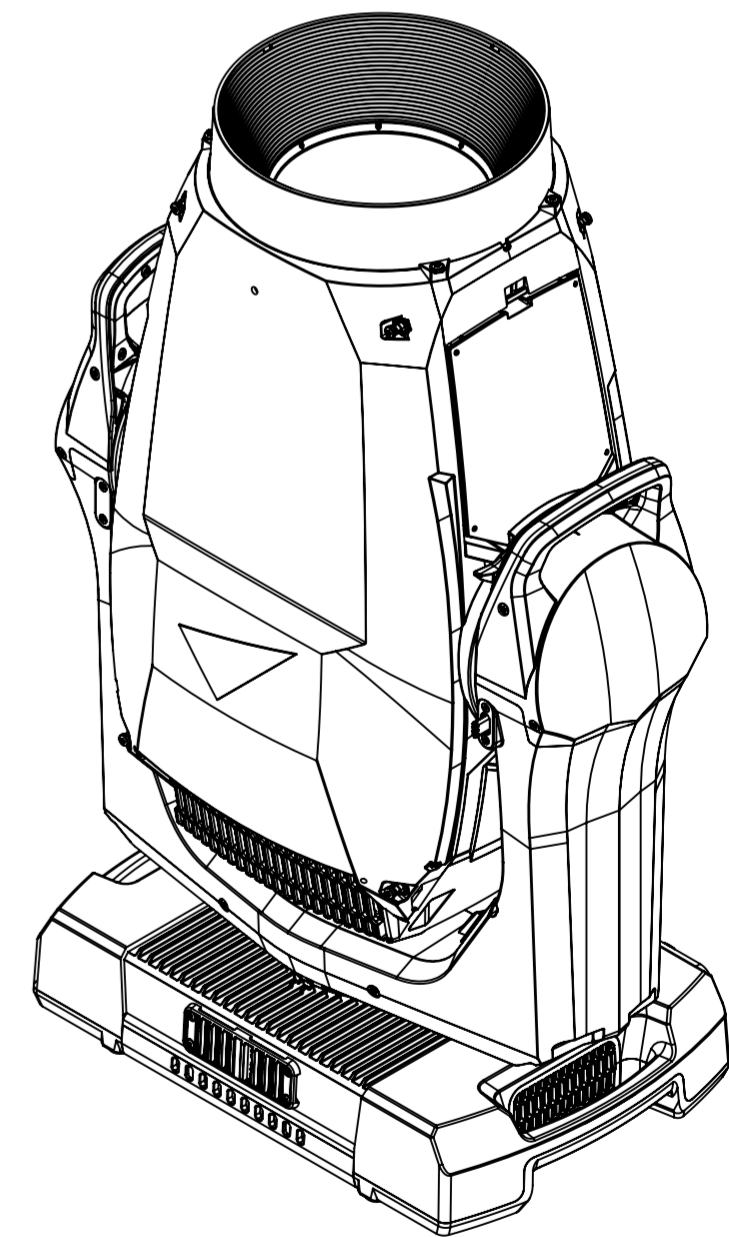
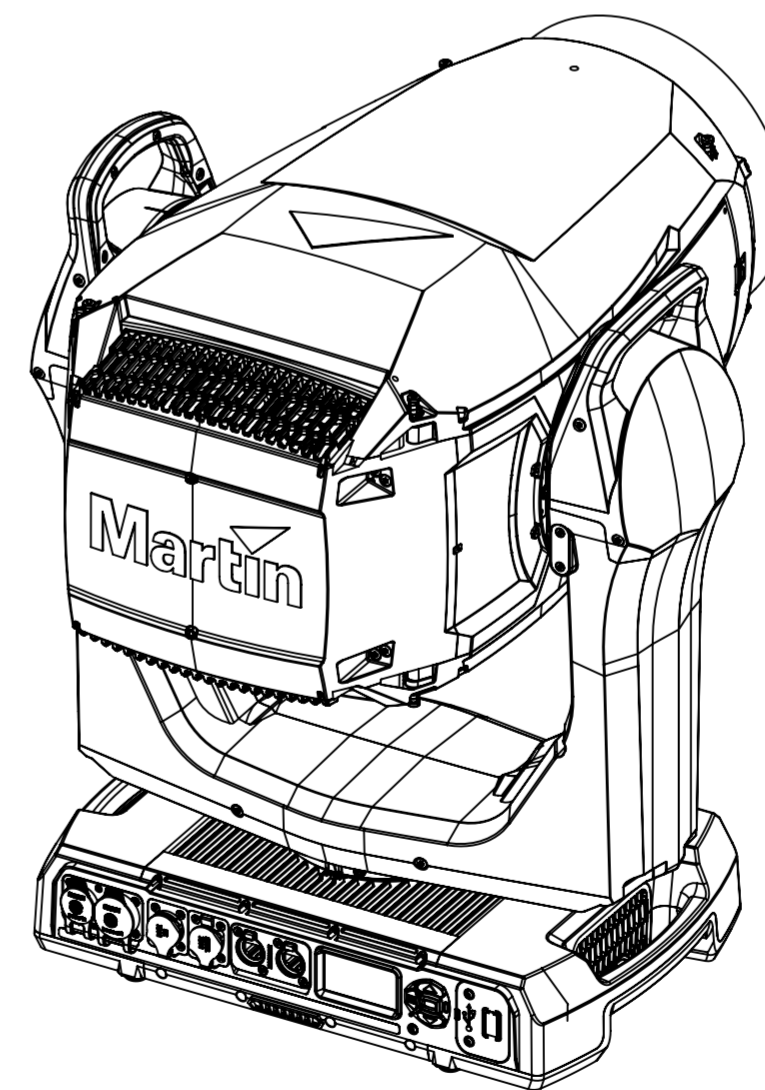
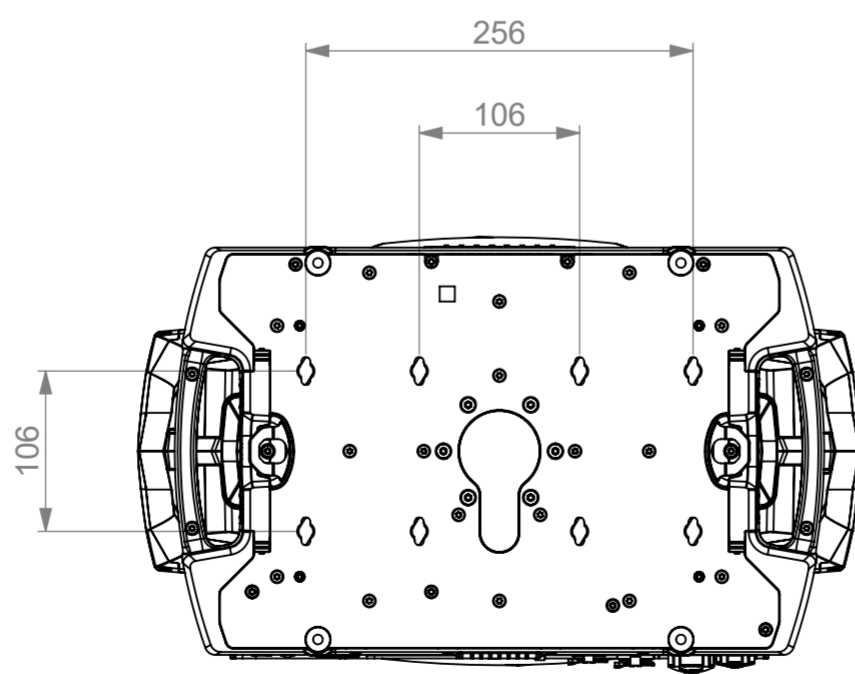
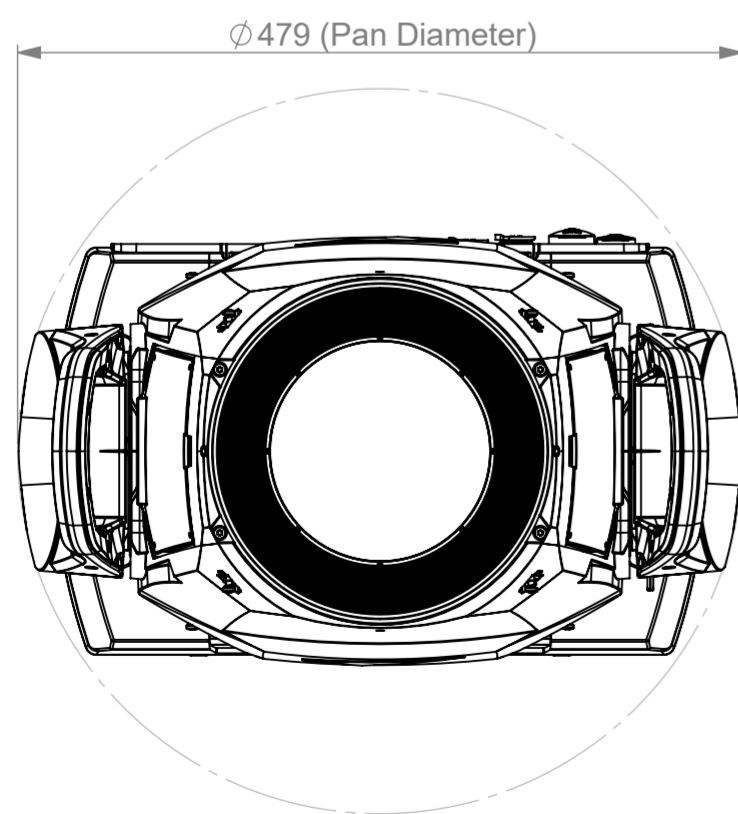
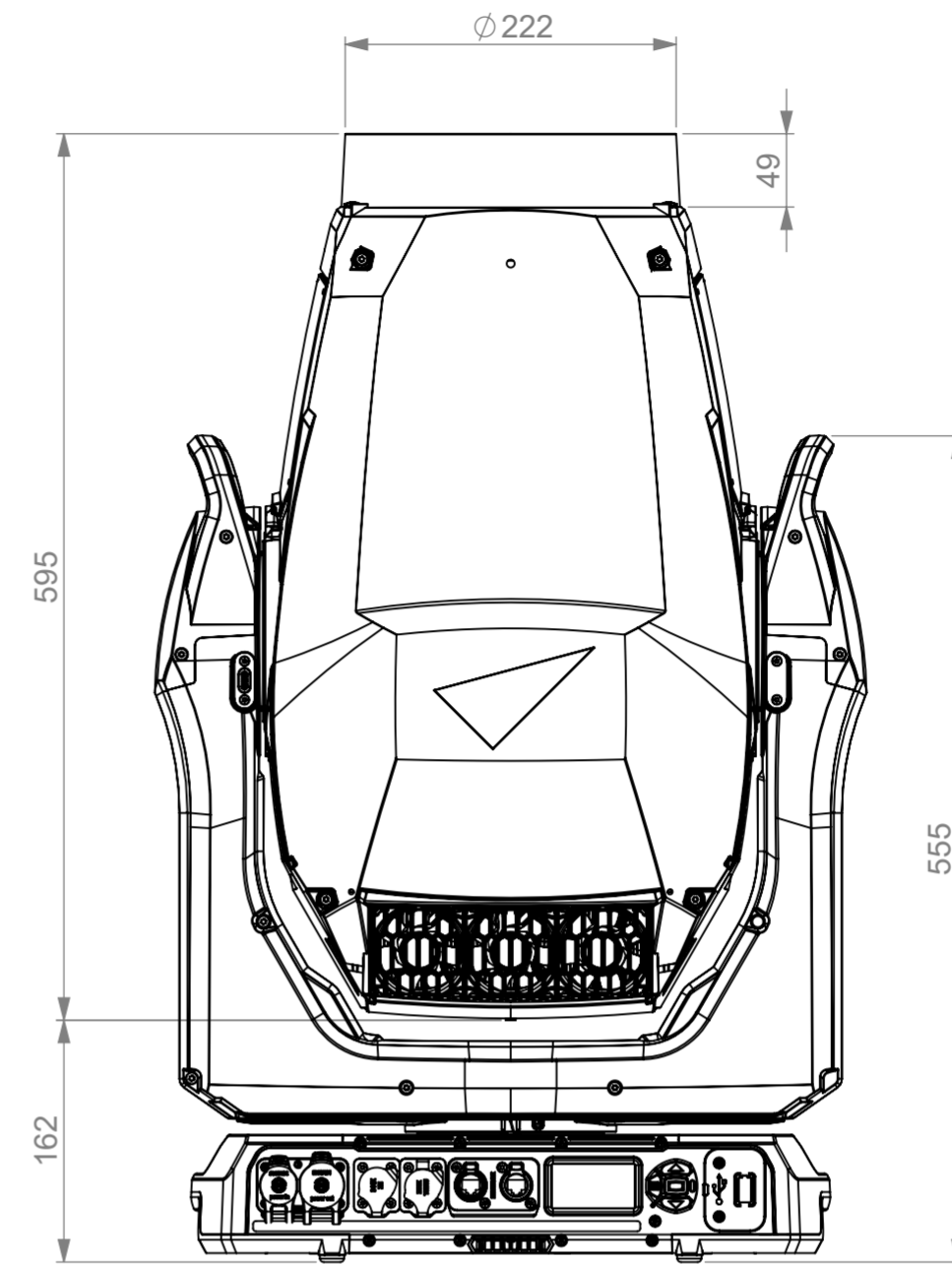
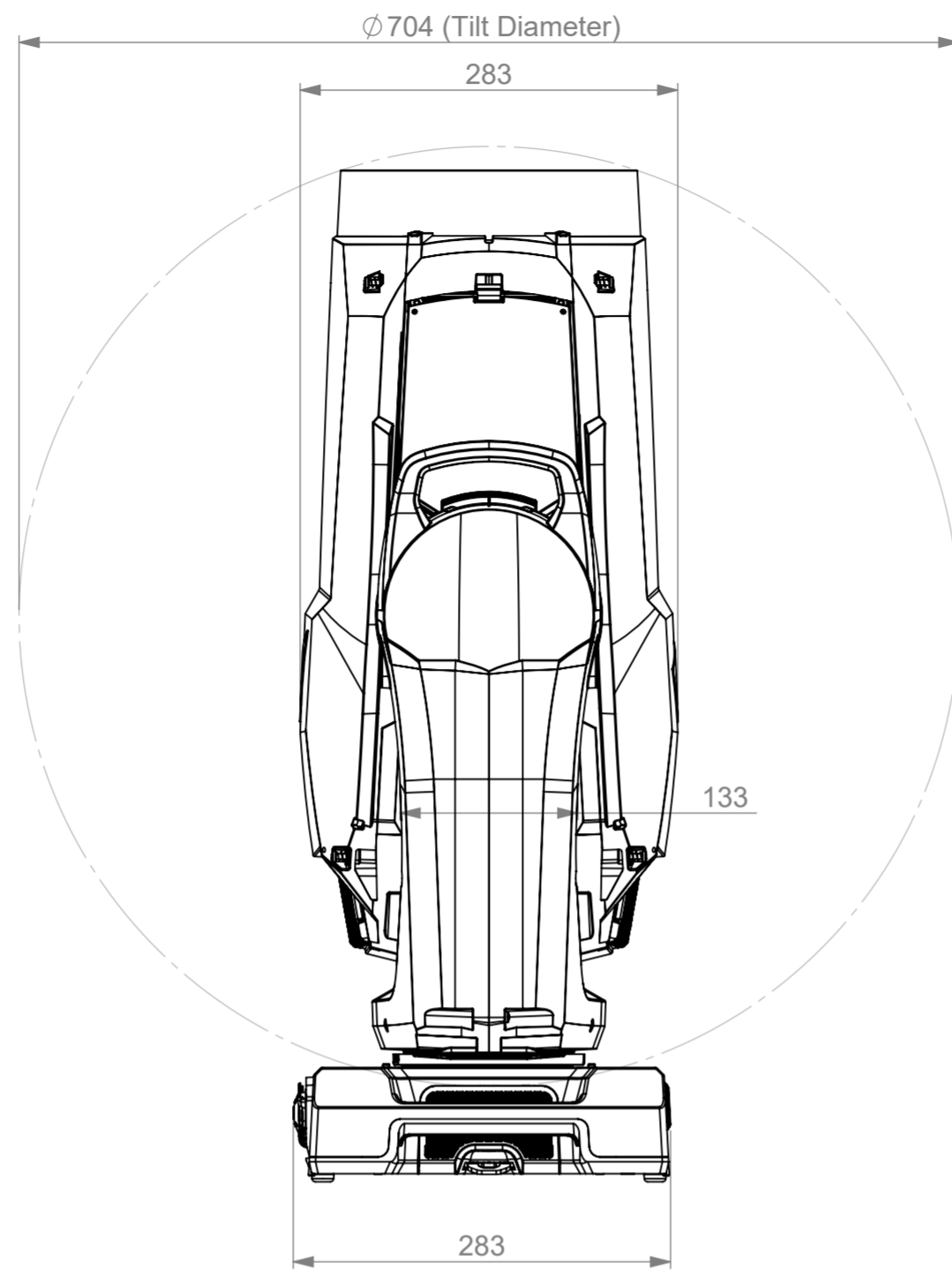
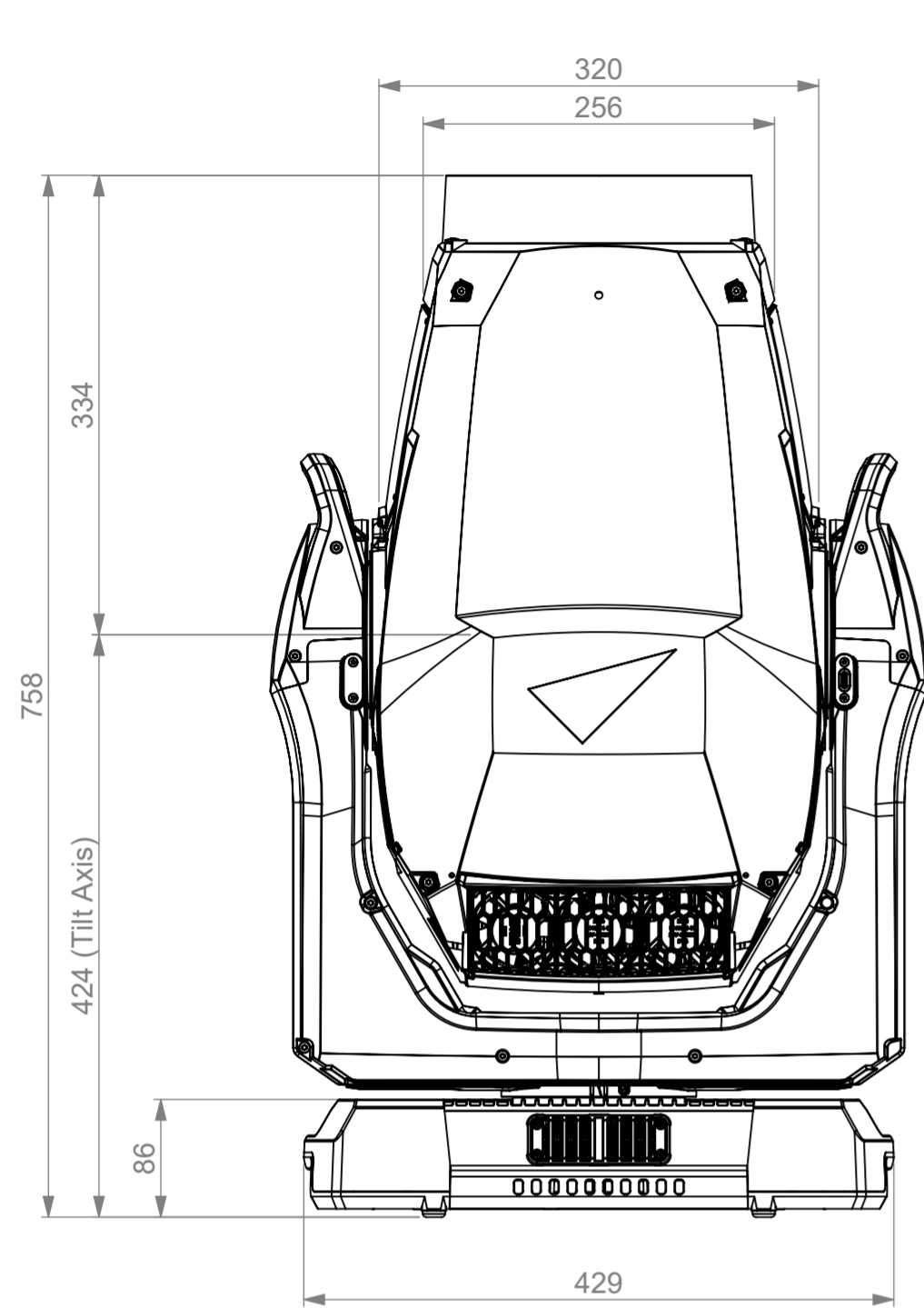

|  |  |                                   |   |   |
|--|--|-----------------------------------|---|---|
| © 2024 HARMAN Professional Denmark ApS<br>PROPRIETARY AND CONFIDENTIAL PROPERTY OF<br>HARMAN. DO NOT DISCLOSE, REPRODUCE, OR<br>PUBLISH WITHOUT WRITTEN HARMAN APPROVAL.                               | Material   | <b>FIRST ANGLE PROJECTION</b><br> |   | HARMAN Professional<br>Denmark ApS<br>Olof Palmes Allé 44<br>DK 8200 Aarhus N |
|  | General linear tolerance   |                                   |   |   |
| <b>ROHS</b><br>RESTRICTION OF HAZARDOUS SUBSTANCES<br>ALL MATERIALS USED IN THIS PART MUST BE<br>ROHS COMPLIANT.<br>SUPPLIER SHALL PROVIDE A CERTIFICATE OF ROHS<br>COMPLIANCE WITH THE FIRST ARTICLE. | General angular tolerance  | Color                             | TITLE<br><b>MAC Viper XIP</b>                       |   |
|  | General geometrical tolerance  | Project number<br>30300           | NO. <span style="float: right;">REV <b>A</b></span> |   |
|  | DIMENSIONS SHOWN ARE FOR REFERENCE AND INSPECTION<br>ONLY. REFER TO CAD MODEL PROVIDED WITH THIS DRAWING<br>FOR OVERALL DEFINITION OF PART GEOMETRY. |                                   | SIZE <b>A2</b> SCALE <b>1:5</b> UNIT <b>mm</b>      | DO NOT SCALE DRAWING    SHEET <b>1</b> OF <b>1</b>                            |