

martinarchitectural



Exterior 1200 Wash user manual

Martin

Dimensions

Measurements are in millimeters

Luminaire

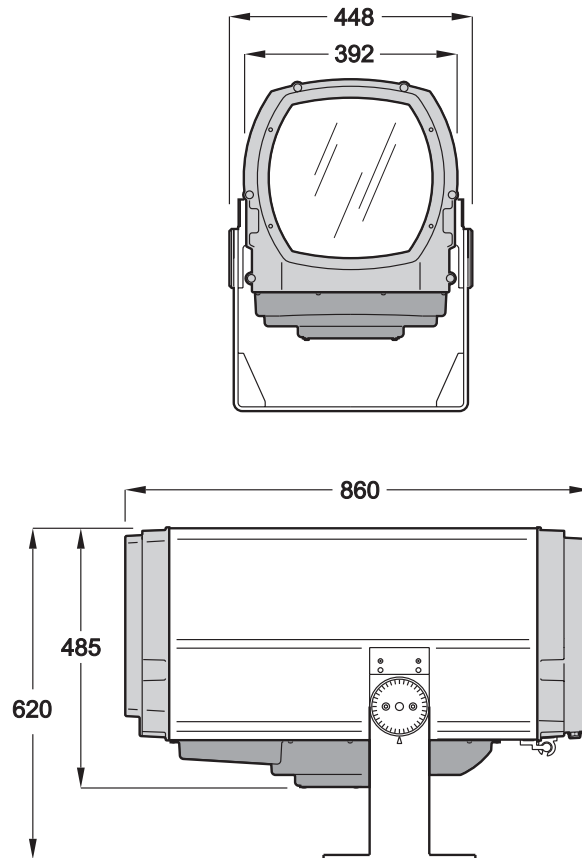

Mounting yoke base

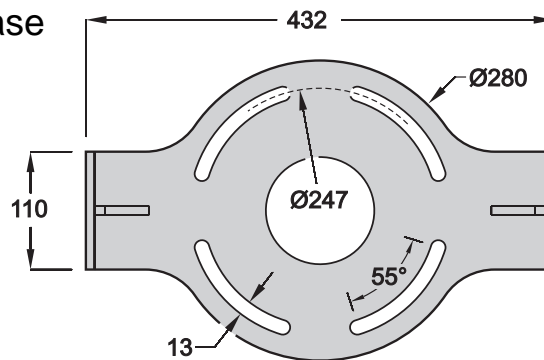

Martin

© 2006 Martin Professional A/S. All rights reserved. No part of this manual may be reproduced, in any form or by any means, without permission in writing from Martin Professional A/S. Information subject to change without notice. Martin Professional A/S and all affiliated companies disclaim liability for any injury, damage, direct or indirect loss, consequential or economic loss or any other loss occasioned by the use of, inability to use or reliance on the information contained in this manual. Please check with your Martin Architectural supplier that you have the latest product information before installing or servicing this product.

P/N 35000177 Rev. C

Section 1. Safety

1.1 Safety information

 **WARNING!**
Read the safety precautions in this section before installing, powering, operating or servicing this product.



The following symbols are used to identify important safety information on the product and in this manual:

						
DANGER! Safety hazard. Risk of severe injury or death.	DANGER! Refer to user manual for important safety information.	DANGER! Hazardous voltage. Risk of lethal or severe electric shock.	DANGER! Fire hazard.	Warning! Burn hazard. Hot surface. Do not touch.	Warning! Risk of eye injury. Safety glasses must be worn.	Warning! Risk of hand injury. Safety gloves must be worn.

 **DANGER!** This product is for professional use only. It is not for household use. If safety precautions are not followed, it presents risks of injury due to electric shock, heat and ultraviolet radiation burns, lamp explosion, falls, high-intensity light, and fire.

 Read this manual before installing, powering, operating or servicing the luminaire. Follow the safety precautions listed below, and observe all warnings in this manual and on the luminaire. Use the luminaire only as described in this manual and in accordance with local laws and regulations. Refer any operation not described in this manual to a qualified technician.

Electrical safety

-  Do not use the luminaire if any cable, component or cover is damaged, cracked or deformed.
-  Switch the lamp off, allow the luminaire to cool with fans running for 20 minutes, then isolate it from AC power and lock out power before removing or installing the lamp, fuses, or any part.
- Ensure that the luminaire is correctly configured for the local AC power voltage as described in this manual before applying power for the first time.
- Always ground (earth) the luminaire electrically.
- Use only a source of AC power that complies with local building and electrical codes and has both overload and ground fault (earth fault) protection.

- Ensure that the AC power distribution system includes a means of isolating all installed devices from power and locking out power during service.
- Ensure that all components in the AC power distribution circuits (cables, junction boxes, etc.) are protected from water and airborne particles to IP67 or higher, are suitably dimensioned for the current and power requirements of the devices installed, and are of suitable type for the location (including water, pollution, temperature and UV resistance).
- Do not expose any part of the luminaire to a high-pressure water jet.
- Do not expose the heat exchanger to water projections.
- Do not immerse the luminaire in water or any other fluid, or install it in a location where flooding may occur.
- Refer all service not described in this manual to a Martin service technician.

Lamp safety



- Do not operate the luminaire with missing or damaged covers, shields, lenses or ultraviolet screens: an unshielded discharge lamp emits UV radiation that can cause burns and eye damage.



- Do not stare directly into the light output. Never look at an exposed lamp while it is lit.
- A hot discharge lamp is under pressure and can explode without warning. Allow the luminaire to cool for at least 20 minutes and protect yourself with safety glasses and safety gloves before replacing the lamp or servicing the luminaire internals.



- If the quartz envelope of a discharge lamp is broken, the lamp releases a small quantity of mercury and other toxic gases. If a discharge lamp explodes in a confined area, evacuate the area and ventilate it thoroughly. Wear non-porous safety gloves when handling a broken discharge lamp. Treat broken or used discharge lamps and used safety gloves as hazardous waste and send to a specialist for disposal.
- Replace the lamp if it becomes visually deformed, damaged or in any way defective
- Replace the lamp at the latest when it reaches the limit of its average life as specified in this manual or by the lamp manufacturer.
- Install only an approved lamp.

Protection from burns and fire



- Do not operate the luminaire if the ambient temperature (T_a) exceeds 45° C (113° F).
- The exterior of the luminaire becomes hot, up to 90° C (194° F) during normal operation. Ensure that accidental physical contact with an installed luminaire is impossible.



- Keep flammable materials well away from the luminaire.
- Keep all combustible materials (for example fabric, wood, paper) at least 1 m (40 in.) away from the luminaire.
- Do not illuminate surfaces within 1 m (40 in.) of the luminaire.
- Allow the luminaire to cool for 20 minutes before servicing.
- Do not attempt to bypass thermostatic switches or fuses. Replace defective fuses with ones of the specified type and rating only.
- Do not modify the luminaire in any way not described in this manual.
- Install only genuine Martin parts and approved lamps.
- Provide a minimum clearance of 135 mm (5.5 in.) and ensure unobstructed airflow around the air vents in the heat exchanger cowling.
- Provide a minimum clearance of 150 mm (6 in.) between the top of the luminaire and any part of a building above the luminaire.
- Provide a minimum clearance of 400 mm (16 in.) between the center of the luminaire and any part of a building to the side of the luminaire.

- Provide a minimum center-to-center distance of 800 mm (31.5 in.) between Exterior 1200 Wash luminaires.
- Install the luminaire outdoors or in a well ventilated area.
- Do not place filters or other materials over the lens. Use only Martin approved accessories to mask or modify the light beam.



Preventing injury due to falls and while lifting

- Ensure that all external covers, components and installation fittings are securely fastened.
- The luminaire weighs 68 kg (150 lbs.). At least two people are required to lift, move and adjust it. Do not attempt to lift the luminaire or adjust the beam angle alone.
- Block access below the work area and work from a stable platform whenever installing, servicing or moving the luminaire.
- Ensure that all supporting structures, surfaces, fasteners and lifting equipment can bear the weight of all the devices they are intended to support plus an adequate safety margin, and that they conform to local building and safety regulations.
- Use a sufficient number of fasteners with sufficient corrosion resistance, dimensions and strength to mount the luminaire safely. Any nuts used must be self-locking. The washers supplied with the luminaire must be installed directly under the fasteners' heads when anchoring the yoke base to the installation surface.
- The four eyebolts supplied are for lifting purposes during installation or service only. Do not expose them to undue stress while lifting, by allowing the luminaire to drop and then catching it again, for example. Do not use the eyebolts for safety attachment.

Contents

Section 1. Safety	3
1.1 Safety information	4
Section 2. Introduction	9
2.1 About this manual	10
2.2 Introduction to the Exterior 1200 Wash	11
Section 3. Installation	13
3.1 Physical installation	14
3.1.1 Unpacking	14
3.1.2 Location and mounting	15
3.1.3 Power and DMX data cable layout	17
3.1.4 Connections compartment access	18
3.2 Installing AC power	19
3.2.1 Configuring for local AC power	19
3.2.2 Connecting to AC power	20
3.3 Installing a data link	22
3.3.1 Planning the data link	22
3.3.2 Building the data link	22
Section 4. General	25
4.1 General	26
4.1.1 Powering on	26
4.1.2 Powering off	26
4.1.3 Lamp operation	26
4.1.4 'Exercise Program' at lamp off	27
4.1.5 Onboard control panel	27
4.1.6 Cooling fans	28
4.1.7 Operating in hot environments	28
4.1.8 Operating in cold environments	29
4.1.9 LEDs and operating status	29
Section 5. Settings and configuration	31
5.1 Luminaire settings	32
5.1.1 Setting up a luminaire with a PC and MUM	33
5.1.2 Setting up a luminaire with an MP-2	36
5.1.3 Setting up a luminaire with the onboard control panel	37
Section 6: Stand-alone operation	39
6.1 Stand-alone programming: general	40
6.1.1 Introduction	40
6.1.2 Synchronized operation with multiple luminaires	40
6.1.3 Stand-alone programming methods	42
6.2 Stand-alone programming with a PC and MUM	43
6.2.1 Connecting	43
6.2.2 Stand-alone settings	44
6.2.3 Programming effects in scenes	45
6.2.4 Programming the same stand-alone show on multiple luminaires ..	47

6.3 Stand-alone operation	48
6.3.1 Starting show playback automatically at luminaire power-on	48
6.3.2 DMX controller override during stand-alone show playback.	48
Section 7. DMX control	49
7.1 Preparing for DMX control	50
7.1.1 Setting DMX addresses	50
7.1.2 DMX Lamp Off option	51
7.1.3 DMX Reset option.	51
7.2 DMX controller operation	52
7.2.1 Effect operation.	52
7.2.2 Lamp	52
7.2.3 Color	53
7.2.4 Dimmer	53
7.2.5 Zoom.	53
7.2.6 Effects speed (tracking and vector control)	53
Section 8. Service and accessories	55
8.1 Service: general	56
8.2 Beam adjustment	56
8.3 Cleaning	57
8.3.1 Cleaning the heat exchanger	57
8.3.2 Cleaning the housing and front glass	58
8.4 Seals and cable glands	58
8.4.1 Seals	58
8.4.2 Cable glands	59
8.4.3 Torque settings	60
8.5 Lamp maintenance	61
8.5.1 Approved lamp	61
8.5.2 Lamp life and monitoring lamp hours	61
8.5.3 Installing the lamp	62
8.6 Installing color filters	64
8.7 Replacing fuses	66
8.8 Software-based service functions	67
8.8.1 Adjustment and monitoring	67
8.8.2 Restoring factory defaults	67
8.8.3 Software updates	68
8.9 Troubleshooting	69
8.10 Accessories	70
Section 9. Reference	71
9.1 Connections compartment	72
9.2 LED status messages	73
9.3 Onboard control panel menus	74
9.4 MP-2 control menus	75
9.5 DMX protocol	77
Exterior 1200 Wash specifications	78

Section 2. Introduction

2.1 About this manual

This user manual is organized into sections. Depending on whether you are installing, programming or operating the product, and depending on the method and hardware used to configure and operate the product, you probably do not need to read every section.

The outline below should help you see which sections are relevant to you:

Section	Contents	Who needs to read it
Section 1. Safety, page 3	Vital safety information	All
Section 2. Introduction, page 9	Brief overview of the product	All
Section 3. Installation, page 13	Instructions for: Physical installation Installing AC power Installing a data/DMX link	Installer (physical installer, installation electrician, data/DMX system installer)
Section 4. General, page 25	Main features and functions as well as programming and operating principles	All involved in programming and operating
Section 5. Settings and configuration, page 31	Instructions for carrying out basic configuration	All involved in programming and operating
Section 6: Stand-alone operation, page 39	Instructions for setting up and running stand-alone operation	Programmer and operator, if stand-alone operation used
Section 7. DMX control, page 49	Instructions for setting up and using DMX control	Programmer and operator, if DMX control used
Section 8. Service and accessories, page 55	Service, maintenance and adjustment procedures. Overview of accessories.	Owner, service technician
Section 9. Reference, page 71	Reference diagrams, charts, etc.	All
Exterior 1200 Wash specifications, page 78	Product specifications	All

Table 1: Using this manual

2.2 Introduction to the Exterior 1200 Wash

Thank you for selecting the Exterior 1200 Wash from Martin Architectural. This automated luminaire combines dynamic architectural lighting effects with extremely bright output in an aluminum housing designed for permanent outdoor installation. The luminaire uses a Philips MSD 1200 metal halide discharge lamp with an average lamp life of 3000 hours. An air/air heat exchanger system ensures effective cooling.

All models feature independently variable 0 - 100% cyan, magenta and yellow (CMY) color mixing as well as a color wheel with red, green and blue dichroic color filters and a 5500 to 3400 K dichroic color temperature correction (CTC) filter installed as standard. All models feature full-range continuous dimming.

The beam angles of Narrow and Medium models can be controlled remotely using a motorized zoom feature.

The Exterior 1200 Wash is available in the following optical configurations (figures are for one-tenth peak beam angles, ranges indicate minimum and maximum zoom limits):

- Narrow: 14° - 31°
- Medium: 20° - 50°
- Wide: 60°
- Very Wide: 97°

All dynamic effects can be controlled using industry-standard DMX intelligent lighting control technology or run independent or synchronized stand-alone light shows that do not require external control. Stand-alone light show start and stop times can either be programmed using the luminaire's onboard clock or triggered by ambient light level within programmed times.

Snoot and barndoors kits are available as accessories for all models. When mounted on the front of a luminaire, snoots and barndoors allow control of both beam shape and glare. A beam shaper lens available as an accessory for Narrow and Medium models, optically modifies output to give an elliptical beam.

A permanent CTC filter is also available as an accessory. The permanent filter allows precise color matching with other luminaires with different lamps.

This advanced product requires regular service and maintenance in order to ensure optimum operation and protect the investment it represents. Installation, on-site service and maintenance can be provided worldwide by the Martin Global Service organization and its authorized agents. Choosing a Martin service contract gives owners access to Martin's expertise and product knowledge in a partnership that will ensure the highest level of performance throughout the product's lifetime.

Section 3. Installation

3.1 Physical installation



DANGER! Read "*Safety information*" on page 4 before installing the Exterior 1200 Wash.

Warning! The safety and suitability of lifting equipment, installation location, anchoring method, mounting hardware and electrical installation is the responsibility of the installer. All local safety regulations and legal requirements must be observed when installing and connecting the Exterior 1200 Wash. Installation must be carried out by qualified professionals only.

Contact your Martin Architectural supplier for assistance if you have any questions about how to install this product safely.

3.1.1 Unpacking

The Exterior 1200 Wash is supplied with the following items:

- Mounting yoke.
- Cable glands for power and control cable entry.
- Blanking plugs (installed) for sealing unused cable entry holes.
- User manual.

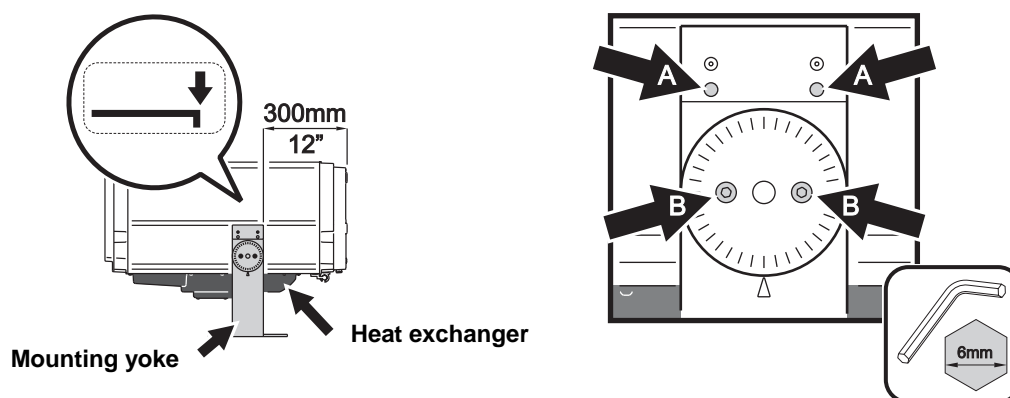

Figure 1: Mounting yoke adjustment

See Figure 1. The mounting yoke is folded back for shipment. When the luminaire has been unpacked:

1. Supporting the luminaire's weight, rest it on its top (the opposite surface to the heat exchanger) and use an Allen key to loosen the yoke clamp locking screws (**A**) and tilt lock screws (**B**) on each side of the yoke.
2. Fold the yoke around to the bottom of the fixture (normally the side with the heat exchanger), and slide the yoke forwards until the edge of the yoke lines up with the mark (arrowed) on the label on the side of the luminaire. In this position, the edge of the yoke is 300 mm (12 in.) from the end of the luminaire and the luminaire's weight is balanced in the yoke.
3. Tighten the yoke clamp locking screws and tilt lock screws to approximately 16 Nm (11.8 ft.-lbs.).

3.1.2 Location and mounting



DANGER! Read "*Safety information*" on page 4 before attempting to install this product.

Installation will probably be easiest if the lamp is installed before installing the luminaire (see "8.5.3: *Installing the lamp*" on page 62).

Lifting



DANGER! Use only the lifting eyebolts provided to lift the luminaire. Eyebolts must be securely installed with washers at all four corners of the luminaire as illustrated below.

See Figure 2. The Exterior 1200 Wash is supplied with four eyebolts for lifting purposes during installation or service. Do not use any other method to lift the luminaire. The eyebolts screw into blocks in the yoke slider channels on each side of the fixture. Use the supplied washers to avoid damage to the luminaire housing. Make sure that eyebolts are firmly screwed in and will not slide in the channels before attempting to lift the luminaire.

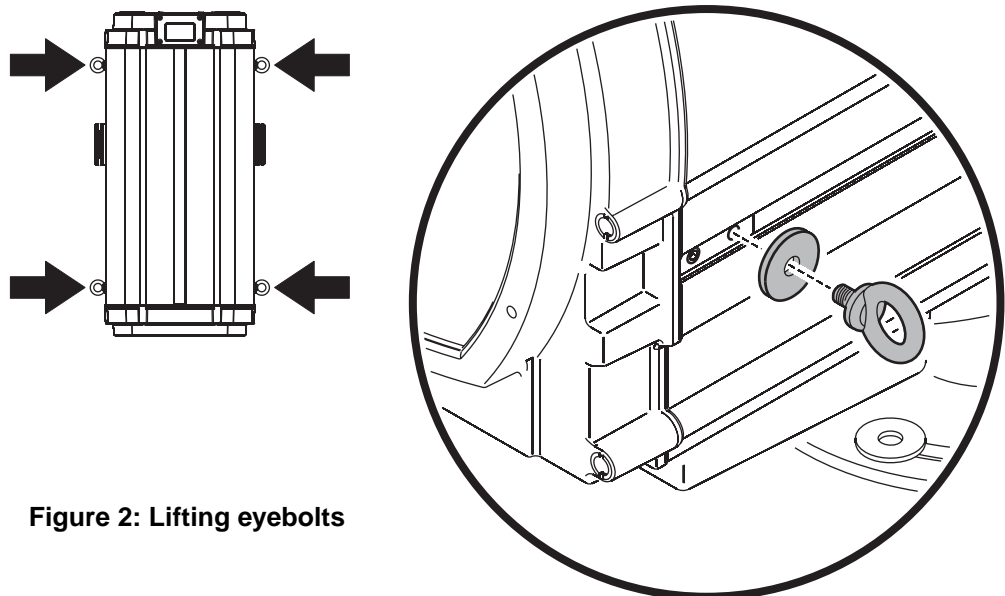

Figure 2: Lifting eyebolts

Do not expose the eyebolts to undue stress while lifting, by allowing the luminaire to drop and then catching it again, for example. Do not use the eyebolts for safety attachment.

Location and orientation



DANGER! The Exterior 1200 Wash mounting yoke base must be securely anchored to a suitable flat surface. Ensure that the supporting structure can bear the weight of all installed devices plus an adequate safety margin.

Consult a qualified engineer to determine a suitable anchoring method and to verify that the structure can safely bear the luminaire's weight.

The Exterior 1200 Wash is rated UL Wet Location. When choosing a location for installation, consider that the main housing has an ingress protection (IP) rating of 65, but that the heat exchanger unit must be protected from rain or direct water projections that might fill the heat exchanger with water and cause overheating. The luminaire may therefore be installed in any orientation, but it must be positioned so that the heat exchanger is on the lower side of the luminaire (see Figure 3). If necessary, loosen the yoke tilt lock screws (**B** in Figure 1) and reposition the yoke.

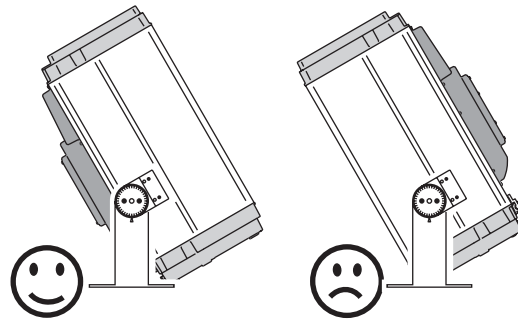

Figure 3:
Heat exchanger position

Allow for service access to the front and rear of the luminaire.

The Exterior 1200 Wash can be installed outdoors but:

- Do not expose it to high-pressure water jets from any direction
- Do not immerse it in water (or any other fluid)
- Do not install it in a location where flooding may occur.

Ensure sufficient drainage to cope with the heaviest rainfall. Make sure that water can drain away from the installation area at least as fast as it can enter it.

The Exterior 1200 Wash requires free and unobstructed airflow around the heat exchanger to ensure adequate cooling:

- Do not bury the luminaire or locate it in an unventilated space
- Allow 135 mm (5.5 in.) free space around the heat exchanger
- Make sure that leaves, litter or other debris cannot be sucked into the heat exchanger, as blockages may cause overheating and result in damage that is not covered by the product warranty.

Install the luminaire at least 1 m (40 in.) away from the surface to be illuminated and any combustible materials (wood, paper, etc.) and well away from any flammable materials.

The aluminum housing reaches temperatures up to 90° C (194° F). Restrict public access or locate the luminaire so that it cannot accidentally be touched.

Mounting fasteners



DANGER! All fasteners used to mount the Exterior 1200 Wash must be corrosion-resistant and strong enough to mount the luminaire safely.

The mounting yoke allows the luminaire to be manually panned (i.e. rotated horizontally) and tilted for beam aiming adjustment. The yoke base must be safely anchored to a horizontal surface. The number and type of fasteners used will depend on the installation, but use at least four high-strength corrosion-resistant fasteners (recommended minimum properties: A4-70 grade according to ISO 3506 or grade 8.8 according to according to ISO 898-1) evenly distributed around the yoke base. Any nuts used must be self-locking. The washers supplied with the luminaire must be installed between the head of each fastener and the yoke base.

To mount the luminaire, evenly space 12 mm (1/2 inch) thread diameter bolts at 90° intervals on a 123.5 mm (4.86 inch) radius from the center of the mounting location, so

that one bolt passes through each curved slot in the yoke base (see Figure 4). If additional bolts are required to mount the luminaire safely, pan adjustment range will be reduced.

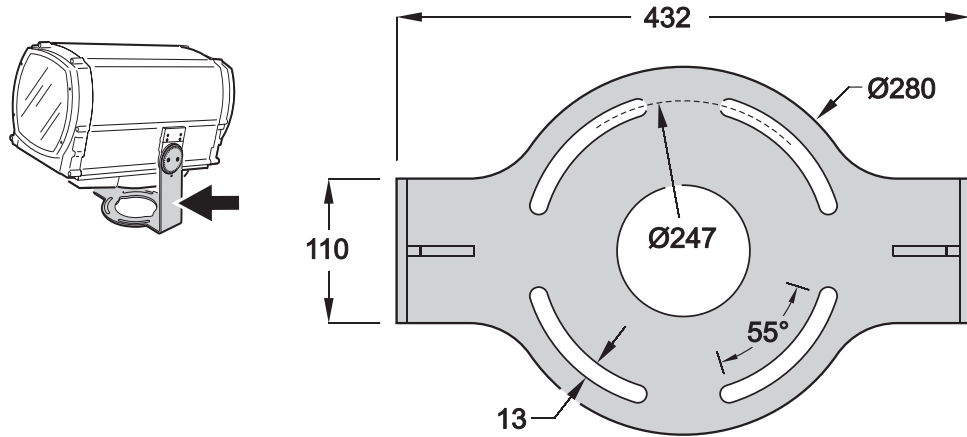

Figure 4: Mounting yoke attachment points

3.1.3 Power and DMX data cable layout

Figure 5 gives an overview of a suitable cable layout. The dotted lines represent AC power circuits. The solid lines represent the data link.

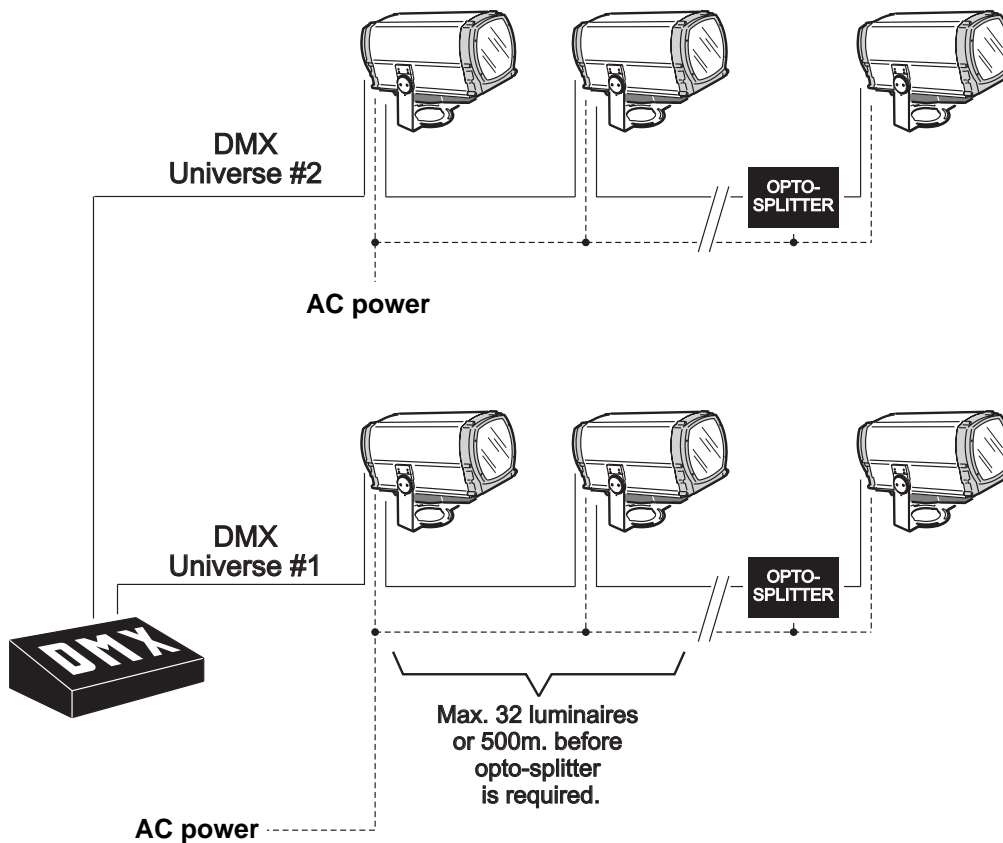

Figure 5: Schematic cable layout diagram

3.1.4 Connections compartment access



DANGER! Fuseholders remain live even if the MAINS switch is set to off. Cut power to the luminaire before changing a fuse.

To gain access to the connections compartment:

1. If the luminaire has been in use, allow it to cool completely.
2. If you intend to open a main fuseholder, cut AC power to the luminaire and ensure that power cannot be reapplied accidentally by locking it out.
3. See Figure 6. Loosen the screws in the rear cover plate and carefully remove the plate and seal.
4. If you intend to alter any connections, shut down AC power by setting the MAINS switch to **0** (off). Before you touch any connectors, use a tester to check that they are not live.

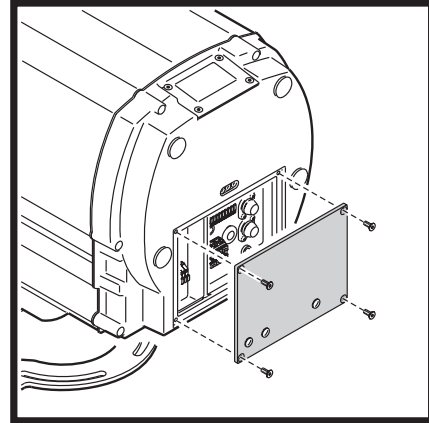

Figure 6: Connections compartment cover plate

After access to the connections compartment:

1. Check the condition of the rear cover seal. Replace with a new item if the seal is torn, cracked or brittle.
2. Hold the rear cover plate and seal firmly against the luminaire housing. Adjust the sides of the seal so that the seal sticks out a little, just enough so that you can feel the seal when you run a finger across the joint.
3. Cross-tighten the cover plate screws gradually and evenly to 2 Nm (1.5 ft.-lbs.). At this torque, the seal will be compressed by about one-third and will be waterproof to IP65.

3.2 Installing AC power



DANGER! Read "*Safety information*" on page 4 before attempting to install this product.

Electrical installation must be carried out by qualified professionals only.

For protection from dangerous electric shock, the luminaire must be grounded (earthed). The AC power distribution system must be fitted with current overload and ground-fault (earth-fault) circuit breakers as well as a means to isolate luminaires from power and lock out power during service.

Important! Do not connect the Exterior 1200 Wash to an electrical dimmer system. Doing so can damage the electronics.

See Figure 5 on page 17 for a schematic diagram of cable layout.

If there is a break or cut at any point in a cable (for example at a connection point), and if this is exposed to water, moisture can be drawn up the inside of the cable due to the vacuum effect of temperature fluctuations during operation. Ensure that the luminaire is protected from the entry of water via the power cable by using IP65-rated connectors or junction boxes, or by protecting connectors with weatherproof housings.

The Exterior 1200 Wash must be supplied with power via an electrical cable that is adequately dimensioned for the current requirements and suitable for the installation environment, particularly with regard to water, pollution, thermal and UV resistance. Use Hypalon or neoprene rubber-jacket cable rated to 90° C (194° F) minimum. The conductor size must be 1.5 mm² (16 AWG) minimum. Check that all power cables are in perfect condition.

See "*Exterior 1200 Wash specifications*" on page 78 for details of fuse rating and typical current. If you require help in planning or dimensioning the power distribution system, please contact your Martin Architectural supplier for assistance.

Electrical power installation consists of two steps:

1. Configuring for local AC power
2. Connecting to AC power.

3.2.1 *Configuring for local AC power*

Before AC power is applied to the Exterior 1200 Wash for the first time (or if the AC power voltage or frequency changes), the luminaire must be configured to accept the local power voltage and frequency as described in this section.

The Exterior 1200 Wash can accept the following AC voltages and frequencies:

- 200 V, 208 V, 220 V, 230 V, 240 V, 250 V or 277 V at 50 or 60 Hz.

Operating at the incorrect power setting can result in overheating and damage to the luminaire and lamp. If your local power voltage differs from the voltage settings listed here and in the luminaire, contact your Martin Architectural supplier for assistance.

The luminaire must be configured to accept the local AC power frequency and voltage by connecting the free ends of two jumper leads. The fixed end of each lead sits in an orange terminal. The free end of each lead must be connected to the appropriate terminal on the terminal block. Terminals are labelled.

The terminals are spring-loaded, and leads can be released by exerting light pressure on the terminal tab with a flat-head screwdriver.

To configure the luminaire for local AC power:

1. Make sure that the luminaire is isolated from AC power and cannot be accidentally connected throughout the procedure.
2. Open the connections compartment as described in "3.1.4: Connections compartment access" on page 18.
3. See Figure 7. Connect the free end of the frequency setting jumper lead (in the section marked **Hz setting**) to the terminal labeled with the local AC power frequency.
4. Connect the free end of the voltage setting jumper lead (in the section marked **Volt setting**) to the terminal labeled with the local AC power voltage.

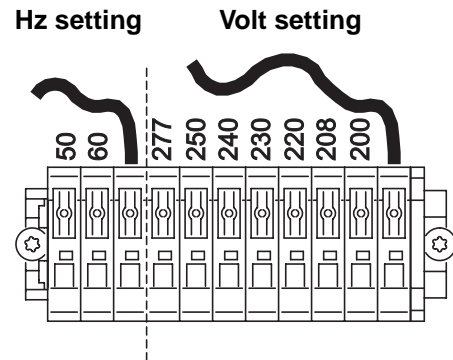

Figure 7: Frequency and voltage settings

3.2.2 Connecting to AC power

Power cable must enter the luminaire through an M20 x 1.5 cable gland that accepts 8 - 13 mm (0.32 - 0.5 in.) external diameter cables. A gland is supplied with the luminaire. The cable gland must be replaced if the power cable diameter is not within this range (see "8.4.2: Cable glands" on page 59).

One of two cable entry points can be used: either on the cover plate at the rear of the luminaire, or through the bottom of the connections/power compartment. Using the bottom of the connections/power compartment is recommended, as cables installed here will not be disturbed or flexed when the rear cover plate is removed for service. All cable entry/exit holes that are not used must be sealed with blanking plugs.

1. Make sure that the power cable is isolated from power and that power cannot be applied accidentally. If the luminaire has been in use, allow it to cool for at least 20 minutes.
2. If necessary, remove the rear cover plate as described in "3.1.4: Connections compartment access" on page 18
3. Check that the jumper leads are correctly connected to match the local AC power voltage and frequency (see "3.2.1: Configuring for local AC power" on page 19).

4. See Figure 8. Ensure that there is a rubber seal **B** on the locking nut end of the cable gland **C**, and push this end through the hole provided in the housing so that the seal faces the outer surface of the housing.

5. Screw the locking nut **A** onto the cable entry from inside the housing. Prevent the cable entry from turning, and tighten the locking nut until the seal makes a water-resistant seal against the outer surface of the housing. Do not over-tighten, as this may damage the seal or housing.

6. Thread the cable through the compression nut **F**, gland **E**, washer **D**, and cable entry **C** into the housing.

7. Allow enough cable slack inside the housing to make connections. Prevent the cable entry from turning and tighten the compression nut sufficiently to make a water-resistant seal. Do not over-tighten, as this may damage the gland. Check that the cable is firmly gripped in the rubber gland.

8. See Figure 9. The power terminals block has three terminals labelled **Ground**, **Neutral**, **Live 1** and **Live 2**. Connect the power cable as follows:

- Connect the power cable's ground (earth) wire to the terminal marked **Ground**.
- If using a single-phase system, connect the power cable's neutral wire to the terminal marked **Neutral** and connect the power cable's live wire to the terminal marked **Live 1**.
- If using two 120 V phases of a three-phase system to obtain 208 V, connect one phase to **Live 1** and the next phase to **Live 2**.

Some common wire color codes are listed in Table 2:

Wire (EU)	Wire (US)	Pin	Marking	Screw (US)
brown	black	live	"L"	yellow or brass
blue	white	neutral	"N"	silver
yellow/green	green	ground		green

Table 2: Common wire color codes

9. If you are also connecting data cables, connect these now, referring to the next section in this manual. Otherwise replace the rear cover plate as described in "3.1.4: Connections compartment access" on page 18.

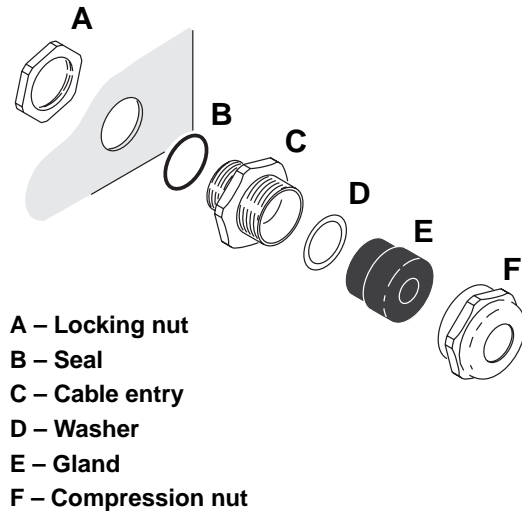

Figure 8: Cable gland assembly

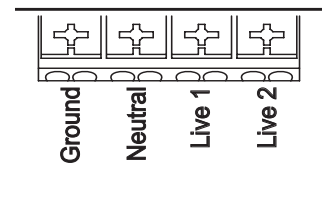

Figure 9: Power terminals

3.3 Installing a data link

Exterior 1200 Wash luminaires must be connected via a serial data link for DMX controller operation and for synchronized stand-alone operation of multiple luminaires. The data link is used to transmit DMX commands or synchronization data.

See Figure 5 on page 17 for a schematic diagram of cable layout.

3.3.1 *Planning the data link*

The following considerations must be taken into account when planning the data link:

- RS-485 data cable designed for exterior use is required. RS-485 cable has low capacitance and a characteristic impedance of 85 to 150 Ohms. It is electrically shielded and has at least 1 twisted pair of conductors. The minimum recommended wire size is 0.25 mm² (24 AWG) for runs up to 300 meters (1000 ft.) and 0.32 mm² (22 AWG) for runs up to 500 meters (1640 ft.).
- The maximum permitted control data cable length before a control signal amplifier is required is 500 meters (1640 ft.).
- Luminaires must be 'daisy-chained', i.e. the data cable must be connected in one single chain of luminaires.
- Each daisy-chained link may connect a maximum of 32 fixtures.
- An optically isolated amplifier-splitter such as the Martin RS-485 Opto-Splitter (P/N 90758060) must be used to:
 - extend a link beyond 500 meters (1640 ft.)
 - extend the link to include a further maximum 32 luminaires, or
 - branch the link into further single chains, each containing 32 luminaires. The Martin Opto-Splitter allows a link to be branched into four new chains.
- The last device on each chain must be terminated inside the luminaire using a 120 Ohm, 0.25 Watt resistor (available from your Martin Architectural supplier: P/N 04150308) connected across the hot and cold data terminals.
- Long parallel runs of AC power and control data cables may cause interference on the data link and must be avoided. Even if not required by law, separate conduits are recommended for power and data cables.
- One DMX universe has 512 DMX control channels available. In an installation containing multiple luminaires that each use 8 DMX channels, for example, one DMX universe will be required for every 64 luminaires ($512 \div 8 = 64$).

3.3.2 *Building the data link*

Data cable must enter and exit the luminaire through M16 x 1.5 cable glands that accept 5.5 - 10 mm (0.22 - 0.39 in.) diameter cables. Two glands are supplied with the luminaire. The glands must be replaced if the data cable external diameter is not within this range (see "8.4.2: Cable glands" on page 59).

One of two cable entry points can be used: either on the cover plate at the rear of the luminaire, or through the bottom of the connections/power compartment. Using the bottom of the connections/power compartment is recommended, as cables installed here will not be disturbed or flexed when the rear cover plate is removed for service. All cable entry/exit holes that are not used must be sealed with blanking plugs.

Connection pinouts

XLR connection

XLR connectors are suitable if DMX cable is used for the data link.

XLR pin numbers are normally marked on connectors. Connectors must be wired using the standard XLR DMX pin-out:

- Pin 1: Cable shield
- Pin 2: DMX Data 1 - (cold)
- Pin 3: DMX Data 1 + (hot)

Pins 4 and 5 on 5-pin XLR connectors are available for Data 2 connections in DMX 512-A or similar systems. They must be wired as follows:

- Pin 4: DMX Data 2 - (cold)
- Pin 5: DMX Data 2 + (hot)

To avoid ground/earth loop interference, ensure that the DMX cable shield does not come into contact with the shell or body of XLR connectors.

RJ-45 connection

RJ-45 connectors are suitable if CAT 5 cable is used for the data link.

RJ-45 cable connector pins are numbered from the left looking at the face of the connector with the locking clip on top (see Figure 10). Connectors must be wired using the standard RJ-45 DMX pin-out:

- Pin 1 (WHITE/orange): DMX hot (+)
- Pin 2 (ORANGE/white): DMX cold (-)
- Pins 7 (WHITE/brown) and 8 (BROWN/white):
Common

Pins 3 and 6 are available for Data 2 connections in DMX 512-A or similar systems. They must be wired as follows:

- Pin 3 (WHITE/green): Available for Data 2 hot (+)
- Pin 6 (GREEN/white): Available for Data 2 cold (-)

Pins 4 and 5 are not used in currently available lighting control systems but can be wired as follows:

- Pin 4 (BLUE/white): Not used
- Pin 5 (WHITE/blue): Not used

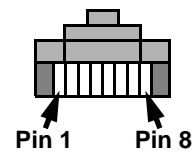

Figure 10: RJ-45 cable connector pins

Connecting the link

To build a data link:

1. If the luminaire has been in use, allow it to cool for at least 20 minutes.
2. Connect the data cable to a DMX output socket on the DMX controller and route it to the first luminaire on the link.
3. If the rear cover plate is not already open, remove it as described in "3.1.4: *Connections compartment access*" on page 18
4. Pass the data cable into the luminaire using one of the supplied cable glands to ensure waterproof cable entry. See page 21 for details of installing the cable gland.

- Data cable can be connected either via screw terminals on removable connectors or via RJ-45 connectors.

See Figure 11. Either connect the data cable to the luminaire's **Data 1 DMX IN** screw terminals (**A**) as follows:

- Connect shield to the terminal marked \downarrow
- Connect cold (-) to the terminal marked -
- Connect hot (+) to the terminal marked +

or install an RJ-45 connector on the data cable respecting the pinout listed under "*RJ-45 connection*" on page 23 and insert the connector into the **DMX IN RJ-45** socket (**B**).

- Depending on whether the luminaire is the last one on the link or whether the data link needs to be continued to another luminaire, follow one of the following two procedures:

- If the luminaire is the last one on a branch of the data link, use a pair of long-nosed pliers to move the DMX termination jumpers from the **Data set 1** pins (**C**) marked **OFF** to the pins marked **ON**. This places a resistance across data hot and cold to terminate the data link. Ensure that the termination resistance matches the type of cable used by setting the **Cable impedance** jumpers (**D**) to either 100Ω if using CAT5 cable for the data link, or 120Ω if using standard DMX cable.
- If you need to continue the data link to another luminaire, leave the termination jumpers at **OFF**. Pass the data output cable into the luminaire using another cable gland as described above. Connect to the luminaire's **Data 1 DMX OUT** terminals (**E**) or RJ-45 **DMX OUT** socket (**F**), respecting the same pinouts as for the data input cable.

- If using shielded CAT5 cable, connect the cable shield to PCB ground (earth) by routing the cable under the clamp (**G**), folding back the cable shield and tightening the clamp so that it makes good contact with the shield.
- If the power cable has not already been connected, you can connect it now (see "*3.2.2: Connecting to AC power*" on page 20). Otherwise reinstall the rear cover plate as described in "*3.1.4: Connections compartment access*" on page 18.
- Route the data output cable to the data input of the next luminaire, and continue connecting up to a total of 32 luminaires, output to input, as described above.

Add an optically isolated amplifier/splitter into the link if you intend to add more than 32 luminaires or branch the link.

The Data 2 connections are reserved for future use.

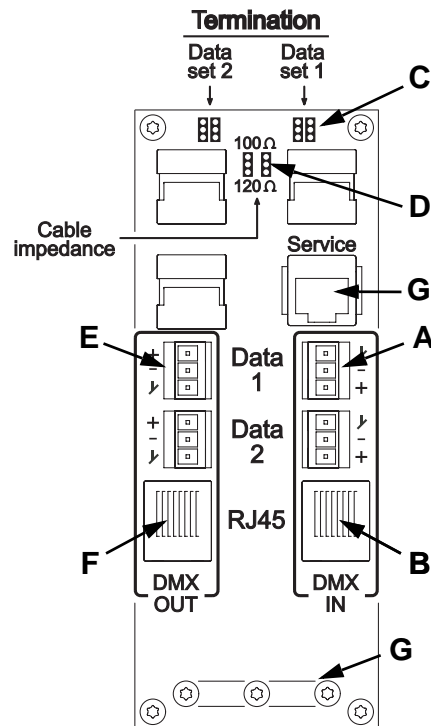

Figure 11: DMX connections

Section 4. General

4.1 General



DANGER! Read "Safety information" on page 4 before applying power to the Exterior 1200 Wash.

This section contains general information about the features and functions as well as basic programming and operating principles of the Exterior 1200 Wash. Read this section to familiarize yourself with the luminaire before attempting to program or operate it.

Important! Leave the luminaire powered on permanently except during service.

4.1.1 *Powering on*

When the luminaire is connected to power for the first time, it will start running a factory-set light show to test the fixture. It will continue to run this test show until a new show is programmed into it, or until it receives DMX commands.

When the luminaire is powered on in normal use, the luminaire software version appears in its display, runs an internal test and resets all effects to start positions. It must complete this reset before it can respond to DMX commands or run a stand-alone show.

4.1.2 *Maintaining power and temperature regulation*

Except during service, maintain power to the luminaire permanently even when the lamp is not lit.

In hot environments, this will allow the cooling system to regulate the luminaire's internal temperature at all times. Heat damage resulting from failure to maintain power is not covered by the product warranty.

In cold environments, the internal heat generated will keep electronics warm and ensure satisfactory performance at ambient temperatures as low as -20° C (-4° F). Note that if the temperature inside the luminaire falls below -10° C (14° F), the zoom effect is disabled until the internal temperature rises above this level again.

4.1.3 *Powering off*

Important! Switch off the lamp 8 minutes before you cut power to the luminaire.

If the lamp is lit and you wish to cut power (for service, for example), you must first switch off the lamp via DMX or the onboard control panel and wait at least 8 minutes before you cut power. This will give cooling fans enough time to reduce the luminaire's temperature and avoid heat damage. Damage caused by failure to follow this procedure is not covered by the product warranty.

4.1.4 Lamp operation

After being switched off, the lamp must cool for at least 8 minutes before it can be switched back on. "Lamp On" commands sent within 8 minutes of a "Lamp Off" command are stored and then attempted again after the time has elapsed.

The lamp can be set to start automatically as soon as power is applied to the luminaire or started via DMX.

Discharge lamps draw an extra inrush current for a fraction of a second during startup. If a large number of luminaires start up at the same time, this current can trip circuit breakers. Therefore:

- If the lamp is set to start automatically when power is applied, it starts after a random delay of 0 - 90 seconds.
- When controlling a large number of luminaires via DMX, switch on lamps one by one at intervals of about half a second.

To obtain optimum lamp life:

- Always allow the lamp to warm up fully for 5 minutes before turning it off.
- Switch off the lamp whenever illumination is not required for extended periods of an hour or more. Note that luminaire power should remain on at all times except during service.

4.1.5 'Exercise Program' at lamp off

To ensure free and correct effect movement even if some effects are not used for long periods, the Exterior 1200 Wash runs an 'exercise program' and checks effect movement every time the lamp is switched off.

In this program, the effect wheels run for approximately 20 seconds and the zoom effect runs to the full out (narrow) position. Effect wheels then position themselves with magnets at respective Hall sensors, and the zoom car moves to the zoom switch but does not activate it. The luminaire then checks that Hall sensors are activated and the zoom switch is open.

If an error occurs during checking, the luminaire resets. If the 'exercise program' is complete successfully, the luminaire waits with the cooling system active until either it receives a command or power is shut down.

4.1.6 Onboard control panel

The Exterior 1200 Wash features an onboard control panel and text-based LCD display.

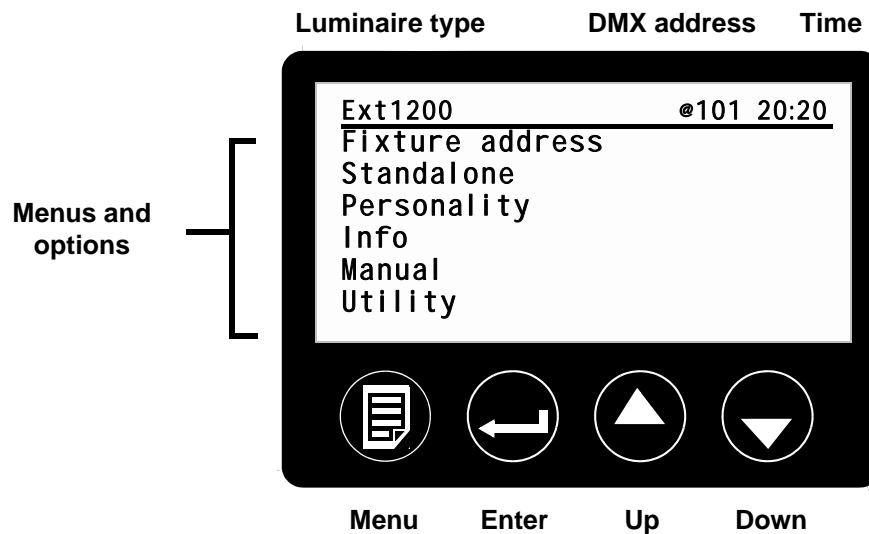

Figure 12: Control panel and LCD display

The onboard display and control panel allows the user to:

- obtain feedback about the luminaire – this is especially useful for service and maintenance purposes
- configure the luminaire's basic personality settings
- set up stand-alone operation
- set up the luminaire's DMX address so that commands can be sent to a specific luminaire from a DMX controller

Display

When the luminaire is powered on, the control panel displays information about the luminaire in two lists that it switches between approximately every 5 seconds:

- The **Fixture status** list displays information about luminaire temperature and fan speed in RPM (revolutions per minute)
- The **Lamp status** list displays a list of resettable counters that indicate hours of lamp use, number of times the lamp has been struck (powered on) and number of times the luminaire has been powered on.

Control panel

The display and control buttons are protected by a clear cover that is secured with Allen screws. Remove the cover for access to the control buttons and replace it when access is no longer required.

Use the control panel buttons as follows:

- Use the **Menu** button to open the menus or to navigate one level higher up in the menu structure.
- Use the **Enter** button to open a sub-menu, confirm a command or set a value.
- Use the **Up** and **Down** buttons to move up and down a list, toggle between options or increase and decrease a value.

By default, the display backlight goes out automatically 2 minutes after the lamp is turned on. The backlight returns to its preset intensity level as soon as a control button is pressed, or in the event of an error or warning message.

A backlight can be switched on, making the display easy to read in the dark, via the **Set backlight level** command in the **Personality** menu. The brightness of the display can be adjusted from 100 (maximum) to zero (off).

See "9.3: Onboard control panel menus" on page 74 for a complete overview of the options available in the onboard control panel.

Self-diagnostic feedback messages

In the event of a problem, the Exterior 1200 Wash will show a message in the display indicating the type of problem that has occurred.

4.1.7 Cooling fans

When power is applied, cooling fans run at full speed for a few seconds to clear any dust that has accumulated in the heat exchanger. After this, fan speed is regulated thermostatically to maintain an even temperature in the luminaire. When the lamp is switched off without cutting power to the luminaire, fans remain active.

4.1.8 LEDs and operating status

Two LEDs on the rear panel indicate the Exterior 1200 Wash's operational status. The LEDs are visible from a distance.

Normal operation is indicated when LED 1 lights green. LED 2 lights green when a valid DMX signal is being received. See Table 5 on page 73 for other status messages.

The LEDs flash off for a brief instant at regular intervals to prevent false readings when the light sensor samples the light level.

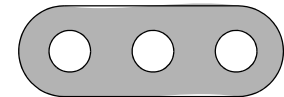

LED 1 LED 2 SENSOR

Section 5. Settings and configuration

5.1 Luminaire settings

This section describes how to set up luminaires for either:

- single fixture stand-alone operation, in which individual luminaires run programmed light shows independently,
- synchronized stand-alone operation, in which one master luminaire sends signals to client luminaires on a data link so that light shows are synchronized, or
- DMX operation, in which luminaires on a data link are controlled remotely using a DMX control device.

There are three ways to set up luminaires:

MUM (Multi-Utility Manager)	<p>The Martin MUM (Multi-Utility Manager) is a PC software application available from Martin Architectural in a set (P/N 90758090) that also includes a DABS1 interface adaptor and suitable cables. The set allows a PC to be connected to a luminaire via a data link or RJ-45 service socket.</p> <p>We recommend MUM because it provides an intuitive, easy-to-use, graphical user interface.</p> <p>Note that MUM can only be connected to, and set up, one luminaire at a time.</p> <p>Setup using MUM is described in "5.1.1: <i>Setting up a luminaire with a PC and MUM</i>" on page 33.</p>
Martin MP-2 Uploader	<p>The Martin MP-2 Uploader can be loaded with the luminaire's software, available from the Martin Architectural website, and then connected to the luminaire.</p> <p>When working with multiple luminaires, the MP-2 allows you to apply the same settings to all the luminaires on a data link.</p> <p>The MP-2 has a text-based interface and the luminaires do not provide feedback to the uploader. Therefore, the current settings of the luminaire can only be "read" by observing the behavior of the luminaire.</p> <p>Using the MP-2 is described in "5.1.2: <i>Setting up a luminaire with an MP-2</i>" on page 36.</p>
Onboard control panel	<p>The onboard control panel is a convenient way of configuring a luminaire with no external equipment, but access to the luminaire is required.</p> <p>Setup using the control panel is described in "5.1.3: <i>Setting up a luminaire with the onboard control panel</i>" on page 37.</p>

5.1.1 *Setting up a luminaire with a PC and MUM*

Using MUM, you can connect to and set up one luminaire at a time. Refer to the MUM user manual for instructions on installing and starting the MUM application.

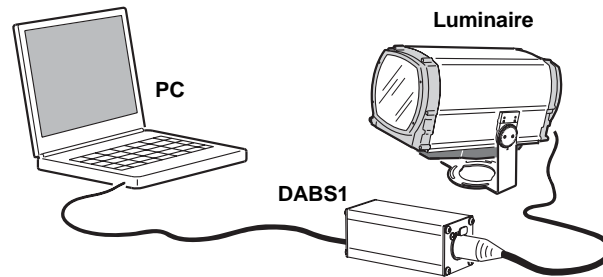

Figure 13: Connecting to a PC with MUM

Connecting a PC with MUM

To connect a PC with MUM to an Exterior 1200 Wash:

1. Obtain the MUM application, a DABS1 adaptor and interface cables. These are available as a set from Martin Architectural, P/N 90758090.
2. Connect the DABS1 adaptor to your PC using the USB cable.
3. Connect the DABS1 adaptor to the Exterior 1200 Wash using either an XLR connector connected to the data link or the RJ-45 service socket in the connections compartment behind the rear cover plate (see **G** in Figure 11 on page 24). If connecting via the data link, note that you may only connect to one luminaire at a time.
4. Apply power to the Exterior 1200 Wash and start the MUM application. The application will automatically detect an Exterior 1200 Wash if it is powered on and correctly connected. It will also retrieve information and current settings from the luminaire and display them.

Configuring a luminaire with MUM

Clock

The Exterior 1200 Wash has a battery-operated 24-hour clock that is used to start and stop stand-alone operation.

To set the clock:

1. Click on the **Fixture Info** button in MUM.

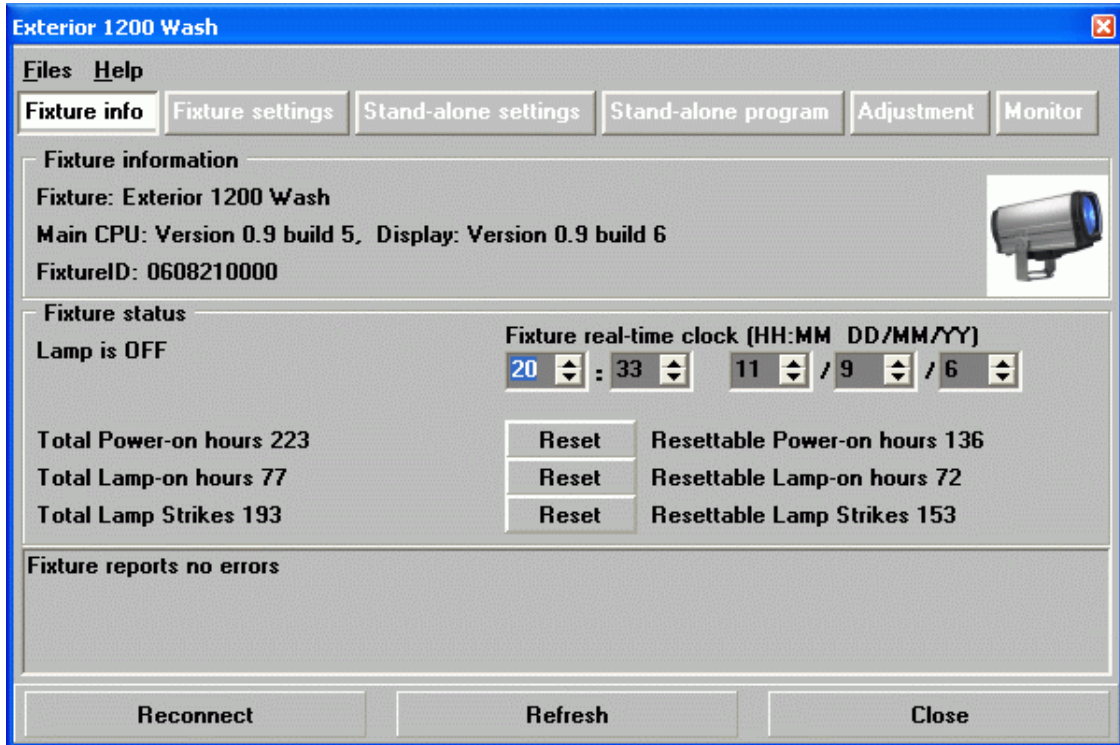

2. Using the **Fixture real-time clock** spin buttons, set the luminaire to the current time (expressed in the 24-hour clock in hours and minutes) and date. The time will be updated in the luminaire in real time.

Luminaire settings

To access the luminaire settings using MUM, click on the **Fixture settings** button.

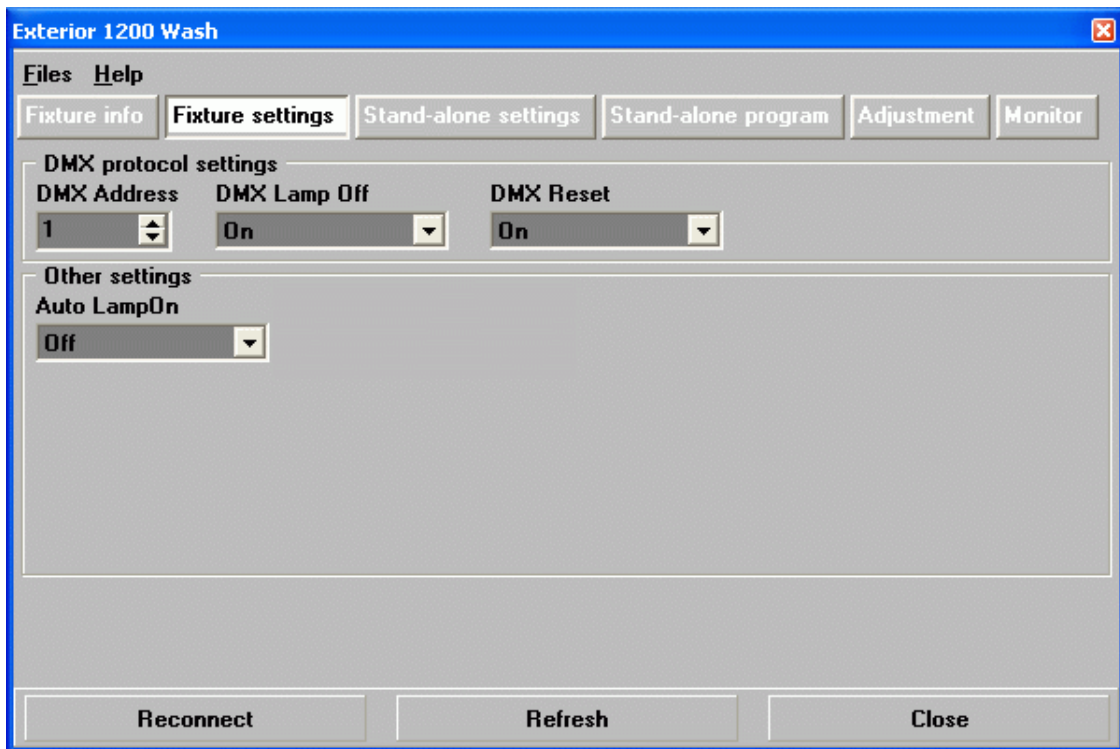

DMX address, DMX Lamp Off and DMX Reset settings

If you intend to operate the Exterior 1200 Wash with a DMX controller, the DMX address must be set on all luminaires for which individual control is required. If you are not familiar with the principles of DMX addressing in an installation with multiple fixtures, see "7.1.1: Setting DMX addresses" on page 50.

It is also a good idea to set the **DMX Lamp Off** and **DMX Reset** options. These settings are described in "7.1: Preparing for DMX control" on page 50.

The other default luminaire settings listed below are suitable for most applications, and it may not be necessary to change them.

Automatic lamp on

When the **Automatic Lamp On** personality is **On**, the luminaire turns on the lamp within 90 seconds of power on. When set to **Off** (the default setting), a lamp-on command is required to turn on the lamp.

5.1.2 Setting up a luminaire with an MP-2

The Martin MP-2 Uploader can be connected to one or more luminaires. If multiple luminaires are connected together to an MP-2, the settings applied will be sent to all the luminaires.

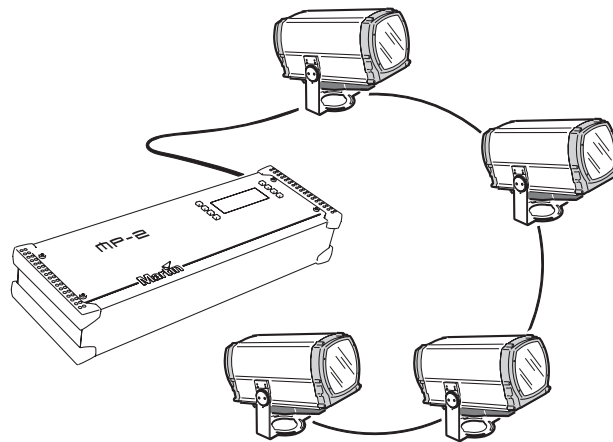

Figure 14: Connecting to an MP-2 Uploader

Connecting an MP-2

To connect an MP-2 Uploader to an Exterior 1200 Wash:

1. Obtain an MP-2 (available from Martin Architectural, P/N 90758420) with a flash memory card, and the Martin Uploader program (available free of charge from the Martin website). Download the Exterior 1200 Wash luminaire software from the Martin website as described in the Martin Uploader help file and MP-2 user manual.
2. Connect the MP-2 to the Exterior 1200 Wash using either an XLR connector connected to the data link or the RJ-45 service socket in the connections compartment behind the rear cover plate.
3. Apply power to the Exterior 1200 Wash and MP-2.

Configuring the Exterior 1200 Wash with the MP-2

See "9.4: MP-2 control menus" on page 75 for a complete overview of the control menus available for the Exterior 1200 Wash in the MP-2 Uploader.

DMX address

If you intend to use a DMX controller, you need to set the luminaire's DMX address. If you want a group of luminaires to respond identically and do not need individual control, connect the MP-2 to all the luminaires in that group. The DMX address you set will be given to all the luminaires.

If you are not familiar with the principles of DMX addressing in an installation with multiple fixtures, see "7.1.1: Setting DMX addresses" on page 50.

To set the DMX address, scroll through the MP-2 menus and select **Fixture address**. Enter a value between 1 and 505 (512 DMX channels are available in one DMX universe, and the Exterior 1200 Wash uses 8 channels).

Clock

The Exterior 1200 Wash has a battery-operated 24-hour clock that is used to start and stop stand-alone operation.

To set the clock:

1. Scroll through the MP-2 menus and select **Adjust** → **Real time clock**.
2. Set the luminaire to the current time (expressed in the 24-hour clock in hours and minutes) by scrolling through and entering values for **Hour** and **Minute**.

Luminaire settings

Luminaire settings are accessed under **Personality** in the MP-2 menus.

DMX Lamp Off and DMX Reset settings

If DMX will be used to control the luminaire, it is a good idea to set the DMX Lamp Off and DMX Reset options via **Personality** → **DMX lamp off** and **Personality** → **DMX reset**. These settings are described in "7.1: Preparing for DMX control" on page 50.

The other default luminaire settings listed below are suitable for most applications, and it may not be necessary to change them.

Automatic lamp on

When **Personality** → **Auto lamp on** is set to **On**, the luminaire turns on the lamp within 90 seconds of power on. When set to **Off** (the default setting), a lamp-on command from the DMX controller is required to turn on the lamp.

5.1.3 Setting up a luminaire with the onboard control panel

DMX address

If you intend to use a DMX controller, you need to set the luminaire's DMX address. If you are not familiar with the principles of DMX addressing in an installation with multiple fixtures, see "7.1.1: Setting DMX addresses" on page 50.

To set the DMX address:

1. Press the **Menu** button to enter the main menu and use the **Up** and **Down** buttons if necessary to select **Fixture address**.
2. Press **Enter**.
3. Use **Up** and **Down** to enter a value between 1 and 505 (512 DMX channels are available in one DMX universe, and the Exterior 1200 Wash uses 8 channels). Pressing **Up** and **Down** simultaneously sets the DMX address to 1.
4. Press **Enter** to confirm your choice and return to main menu. If you press **Menu**, you will return to the main menu without saving the address you entered.

Clock

The Exterior 1200 Wash has a battery-operated 24-hour clock that is used to start and stop stand-alone operation.

To set the clock:

1. If the display is showing **Fixture status** and **Lamp status**, press **Menu** to enter the main menu. Scroll down to **Personality**, and press **Enter**.

2. In the **Personality** menu, scroll down to **Set clock**.
3. Set the luminaire to the current time (expressed in the 24-hour clock in hours and minutes) by entering values for **Hour** and **Minute**. Use the **Up** and **Down** buttons to scroll values and **Enter** to confirm.

Luminaire settings

Luminaire settings are accessed in the **Personality** menu.

DMX Lamp Off and DMX Reset settings

If DMX will be used to control the luminaire, it is a good idea to set the DMX Lamp Off and DMX Reset options via **Personality** → **DMX Lamp Off** and **Personality** → **DMX Reset**. These settings are described in "7.1: Preparing for DMX control" on page 50.

Automatic lamp on

When **Personality** → **Auto Lamp On** is set to **On**, the luminaire turns on the lamp within 90 seconds of power on. Use this setting if you intend to run stand-alone shows. When set to **Off** (the default setting), a lamp-on command from the DMX controller is required to turn on the lamp.

Section 6: Stand-alone operation

6.1 Stand-alone programming: general



DANGER! Read "*Safety information*" on page 4 before programming or operating the Exterior 1200 Wash.

6.1.1 Introduction

Stand-alone operation is a mode where the luminaire executes color changes at set intervals and speeds, at pre-defined periods during the day, and/or when the light level falls below a defined level. The term *stand-alone* is used to mean that the Exterior 1200 Wash is not connected to a control device, but is pre-programmed with a series of up to 20 scenes that play continuously in a loop.

An Exterior 1200 Wash can run a stand-alone show independently or with synchronized scene changes with other Exterior 1200 Wash luminaires and most other Martin Architectural luminaires (see "6.1.2: *Synchronized operation with multiple luminaires*" on page 40 for details).

About scenes

A stand-alone light show consists of scenes. Each scene is a particular lighting effect with predetermined color, intensity and duration. Up to 20 scenes can be programmed into the Exterior 1200 Wash's program memory.

Each scene has a dynamic part – the fade – during which effects move to the scene's programmed positions, and a static part – the wait – where effects do not change.

The duration of the fade and wait is programmed individually for each scene. The fade time may be 0 - 120 seconds; the wait time may be 1 second to 12 hours. The total time it takes a scene to execute is the sum of the fade and wait times.

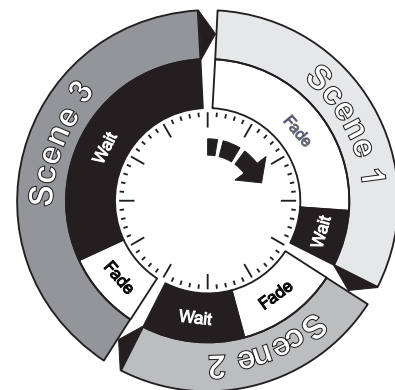

Figure 15: Scene timing

6.1.2 Synchronized operation with multiple luminaires

If you are running multiple luminaires on a data link, you can synchronize action so that all luminaires start their programmed shows and start fading to the next scene at the same time.

An Exterior 1200 Wash running a stand-alone show can perform synchronized scene changes with other Exterior 1200 Wash luminaires as well as Martin Architectural luminaires of the following types:

- Exterior 200

- Exterior 600
- Exterior 600 Compact
- Inground 200 CMY
- FiberSource CMY150
- Imager series
- Alien 02 series
- MiniMAC Maestro

In synchronized operation, one luminaire is set as the master and the others are set as clients. Each luminaire must be programmed with its own show. When the master fades to the next scene or starts its show from the beginning again, it tells each client luminaire to fade to its next scene or start its show again. In other words, each client luminaire will run its show repeatedly in a cycle, changing scene when prompted to by the master, until the master finishes its own show and signals that all luminaires should start from the first scene once again.

If you want to keep things as simple as possible when programming synchronized operation, ensure that:

1. Every luminaire has the same number of scenes.
2. Scene times are a few seconds longer on the master luminaire than on client luminaires (this will ensure that client luminaires always have time to finish scenes before the master tells them to start the next scene).

It is important to note that the only commands transmitted by the master are scene change and show start commands. No data about the *appearance* of the scene is transmitted between luminaires.

For a more detailed explanation of synchronized operation and how advanced effects can be created by programming luminaires with a different number of scenes, see the next section.

Synchronized stand-alone operation: detailed description

Note: This section gives advanced information about stand-alone synchronized operation. You only need to read it if you require help with problem diagnosis or if you want to program advanced synchronized light shows.

The principles in stand-alone synchronized operation are as follows:

1. A scene contains a fade section, followed by a wait section
2. Each luminaire can be individually programmed with up to 20 scenes, and each scene can have its own individual fade and wait times.
3. Scenes are numbered from 0 to 19.
4. In synchronized operation, one master luminaire issues commands to the other client luminaires to "go to scene xx", where xx is the scene number that the master will execute next.
5. If a client has fewer scenes than the master, it will derive which scene to go to by dividing the number of the scene it has been commanded to go to (scene 5, for example) by the total number of scenes that the client luminaire has (4, for example) in whole numbers (no decimal places). In this example 5 divided by 4 results in 1, with 1 remainder. This remainder will be the number of the scene that the client luminaire starts - scene 1. Generally though, when a client luminaire reaches its own last scene before the Master luminaire, a "go to scene xx" message will result in the first scene being played.

6. If a client has more scenes than the master calls, the last scenes in the client will never be executed, as is the case with scene S4 in the following example.

F=fade, W=wait Timeline =>

	M0	M1	M2	M3	
Programmed in Master	F W	F W	F W	F W	
	S0	S1	S2	S3	S4
Programmed in Client	F W	F W	F W	F W	F W
Result	M0	M1	M2	M3	
	F W	F W	F W	F W	
	S0	S1	S2	S3	
	F W	F W	F W	-- --	F W

7. In synchronized operation, the wait time is determined by the master. Every client luminaire fades and waits at its own rate and then remains in the “wait” state until it receives a “start scene xx” command from the master.
8. A client luminaire will not listen for the next message from the master luminaire before it has finished its current scene. This may result in a client skipping a scene if the client has a longer scene time than the master. Note that in the following example, the scenes in the client run out of their programmed sequence because scenes 0 and 2 on the client are longer than the corresponding scenes on the master.

M=master, S=client
F=fade, W=wait Time >

Programmed	M0	M1	M2		
Master	F W	F W	F W		
	S0		S1		S2
Client	F W	F W	F W		
Result	M0	M1	M2	M0	M1
Master	F W	F W	F W	F W	F W
	S0		S2		S1
Client	F W		F W	-- --	F W
				-- --	-- --

6.1.3 Stand-alone programming methods

The Exterior 1200 Wash provides three stand-alone programming methods; using:

1. the Martin MUM application on a personal computer (recommended because it provides an intuitive, easy-to-use, graphical user interface),
2. an MP-2 Upload device, or
3. the luminaire’s onboard control panel.

If you are programming a group of luminaires to perform the same scenes with synchronized triggering, we recommend that you either:

- Use an MP-2 Uploader to simultaneously program the same show on all luminaires connected to the data link, or
- Use MUM to program a show on one client luminaire, download and save this luminaire’s program and settings to your PC using MUM’s Files menu, and then upload the program and settings to each subsequent luminaire that you connect to.

6.2 Stand-alone programming with a PC and MUM



DANGER! Read "*Safety information*" on page 4 before programming or operating the Exterior 1200 Wash.

The programming of stand-alone shows and setting up of master/client operation is best performed from a personal computer using the Martin MUM (Multi-Utility Manager) application. The computer is connected to a luminaire via a DABS1 interface, used to program the stand-alone settings for that luminaire, and then removed. Once a luminaire is subsequently switched on, it can automatically run the scenes in its program in a loop, according to the triggering criteria you have specified (time of day, and/or light level).

If you are not familiar with the use of MUM, it is recommend that you familiarize yourself with it by reading the MUM Help files and MUM user manual.

6.2.1 *Connecting*

To establish a connection:

1. Connect a DABS1 adaptor to a PC and to the Exterior 1200 Wash.
2. Power on the Exterior 1200 Wash and start the MUM application. The application will automatically detect an Exterior 1200 Wash if it is powered on and correctly connected. It will also retrieve the luminaire's current settings and display them.

6.2.2 Stand-alone settings

First, the luminaire needs to be configured to know if and when to activate a stand-alone program:

Click **Stand-alone settings** to display the window below.

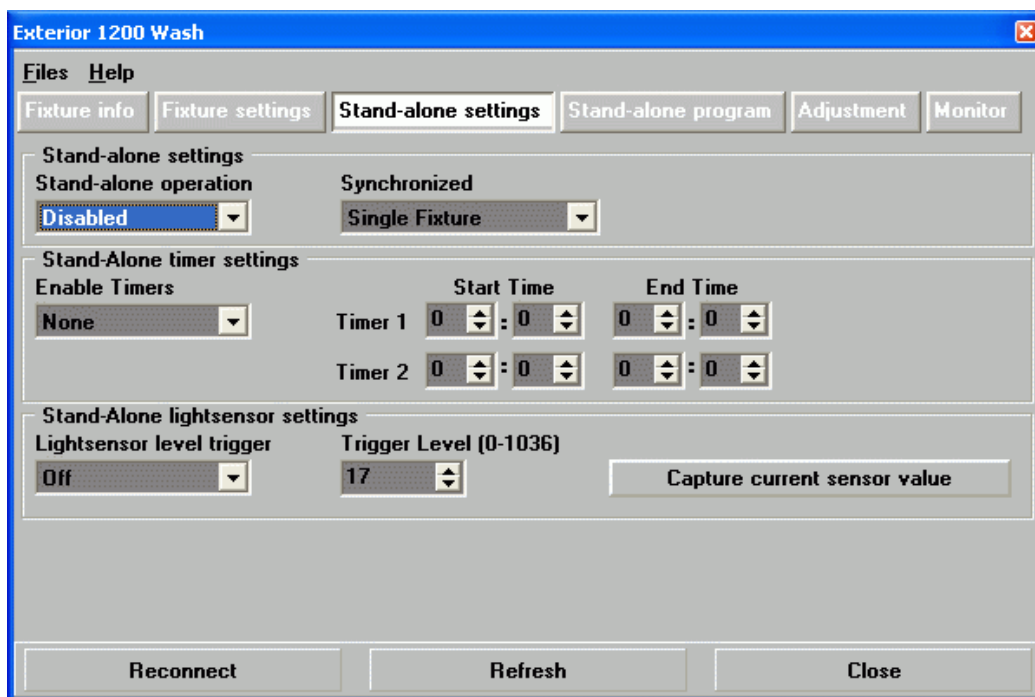

The following options are available:

Stand-alone operation	Activates or deactivates stand-alone operation. If enabled, stand-alone operation will start automatically when the luminaire is powered on, or the luminaire is being controlled by DMX and the DMX control signal disappears.
Synchronized	Sets the luminaire to one of the following modes: Single Fixture: operates in stand-alone mode independently of other luminaires Master: sends trigger signals to other luminaires, or Synchronized: client – receives trigger signals from other luminaires. <i>No more than one luminaire may be the master. Any luminaire on the link, regardless of its position, may be the master. All other luminaires must be set as clients.</i>
Stand-alone timer settings	See "Setting a timer trigger" on page 45.
Stand-alone light sensor settings	See "Setting a light-level trigger" on page 45.

Automatically triggering stand-alone operation

Stand-alone operation can be set to a timer trigger that activates operation for one or two periods in a 24 hour period, or set to a light-level trigger that uses a light sensor to activate operation when ambient light is below a certain level.

If both the timer *and* the light-level trigger are used, operation starts whenever it is darker than the light-level setting, and within the times set.

Setting a timer trigger

To set a timer trigger:

1. Make sure the correct time has been set on the luminaire's built-in clock (see "Clock" on page 34).
2. Select **None**, **Timer 1**, **Timer 2** or **Both Timers** in the **Enable Timers** box.
3. Use the **Start Time** and **End Time** spin buttons to set a period of stand-alone operation on the selected timer(s).

Setting a light-level trigger

To set a light-level trigger:

1. Set **Light level sensor trigger** to **On**.
2. Set the light level that triggers stand-alone operation using the **Trigger level** spin button, or press **Capture current sensor value** to set the current ambient light level to trigger stand-alone operation.

To avoid false triggering by sudden light changes caused by vehicle headlights or clouds, for example), the light level must remain above or below the trigger threshold for 5 minutes to activate the trigger.

6.2.3 Programming effects in scenes

The programming of effects is performed using the **Stand-Alone program** controls:

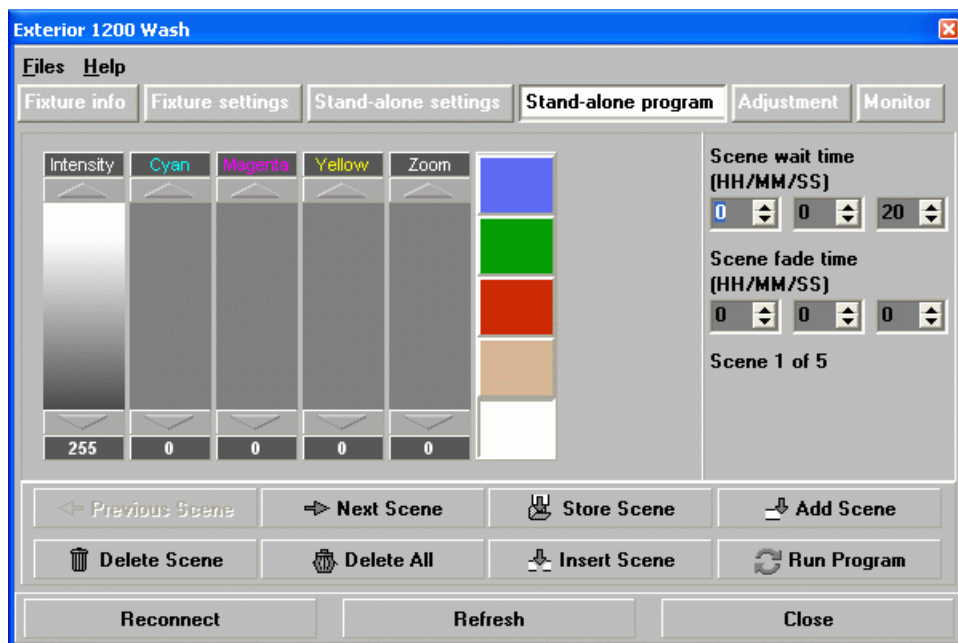

The following options are available:

Intensity	The dimmer provides smooth, high-resolution 0 - 100% dimming.
Cyan Magenta Yellow	The CMY color mixing system is based on graduated cyan, magenta, and yellow color filters. A full spectrum of colors can be achieved by varying the amount of each filter from 0 to 100%. Note that mixing 3 colors results in loss of light - the light is blacked out when all 3 colors are fully applied. For maximum brightness, mix only 2 colors at a time.
Zoom	The lens can be driven forwards or backwards to vary the size of the beam.
Filter color buttons	Clicking on the five square colored buttons selects positions on the color wheel. As standard, the color wheel has red, green, and blue dichroic color filters, a 5500 to 3400 K dichroic CTC filter and an open (white) position. It can be used alone or in combination with CMY color mixing.
Scene fade time	The fade time, anything from 0 to 120 seconds, is the time it takes to change from one effect to another.
Scene wait time	This is the duration a color is applied. A wait time can be from 1 second to 12 hours.

When setting scene fade and scene wait times for luminaires in synchronized operation, avoid unexpected problems by making sure that each scene time is slightly longer in the master luminaire than in the client luminaires (see "6.1.2: Synchronized operation with multiple luminaires" on page 40 for full details).

Scene management

Once you have specified a mix of effects, you can store the scene using the options available under the Program menu:

Store scene	Save settings in the current scene.
Add scene	Save settings in a new scene at the end of the current sequence of scenes.
Insert scene	Save settings in a new scene before the current scene. <i>Tip: Think of the Add and Insert commands as Save commands, to be used as the last step after programming all effects.</i>
Delete scene	Remove the current scene from memory. Scenes after the deleted scene are renumbered.
Next scene	Step to the next scene.
Previous scene	Step to the previous scene.
Delete all	Remove all scenes from the luminaire memory.
Run program	Run the scenes in the programmed light show.

When the program is run, scenes execute in a continuous, ascending loop.

Note that, if a "client" luminaire has:

- Fewer scenes than the master luminaire, it will run these in a cycle continuously, until the master luminaire signals that the program should start from the beginning again.

- More scenes than the master luminaire, then the additional scenes will never run, because the program will reset to the first scene when the master starts its program from the beginning.

6.2.4 Programming the same stand-alone show on multiple luminaires

Although you can only connect to and program a single luminaire at a time using the MUM application, you can use MUM to program a single luminaire, then use the commands in MUM's Files menu (see illustration below) to download and save the luminaire's settings to a file on your PC, and then upload the stand-alone program and luminaire settings to each subsequent luminaire that you connect to. This is useful if you have a group of luminaires of the same type that will run the same stand-alone show.

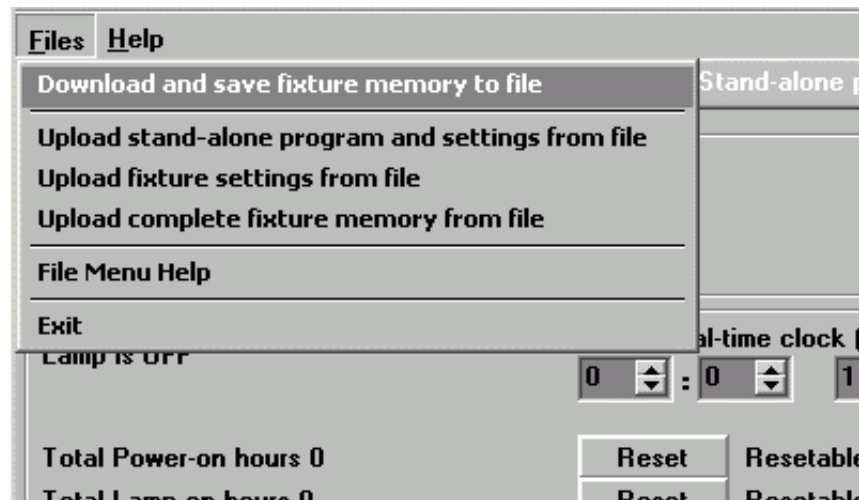

6.3 Stand-alone operation

6.3.1 *Starting show playback automatically at luminaire power-on*

Execution of the pre-programmed scenes in a loop will automatically resume when the luminaire is powered on if stand-alone operation and the automatic lamp-on function are enabled by one of the following three methods:

Using MUM:

- Stand-alone operation in the Stand-alone settings window
- Auto LampOn In the Fixture Settings window

Using an MP-2:

- Stand Alone → Enable SA
- Personality → Auto lamp on.

Using the onboard control panel:

- Standalone → Enable
- Personality → Automatic Lamp On.

6.3.2 *DMX controller override during stand-alone show playback*

If an Exterior 1200 Wash is connected to a DMX controller and receives DMX signals during show playback, the stand-alone show will stop running and the luminaire will respond to the DMX controller. DMX signals always have priority over the running of a stand-alone show.

Section 7. DMX control

7.1 Preparing for DMX control



DANGER! Read "Safety information" on page 4 before programming or operating the Exterior 1200 Wash.

To control a luminaire via DMX, it must be set up to respond to commands from the controller on specific DMX channels. This chapter describes how to set this up. It also describes DMX lamp off and DMX reset settings that you may wish to alter.

You can use a personal computer with the Martin MUM (Multi-Utility Manager) application running on a PC, a Martin MP-2 Uploader or a Martin DAD (DMX Addressing Device) to prepare your Exterior 1200 Wash. Of these options, MUM is the easiest to use because it has a graphical user interface.

Follow the instructions in "5.1: Luminaire settings" on page 32 to choose and connect a setting device, and then refer to this chapter for information about specific settings.

7.1.1 Setting DMX addresses

If individual control of each Exterior 1200 Wash is required, each luminaire must be set up to receive instructions from the DMX controller on a group of DMX channels that are not used by any other device in its DMX universe. The DMX address, also known as the control address or start channel, is the first of these channels. Each luminaire uses this channel and the channels immediately above it to receive instructions.

Exterior 1200 Wash Narrow, Medium, Wide and Very Wide models use eight DMX channels, i.e. the start channel plus the next seven channels. If the control address is set to 100, the luminaire uses channels 100, 101, 102, 103, 104, 105, 106, and 107. Channel 108 is available as the DMX address for the next luminaire.

If two or more luminaires are set up with the same address, they will receive the same instructions and behave identically. Setting up identical luminaires with the same address is a good tool for troubleshooting unexpected behavior and an easy way to achieve synchronized action.

DMX addressing with MUM

To set a DMX address using the MUM application, use the **DMX Address** spin button in the **Fixture Settings** window. The luminaire's DMX address is updated in real time. MUM can only set the DMX address on one luminaire at a time, and must be connected to one luminaire only via the data link or service port.

DMX addressing with an MP-2 Uploader

To set a DMX address using an MP-2 Uploader, scroll through the menus to **Fixture address** and enter the required value. The MP-2 can be connected to multiple luminaires via the data link, and will set the same address in all the luminaires it is connected to.

DMX addressing with the onboard control panel

To set a DMX address using the onboard control panel, enter the **Fixture address** menu and enter the required value.

DMX addressing with a DAD

To set a DMX address using a DAD, follow the instructions in the DAD user manual. The DAD can only set the DMX address on one luminaire at a time, and must be connected to one luminaire only via the data link.

7.1.2 DMX Lamp Off option

When the DMX Lamp Off feature is ON (the default setting), lamp power can be turned off from the controller by setting channel 1 to a DMX value from 248 to 255 (97-100%). When set to OFF, the Lamp Off command executes only if channels 3, 4, and 5 are set to values from 230 to 232. Bear in mind that if you turn a lamp off, you must allow it to cool for eight minutes before you can restrike it.

7.1.3 DMX Reset option

When the DMX Reset feature is ON (the default setting), the luminaire can be reset from the controller by setting channel 1 to a DMX value from 208 to 217 (81-85%). When DMX Reset is set to OFF, the reset command executes only if channels 3, 4, and 5 are set to values from 230 to 232.

7.2 DMX controller operation



DANGER! Read "Safety information" on page 4 before operating the Exterior 1200 Wash.

The Exterior 1200 Wash may be operated with any lighting controller that is compatible with the USITT DMX 512 (1990) or USITT DMX 512A standards.

See "3.3: Installing a data link" on page 22 for connection requirements and "9.5: DMX protocol" on page 77 for an overview of DMX control channels and values.

If an Exterior 1200 Wash is connected to a DMX controller and receives DMX signals during stand-alone show playback, the stand-alone show will stop running and the luminaire will respond to the DMX controller. DMX signals always have priority over the running of a stand-alone show.

7.2.1 Effect operation

The effects reset to their "home" position when the Exterior 1200 Wash is powered on. The Exterior 1200 Wash can also be reset from the DMX controller on channel 1. To limit the possibility of accidentally resetting the luminaire in the middle of a light show, you can set up the luminaire so that the reset command only works if the CMY channels are all set to a DMX value from 230 to 232 (see "7.1.3: DMX Reset option" on page 51).

7.2.2 Lamp

Lamp on

With the default setting, the lamp remains off until a "lamp on" command is sent from the controller. To have the lamp strike automatically, activate the Automatic Lamp On personality (see "5.1: Luminaire settings" on page 32).

A large peak of electric current is drawn for an instant when striking a discharge lamp. Striking many lamps at once may cause a voltage drop large enough to prevent lamps from striking and/or trip circuit breakers. When striking multiple lamps, program a sequence that strikes lamps one at a time at 5 second intervals. If Automatic Lamp On is enabled, there is a delay of up to 90 seconds after power is applied before the lamp strikes. This delay is determined by the luminaire's DMX address.

Lamp off

The lamp can be turned off from the controller by sending a "lamp off" command on channel 1. If the DMX Lamp Off personality is OFF (see "7.1.2: DMX Lamp Off option" on page 51), the command only works if each of the CMY channels (3, 4, and 5) is set to a DMX value from 230 to 232.

After being turned off, the lamp must cool for at least 8 minutes before it can be turned back on. "Lamp on" commands sent within 8 minutes of a "lamp off" command are stored and then executed after 8 minutes have elapsed.

7.2.3 Color

CMY color mixing

The CMY color mixing system is based on graduated cyan, magenta, and yellow color filters. A continuous range of mixed colors may be achieved by varying the amount of each filter from 0 to 100%. Note that mixing 3 colors results in a loss of light - the light is blacked out when all 3 colors are fully applied. For maximum brightness, mix only 2 colors at a time.

Color wheel

The color wheel has red, green, and blue dichroic color filters plus a 5500 K to 3400 K CTC (color temperature correction) filter and an open (no filter) position. The color wheel can be used independently of the CMY system or together with CMY color mixing to increase color saturation. The wheel scrolls in full steps.

7.2.4 Dimmer

The mechanical dimmer provides smooth, high-resolution 0 - 100% intensity control.

7.2.5 Zoom

On Narrow and Medium models, the beam angle can be varied remotely using a motorized zoom feature. Depending on the optical configuration of the luminaire, the one-tenth peak beam angle can be varied within the following limits:

- Exterior 1200 Wash Narrow, 14° - 31°
- Exterior 1200 Wash Medium, 20° - 50°

The zoom is disabled if the temperature inside the luminaire falls below -10° C (14° F) but is re-activated as soon as the internal temperature rises above this level.

7.2.6 Effects speed (*tracking and vector control*)

The speed at which effects fade, that is, move from one position to another, can be controlled in two ways known as tracking control and vector control:

- With *tracking* control, fades are programmed using the controller's fade time. The controller divides the fade into small elements that the luminaire "tracks." The Exterior 1200 Wash has a digital filter algorithm that averages several updates to ensure smooth movement.
- *Vector* control provides a way to program fades on controllers without programmable fade times or cross-faders. With vector control, instead of breaking up the movement into many small positions, the controller sends one position value and one speed value and the luminaire's own software controls the movement. Vector control may provide smoother fades than tracking control with some controllers, particularly when the controller is busy with a large number of processor-intensive operations, and particularly on very slow fades.

You can select tracking or vector control using your DMX controller, but you cannot use both at the same time.

Section 8. Service and accessories

8.1 Service: general



DANGER! Read "*Safety information*" on page 4 before servicing the Exterior 1200 Wash.

Important! The Exterior 1200 Wash requires regular service and maintenance to maintain reliable operation and protect the investment it represents.

Before servicing, switch off the lamp via DMX or the onboard control panel and allow the luminaire to cool with fans running for 20 minutes before powering off.

The service and maintenance procedures described in this section must be carried out by qualified professionals only. Any service procedures not described in this section must be carried out by Martin Global Service or its authorized agents.

Martin uses the best-quality materials and coatings available to ensure optimum performance and the longest possible component lifetimes. However, optical components in all luminaires are subject to wear and tear over the life of the fixture, resulting in gradual changes in color rendition of dichroic filters or the specular properties of reflectors, for example. The extent of wear and tear depends heavily on operating conditions, maintenance and environment, so it is impossible to specify precise lifetimes for optical components. However, you will eventually need to replace optical components if their characteristics are affected by wear and tear after an extended period of use and if you require luminaires to perform within very precise optical and color parameters.

8.2 Beam adjustment

The beam can be adjusted in a vertical plane (tilt) using the tilt lock on the yoke. The beam can be adjusted in a horizontal plane (pan or rotation) using the curved slots in the yoke base.

To adjust tilt:

1. Support the luminaire to ensure that it cannot tilt unexpectedly under its own weight. See Figure 16. Loosen the tilt lock screws on each side of the mounting yoke.
2. Tilt the luminaire to the desired angle in the yoke and retighten the screws to a torque of 16 Nm (11.8 ft.-lbs.).

To adjust pan:

1. Loosen the anchor bolts in the yoke base slightly so that the luminaire can be rotated.
2. Adjust the pan position and retighten the bolts.

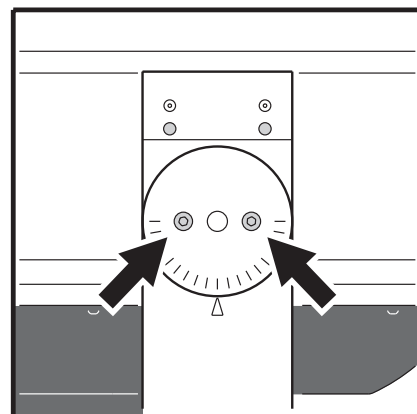

Figure 16: Tilt lock screws

8.3 Cleaning



DANGER! Do not use a high-pressure water jet for cleaning. Do not direct a high-pressure air jet at the cooling fan in the heat exchanger. Take care not to damage seals, wiring, the heat exchanger channels and the cooling fan during cleaning.

Important! Intermittent lamp cutouts are a sign of critical overheating with a risk of damage to the luminaire. If the lamp cuts out intermittently, turn off power to the luminaire immediately and follow the inspection and cleaning procedures described below.

Periodic cleaning, especially of the heat exchanger, is critical in order to maintain adequate cooling and satisfactory performance.

The intervals at which cleaning is required will vary depending on the amount of airborne dust and other particles around the installation. Therefore, the temperature readings in the display panel must be monitored and luminaires must be visually inspected for signs of dirt and dust build-up frequently over the first few months of use. Once a pattern has been established, a cleaning schedule can be drawn up.

If the heat exchanger becomes increasingly clogged with dirt and dust, the cooling fan will run at increasing speed and the temperature readings in the display (or visible when MUM is connected) will rise. If temperatures rise too high, the luminaire will show a warning in its display. Finally, if the temperature inside the luminaire exceeds a safe level, a thermostatic safety switch shuts down power to the lamp and reapplies power when the temperature has fallen to within safe limits.

If intermittent lamp cutouts occur, stop using the luminaire immediately, inspect it, and clean it if dirt and dust has built up in the heat exchanger. If the heat exchanger appears to be clean, contact Martin Architectural for assistance.

8.3.1 *Cleaning the heat exchanger*

The heat exchanger cooling fan, vents and channels must be kept clean to allow free airflow through the heat exchanger. Use compressed air at low pressure to clean the heat exchanger. Do not spray water or dirt at the fan motor.

To clean the heat exchanger:

1. Cut lamp power, allow the luminaire to cool with fans running for 20 minutes, then isolate the luminaire from AC power and lock out power.
2. Visually check the level of dirt and dust buildup through the heat exchanger vent at the front of the luminaire and the fan grille:
 - If the fan, vents and channels are perfectly clean, consider increasing intervals between cleaning.
 - If the fan, vents and channels have heavy dirt or dust deposits or are clogged, proceed to point 3. below and reduce intervals between cleaning.
3. Remove the heat exchanger cowling and cooling fan cowling retaining screws and lower the cowlings from the bottom of the luminaire for access to the heat exchanger channels.
4. Blow loose dirt out of the heat exchanger with low-pressure compressed air, used in combination with a soft brush if necessary. You can use a long, flat, thin object to

dislodge clogged dirt from the spaces between the aluminum channels, but apply gentle pressure only to avoid damage to the channels. Do not direct the jet of compressed air at the center of the cooling fan, as you may blow dust into the fan motor and bearing and cause premature failure of the fan.

5. Reinstall the cowlings and tighten retaining screws to 2 Nm (1.5 ft.-lbs.).

8.3.2 Cleaning the housing and front glass

The Exterior 1200 Wash's aluminum housing and front glass can be cleaned with mild detergents such as those for washing cars. To clean the housing and front glass:

1. Cut lamp power, allow the luminaire to cool with fans running for 20 minutes, then isolate the luminaire from AC power and lock out power.
2. Visually check that the silicone seals are in good condition. If any seal shows signs of damage or loss of water resistance, stop cleaning the luminaire and contact a Martin authorized service technician for seal replacement.
3. If seals are in good condition, rinse off loose dirt with a hosepipe or low-pressure water spray. Do not spray water into the heat exchanger.
4. Wash the aluminum housing and front glass using warm water with a little mild detergent and a soft brush or sponge. Do not use abrasive cleaners.
5. Rinse with clean water.

8.4 Seals and cable glands

The main housing has an IP rating of 65: it is protected against dust and can withstand low pressure water jets. To maintain protection against dust and water:

- Replace any seal that becomes brittle or shows visible signs of wear.
- Ensure that seals are flush with, or protrude slightly above, the surface of the aluminum housing and covers.
- Ensure that cable glands are tightened both to the housing or cover and the cable.
- Tighten all external cover and cover plate retaining screws to the torque settings specified in Table 3 on page 60. At this torque, seals will be compressed by about one-third and will be waterproof and dustproof to IP65.
- When replacing the front cover, cross-tighten screws gradually, working around in a circle, to avoid breaking the front glass.

A water and oil-repellent GORE-TEX membrane air vent in the floor of the main housing between the heat exchanger cowling and rear cover equalizes pressure differences and expels moisture as the luminaire heats up and cools down. If this seal is blocked or incorrectly installed, condensation can build up and pressure differences can suck moisture into the luminaire.

8.4.1 Seals

To maintain the luminaire's resistance to dust and moisture, it is important to replace silicone seals carefully after removal. The seals should maintain their sealing ability for the life of the luminaire, but examine them when servicing the luminaire and replace any seal

that is cracked, torn, brittle, or inflexible. Replacement seals may be ordered from Martin Architectural. For part numbers, see Table 3 on page 60.

The seals must extend 0.5 - 1 mm (1/64 - 1/32 in.) beyond the outside of the casing. If you can feel the seal when you run a finger across the joint, that's enough. Seals will be effective if they are flush with casings, but if they are below the casing's edge, they can collapse into the luminaire and let water in.

The recommended procedure for closing all covers is the same:

1. Ensure that the seal and mating surfaces are clean.
2. Place the cover and seal firmly against the housing. Adjust the straight sides of the seal so that they stick out a little, just enough so that you can feel the edge of the seal when you run a finger across the joint.
3. Cross-tighten (i.e. tighten diagonally) retaining screws gradually and evenly to the torque settings specified in Table 3 on page 60.

8.4.2 **Cable glands**

Provision is made for cables to enter the luminaire through IP68-rated cable glands that accept:

- power cable with an external diameter of 8 - 13 mm (0.32 - 0.5 in.) and
- data cable with an external diameter of 5.5 - 10 mm (0.22 - 0.39 in.)

The cable glands must be replaced with suitably dimensioned items if the diameter of cable used is not within this range.

Replacement glands, available from electrical suppliers, must have the following characteristics:

Temperature range	-20° to +70° C (-4° to 158° F) or better
Ingress protection rating	IP67 minimum
Minimum entry thread length	8 mm

8.4.3 Torque settings

The torque settings for the yoke screws as well as screws holding covers and part numbers for the corresponding seals are as shown below.

To ensure that the Exterior 1200 Wash is waterproof and to avoid damaging threads, a torque driver with a range from 2 Nm (1.5 ft.-lbs.) to 16 Nm (11.8 ft.-lbs.) must be used during service and adjustment.

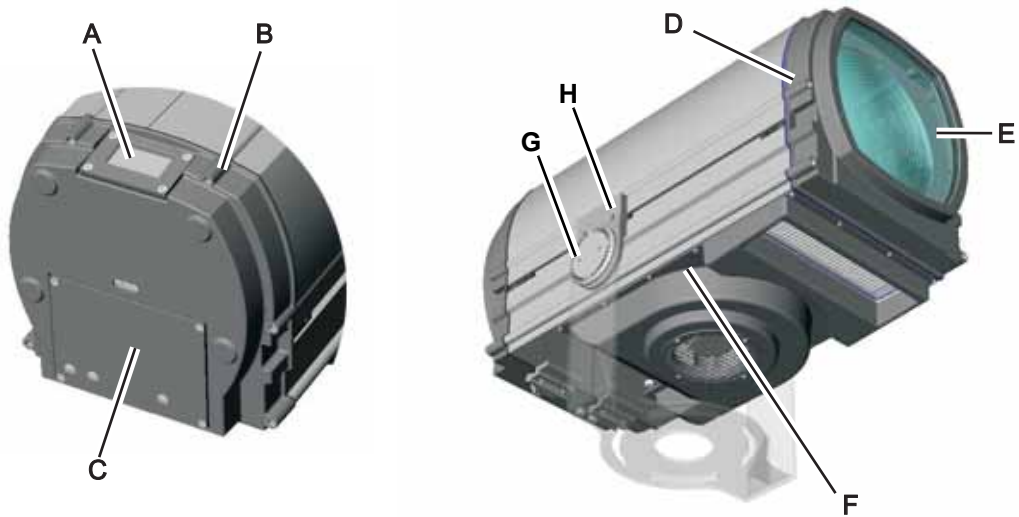

Figure 17: Torque settings

Component	Torque setting	Seal P/N
A - Display cover	2 Nm (1.5 ft.-lbs.)	20620160
B - Rear cover	7 Nm (5.2 ft.-lbs.)	20620130
C - Connections box	2 Nm (1.5 ft.-lbs.)	20620150
D - Front cover	7 Nm (5.2 ft.-lbs.)	20620130
E - Front glass (screws inside luminaire)	2 Nm (1.5 ft.-lbs.)	20620140
F - Cooling fan housing	2 Nm (1.5 ft.-lbs.)	No seal fitted
G - Tilt lock	16 Nm (11.8 ft.-lbs.)	No seal fitted
H - Yoke slider	16 Nm (11.8 ft.-lbs.)	No seal fitted

Table 3: Torque settings and seal part numbers

8.5 Lamp maintenance

8.5.1 *Approved lamp*

Important! The Exterior 1200 Wash is designed to use only the lamp specified below. Installing any other model may cause damage to the luminaire that is not covered by the product warranty.

Lamp	Average life	Color temp.	CRI (Ra8)	Output
Philips MSD 1200	3000 hours	6000 K	80	92 000 lm

Table 4: Lamp specifications

Data subject to change. Refer to lamp manufacturer's specifications for latest information.

8.5.2 *Lamp life and monitoring lamp hours*

A discharge lamp's quartz bulb weakens over time, significantly increasing the risk of lamp explosion. Always replace a discharge lamp before it reaches the limit of its average life (see table above). In large installations, replacing all lamps at the same time will simplify replacement schedules.

The Exterior 1200 Wash has built-in resettable counters that you can use to monitor the number of hours the lamp has been used and the number of times the lamp has been struck (started). The counters can be checked in the onboard control panel or using the MUM application. Check the counter as necessary, and reset the luminaire's Resettable Lamp Hours and Resettable Lamp Strikes counters each time you install a new lamp

A. Checking and resetting the lamp life counters using the onboard control panel

The onboard control panel displays the lamp hours and lamp strike counters in the **Lamp Status** display every few seconds until you enter the control menus.

To reset the counters using the onboard control panel:

1. Open the **Personality** menu, navigate to the counters and press **Enter** to display.
2. To return the resettable lamp hours and lamp strikes counters to zero, select **Reset all counters**, press **Enter** and confirm.

B. Checking and resetting the lamp life counters using MUM

To reset the counters:

1. Connect a PC and DABS1 adaptor to the Exterior 1200 Wash via the service port in the connections compartment.
2. Power on the Exterior 1200 Wash and start the MUM application. The application will automatically detect an Exterior 1200 Wash if it is powered on and correctly connected. It will also retrieve the current settings on the luminaire and display them.

- Using MUM, click on the **Fixture Info** button.
- The **Resettable Lamp-on hours** will be displayed. Click on the **Reset** buttons beside **Resettable Lamp-on hours** and **Resettable Lamp Strikes** to return these figures to zero.

Reset	Resettable Power-on hours 2
Reset	Resettable Lamp-on hours 2
Reset	Resettable Lamp Strikes 33

8.5.3 *Installing the lamp*



Warning! Switch off the lamp, allow the luminaire to cool with fans running for 20 minutes, then isolate it from AC power and lock out power before servicing.

Wear safety glasses and gloves while installing or inspecting the lamp.

To replace the lamp:

- Cut lamp power, allow the luminaire to cool with fans running for 20 minutes, then isolate it from AC power and lock out power.
- See Figure 18. Loosen the six Allen head screws holding the front cover and remove the cover and its silicone seal. Avoid damaging the seal during removal. If you do not remove the seal, you may damage it and will make access more difficult.

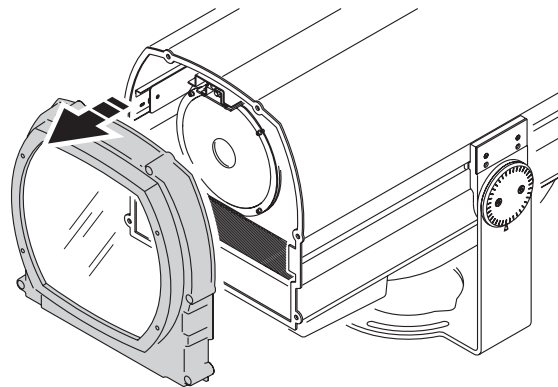

Figure 18: Removing the front cover and seal

3. See Figure 19. Pull out the slider locks in the sliders on each side at the front of the housing.
4. Slide the lamp/effects module out of the housing, avoiding strain on internal wiring. Note that a lamp cutout mechanism is activated as soon as the module is moved from its normal position.

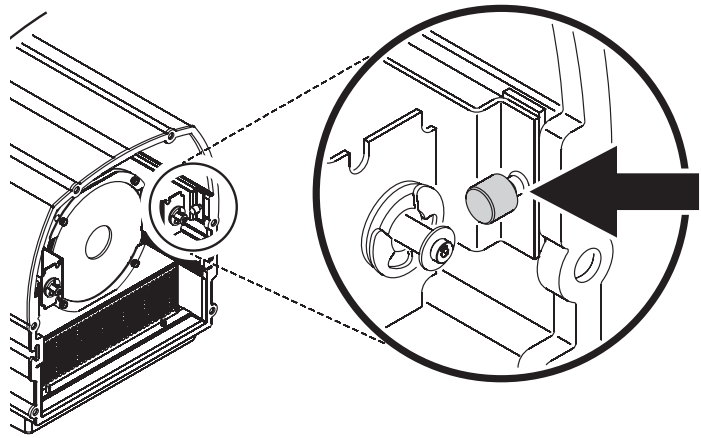

Figure 19: Slider lock

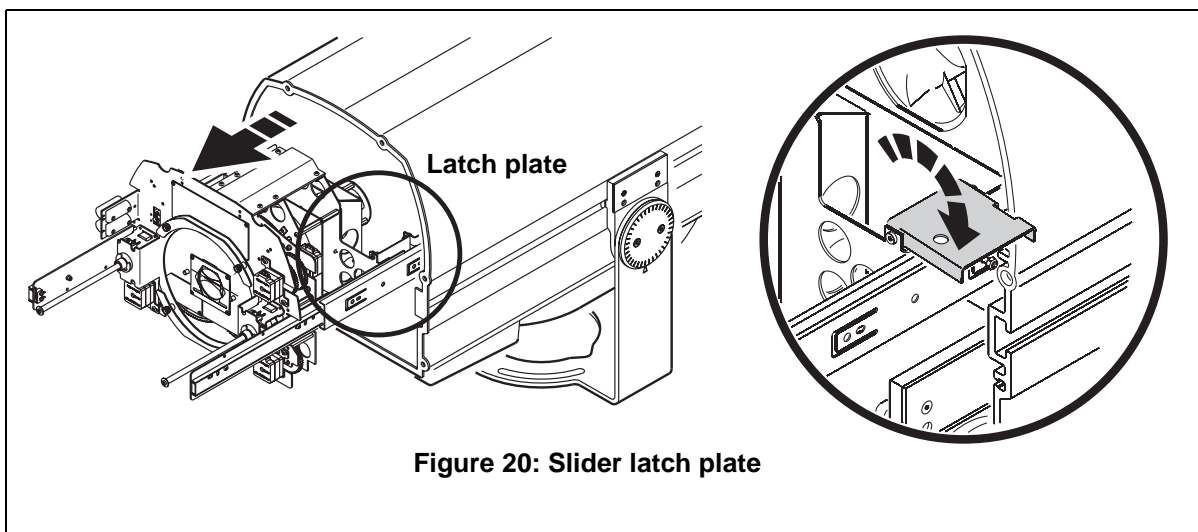

Figure 20: Slider latch plate

5. See Figure 20. Flip open the latch plate to lock the module in the out position.
6. See Figure 21. The lampholder is at the rear of the effects modules. Loosen, but do not remove, the three Allen screws (arrowed) holding the lampholder. To release the lampholder, push it in slightly towards the modules and rotate it so that the holes in the lampholder plate clear the Allen screws, then gently pull the lampholder clear. Avoid touching or knocking the lamp against other components.

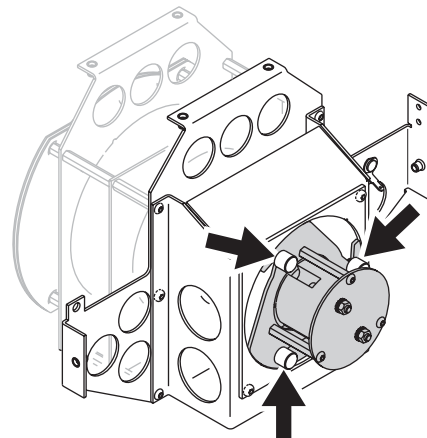

Figure 21: Lampholder screws

7. If replacing an old lamp, remove it from the socket.
8. The new lamp's glass bulb must be perfectly clean. Do not touch it with your fingers. Clean it using the wipe supplied with the lamp. A clean, lint-free cloth wetted with 99.9% isopropyl alcohol may also be used.
9. Holding the new lamp by its ceramic base, insert it firmly and squarely into the lamp socket.
10. Re-insert the lampholder in its original position, pushing and twisting it to lock it in place on the three Allen screws. Check that lamp wiring is also in its original position.
11. Tighten the lampholder screws.
12. Push the effects/lamp module back into the housing. Make sure that the slider locks click into place to ensure that the module is correctly positioned and the lamp cutout mechanism is deactivated.
13. Before reinstalling the front cover, check the condition of the seal. Replace with a new item if the seal is torn, cracked or brittle.
14. Place the front cover and seal firmly against the housing. Adjust the straight sides of the seal so that they stick out a little, just enough so that you can feel the seal when you run a finger across the joint.
15. Cross-tighten the cover screws, tightening gradually to a torque of 7 Nm (5.2 ft.-lbs.). At this torque, the seal will be compressed by about one-third.
16. Reapply power and return the resettable lamp hours and lamp strikes counters to zero. See "8.5.2: Lamp life and monitoring lamp hours" on page 61.

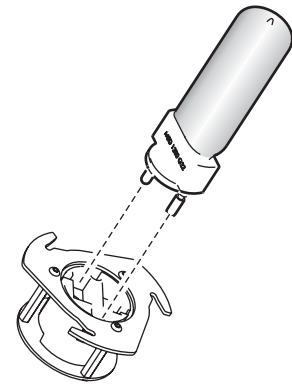

Figure 22: Lamp socket

Lamp alignment is factory-set. If after installing a new lamp the Exterior 1200 Wash has a noticeable hot-spot or dark area in the centre of the beam, or if the brightest part of the beam is significantly off-center, the lamp may need to be realigned. Please contact your Martin Architectural supplier for assistance.

8.6 Installing color filters

As standard, the Exterior 1200 Wash is supplied with CTC (5500 K to 3400 K), red, green and blue dichroic color filters installed in the color wheel. Filters can be replaced if other colors are required.

The Exterior 1200 Wash also features a holder for a permanent filter. A CTC filter can be installed in this holder to match the color temperature of the light output precisely with other luminaires.

Filters can be ordered from Martin Architectural.

For best performance, install filters with the coated surface facing away from the lamp. Filters must be perfectly clean and free of grease when installed. Wear clean cotton gloves to avoid contaminating filters with oil from your fingers. If necessary, clean filters with a soft lint-free cloth wetted with 99.9% isopropyl alcohol.

To install a color filter:

1. Open the luminaire and slide the effects module out of the luminaire housing as described in "8.5.3: Installing the lamp" on page 62.

2. See Figure 23. To install a permanent filter, slide the filter fully into the filter holder (**B**) so that it is held securely by the clip.
3. To install a filter on the color wheel, remove the two Torx 10 retaining screws (**A**) from the filter access plate and remove the plate.

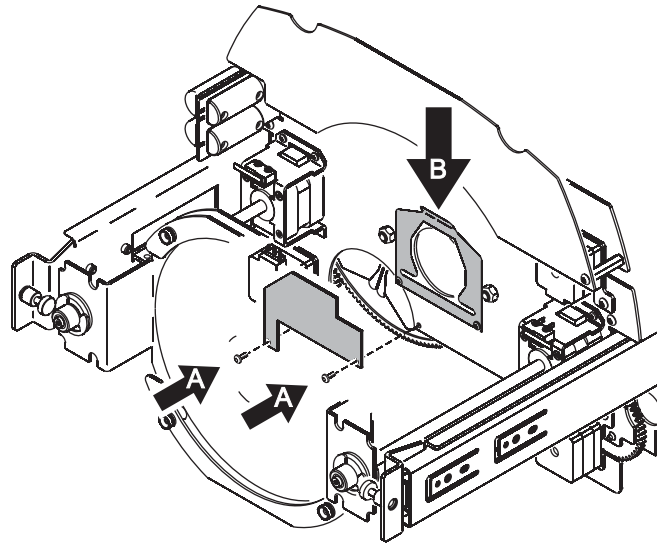

Figure 23: Filter replacement

4. To remove a filter, use a small flathead screwdriver to lift the filter support leaves on the color wheel. Lift the filter slightly and slide it out.
5. To install a filter, lift the filter support leaves and slide the new filter into place on the color wheel. Make sure that it is held securely by the retaining lugs (**C** in Figure 24).
6. Reinstall the filter access plate.
7. Slide the effects module back into the luminaire housing and close the luminaire as described in "8.5.3: *Installing the lamp*" on page 62 before reapplying power.

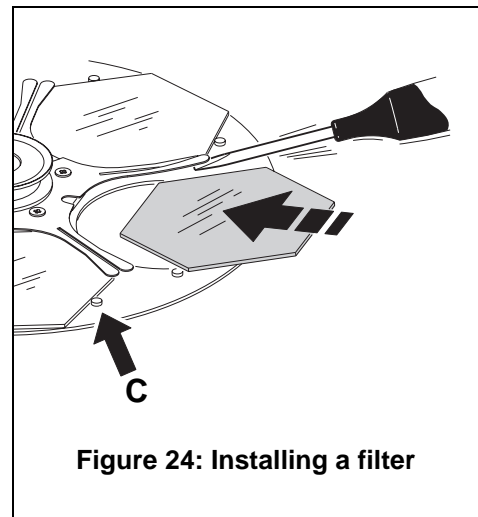
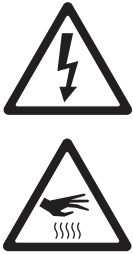

Figure 24: Installing a filter

8.7 Replacing fuses



Warning! Switch off the lamp, allow the luminaire to cool with fans running for 20 minutes, then isolate it from AC power and lock out power before replacing a fuse.

The Exterior 1200 Wash is protected by two 15 amp slow blow main fuses (P/N 05020050) located in fuseholders behind the rear cover plate. One fuse protects the connection labelled “Live 1”, and one protects “Live 2”. If the luminaire fails to respond when power is applied, one of these may have blown.

To replace a main fuse:

1. Switch off the lamp, allow the luminaire to cool with fans running for 20 minutes, then isolate it from AC power and ensure that power cannot be reconnected accidentally.
2. Remove the rear cover plate as described in "3.1.4: Connections compartment access" on page 18.
3. The two main fuses are located in fuseholders in the connections compartment. Use a torx screwdriver to open the fuseholders and remove the fuses.
4. Replace the defective fuse with one of the same size and rating. Replace the fuseholders.
5. Reinstall the cover plate as described in "3.1.4: Connections compartment access" on page 18.

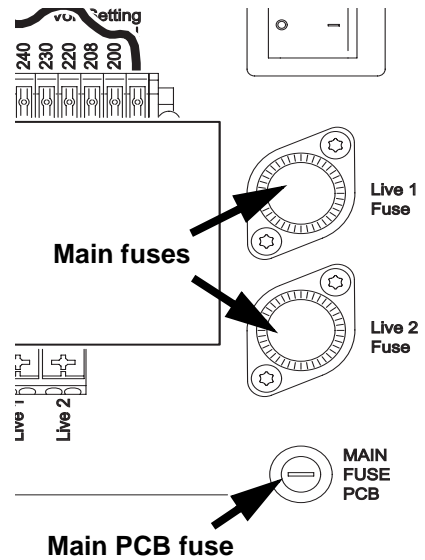

Figure 25: Fuses

If neither of the main fuses are defective, check and if necessary replace the 10 amp slow blow main PCB low-voltage fuse (P/N 05020025) with one of the same type and rating.

8.8 Software-based service functions

8.8.1 Adjustment and monitoring

MUM, the MP-2 Uploader and the onboard control panel all contain an **Adjustment** function. This is a tool for mechanical adjustment and effect calibration, and is for use by Martin Global Service and its authorized agents.

The **Monitor** function in MUM and the onboard control panel is for use primarily by Martin Global Service and its authorized agents, but can be a means of obtaining information that is useful for problem diagnosis.

- To view monitoring information in MUM, connect the luminaire to MUM via a DABS1 interface as described in "5.1.1: Setting up a luminaire with a PC and MUM" on page 33, then click on the **Monitor** button. As well as hardware monitoring information, software and bootloader version details are displayed.

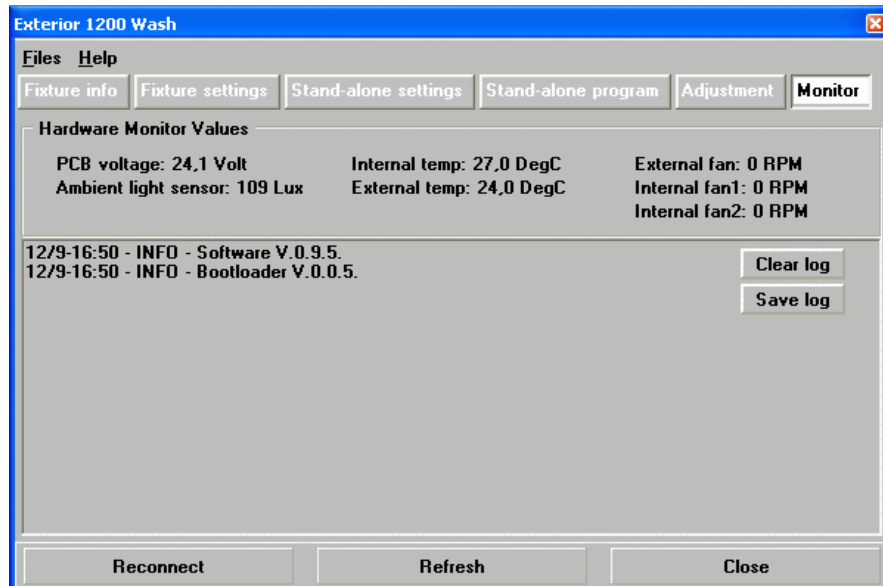

- To view monitoring information in the onboard control panel, scroll through the **Info** menu.

8.8.2 Restoring factory defaults

The Exterior 1200 Wash factory default settings can be restored, if required.

Restoring using MUM

The most secure way of restoring factory defaults using MUM is to download the current luminaire software version from the Martin website and upload it to the luminaire using one of the upload options in the **Files** menu.

Restoring via an MP-2

To restore factory defaults using an MP-2 Uploader, use the **Personality → Factory default** command.

Restoring via the onboard control panel

To restore factory defaults using the onboard control panel, use the **Personality → Factory default** command.

8.8.3 Software updates

The most recent software versions for all Martin Architectural products are available free of charge from the Support area of the Martin website at <http://www.martin.com>

If the Exterior 1200 Wash software needs to be updated, the software can be downloaded and then installed using a Martin MP-2 Uploader or a PC with Martin Software Uploader shareware (also available free of charge from the Martin website). The PC must be connected to the Exterior 1200 Wash via a hardware interface. The following hardware interface devices are currently supported:

- DABS1 PC/luminaire hardware interface
- ShowDesigner PCI DMX Interface Card (2048 channel version)
- LightJockey PCI DMX Interface Card (512 and 2048 channel versions)
- LightJockey PCMCIA DMX Interface
- LightJockey 4064 ISA DMX Interface Card (DJ and Club versions)

Intermediate control systems such as the Martin Lighting Director (MLD) and the Martin Matrix must be bypassed when updating luminaire software via the data link because they do not relay the update code correctly.

Before updating software, read the release notes to familiarize yourself with any changes in functionality or any special instructions.

Some software releases may require a boot mode upload or a boot sector update. If so, contact your Martin Architectural supplier for assistance.

Software updates (DMX/Auto mode upload)

To update software, connect an upload device either to the data input of the luminaire via the DMX data link or to the RJ-45 service port located behind the rear cover plate, and perform a DMX mode upload as described in the upload device's documentation. If uploading via the DMX data link, there is no need to isolate Exterior 1200 Wash luminaires from other types of luminaires on the link.

When the upload is completed (and when booting up) the Exterior 1200 Wash performs a check-sum test of the memory and then resets.

In the unlikely event that a software upload is interrupted, the luminaire must be powered off for at least 10 seconds and then powered on again to force a check-sum test. You can then repeat the DMX mode upload. If an error occurs during subsequent uploads and the luminaire does not reset, data may have been interrupted or corrupted during transmission. A boot mode upload will almost certainly rectify this problem.

Important! Boot mode uploads must be carried out by Martin Global Service or its authorized agent. If you suspect that a boot mode upload is necessary, please contact your Martin Architectural supplier for assistance.

8.9 Troubleshooting

Problem	Probable cause(s)	Remedy
No response from luminaire when power is applied.	No power to luminaire.	Check power cables.
	Main or low-voltage fuse blown.	Replace fuse.
	Secondary fuse(s) blown (located on PCB).	Refer to Martin Architectural.
Luminaire resets when power applied but does not respond correctly to DMX controller. LED 2 lights steady green.	Incorrect DMX addressing.	Check luminaire addressing on controller. If no error found, check luminaire's DMX address setting.
Luminaire resets when power applied but does not respond correctly to DMX controller. LED 2 does not light steady green.	Bad data link connection.	Inspect cables and correct poor connections and/or broken cables.
	Data link not terminated.	Insert DMX termination resistor in data output of last luminaire on each branch of the data link.
Luminaire resets when power applied but does not respond correctly to DMX controller. LEDs flash red and green.	Defective luminaire.	Bypass luminaires on the data link one at a time until normal operation is regained.
	Electronic or mechanical failure.	Refer to Martin Architectural.
	Luminaire software corrupted.	Upload new software. If luminaire repeatedly fails to reset correctly, refer to Martin Architectural for boot mode upload.
Luminaire cuts out intermittently, especially in hot weather.	Luminaire temperature too high: thermal cutout shutting down power to avoid overheating.	Stop using luminaire. Inspect for dirt buildup and clean if necessary. If luminaire is clean or if problem reoccurs, stop using luminaire and refer to Martin Architectural.
No light output.	Lamp has been in use and is too hot to restrike.	Allow to cool for 8 minutes before attempting to restrike.
	Lamp defective or worn out.	Replace lamp.
	Lamp cutout inside front cover not correctly deactivated.	Open front cover. Make sure that left-hand slider lock presses cutout switch.
	Power settings do not match local AC voltage and frequency.	Disconnect luminaire and open rear cover. Check jumper lead settings and correct if necessary.
	Temperature or fans error	Check display for error message. Check for dirt buildup. Check that ambient temperature does not exceed maximum. Refer to Martin Architectural.
Lamp life unexpectedly short (note that 3000 hours is <i>average</i> life, not <i>minimum</i>).	Defective lamp.	Replace lamp.
	Strain on lamp or excessive lamp strikes.	Always allow lamp to fully warm up for five minutes before turning off. Leave lamp powered and use intensity command to reduce light output to zero if only cutting light output for short periods. Leave power applied for at least 8 minutes after switching off lamp to allow cooling fans to reduce temperature.

8.10 Accessories

This section lists the optional accessories available for the Exterior 1200 Wash. You can find an updated list on the Martin Architectural website at <http://www.martin-architectural.com>.

Installation instructions are included with all accessories and can also be downloaded from the Support area of the Martin Architectural website.

Beam shaper lens

A beam shaper lens is available as an optional accessory for Exterior 1200 Wash Narrow and Medium beam angle models. The beam shaper flattens and widens the beam into an elliptical shape. It can be rotated manually to adjust the axis of the beam so that a tall vertical or wide horizontal beam is projected.

Custom color filters

A range of dichroic color filters, including various CTC filters, is available from Martin suppliers.

5500-4200 K CTC kit

The Color Temperature Control (CTC) kit consists of a dichroic color filter that can be permanently installed in the lamp/effects module. With the filter fitted, color temperatures are reduced, giving warmer colors but with slightly reduced light output. The shift in color temperatures corresponds to a reduction from 5500 to 4200 K.

Snoot/barndoor kit

The snoot/barndoor kit consists of plates that can be installed around the Exterior 1200 Wash front glass using supplied hardware in order to limit beam angle and control light overspill or glare.

Section 9. Reference

9.1 Connections compartment

The connections compartment behind the rear cover plate contains the elements illustrated below:

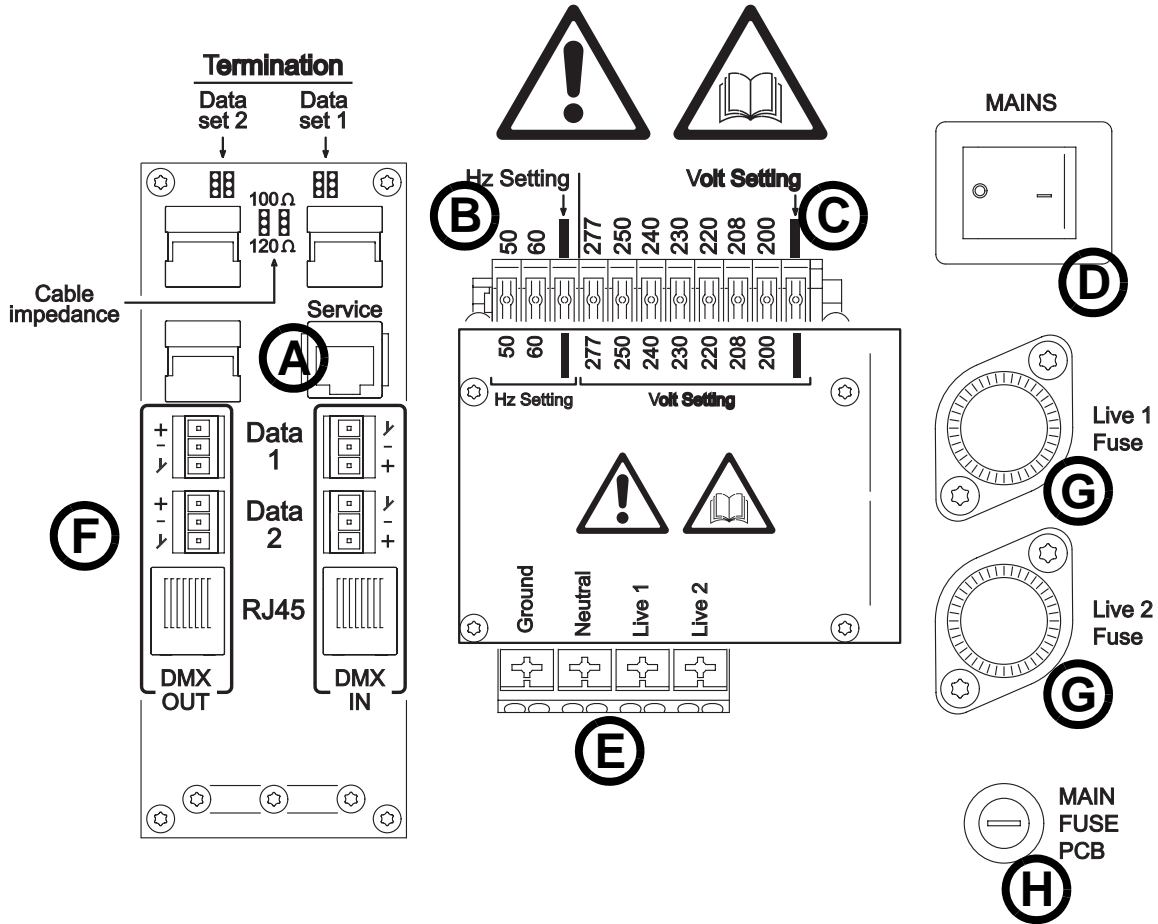

- A - Service port (RJ-45 socket)
- B - AC power frequency setting jumper
- C - AC power voltage setting jumper
- D - Main power on/off switch

- E - AC power connection terminals
- F - DMX connection terminals
- G - Main fuseholders
- H - PCB (low voltage) fuseholder

9.2 LED status messages

Appearance	Message, LED 1	Message, LED 2
Steady green	Effects OK	Data OK.
Steady red	-	Invalid data/no data
Steady yellow	Waiting for upload, or upload in progress	Waiting for upload, or upload in progress
Flashing yellow	Reset in progress	Reset in progress
Flashing red & green	See message in display or contact a service technician	
Off	-	No data detected

Table 5: LED status messages

The three-digit version number (*major.minor.build*) of the installed software is displayed by the LEDs on power up. The number of:

- Red flashes in LED 1 indicates the major number, followed by,
- Green flashes in LED 2 to indicate the minor number, followed by,
- Red flashes in LED 2 to indicate the build number (only used for beta releases)

For example, if the software version is 1.3.0, LED 1 flashes red once and LED 2 flashes green three times.

9.3 Onboard control panel menus

Menu	Options	Notes	
Fixture address	1 - 503	Set the luminaire's DMX address	
Standalone	Enable SA	Enable stand-alone operation	
	SA Execution	Single	Set luminaire to independent stand-alone operation
		Master	Set luminaire as master in master/client synchronized stand-alone operation
		Synchronized	Set luminaire as client in master/client synchronized stand-alone operation
Personality	DMX Lamp off	When enabled, allows lamp to be turned off via DMX	
	DMX Reset	When enabled, allows luminaire to be reset via DMX	
	Auto lamp on	When enabled, turns lamp on as soon as power is applied to luminaire	
	Fan regulation	When enabled, cooling fan speed is temperature-regulated (when disabled, fans run at full speed)	
	Display Errors	When enabled, gives priority in the display to error messages	
	Setup °C/°F	Set temperature readouts to Centigrade or Fahrenheit	
	Set backlight level	Set brightness of display backlighting (0 - 100)	
	Set clock	Set real-time clock	
	Reset counters	Reset all counters	
	Load Factory Default	Return all luminaire settings to factory default	
Info	Version	Displays main luminaire software and control panel display software versions	
Manual	Fixture reset	Reset luminaire	
	Set lamp On	Turn on lamp	
	Set lamp Off	Turn off lamp	
	Set Intensity	Set shutter position (1 - 255)	
	Set Cyan	Set cyan position (1 - 255)	
	Set Magenta	Set magenta position (1 - 255)	
	Set Yellow	Set yellow position (1 - 255)	
	Set Colorwheel	Set color wheel position (1 - 255)	
	Set Zoom	Set zoom position (1 - 255)	
Utility (press for 3 seconds to activate menus)	Adjust	Fixture reset	Reset luminaire
		Set lamp On	Turn on lamp
		Set lamp Off	Turn off lamp
		Adjust effects	All – Zoom: open or close effects (for adjustment and test purposes)
	Force Upload	Prepare luminaire for boot mode software upload	

9.4 MP-2 control menus

Menu	Options	Notes	
Fixture address	1 - 503	Set the luminaire's DMX address	
	Enable SA	Enable/disable stand-alone operation	
SA Execution	Single	Set luminaire to independent stand-alone operation	
	Master	Set luminaire as master in master/client synchronized stand-alone operation	
	client	Set luminaire as client in master/client synchronized stand-alone operation	
Light Level	Enable	Enable ambient light level triggering of stand-alone operation	
	Level	Enter value to set triggering light level	
	Capture	Set current ambient light level as triggering light level	
Timer	Enable	Enable timer-controlled operation	
	Timer 1	Set start and stop times for timer 1 (first daily operation period)	
	Timer 2	Set start and stop times for timer 2	
Stand Alone	Intensity	Set intensity	
	Cyan	Set amount of cyan	
	Magenta	Set amount of magenta	
	Yellow	Set amount of yellow	
	Color wheel	Select filter on color wheel	
	Zoom	Set zoom value	
	Fade time	Pick table	lets you select a fade time from Snap (instant) to 2 m 0 s (two minutes)
		Custom	lets you define a custom fade time by entering values for hours, minutes and seconds
	Wait time	Pick table	lets you select a wait time from 0s (scene fades to the next with no wait time) to 2 m 0 s (scene is held for two minutes fading to the next)
		Custom	lets you define a custom wait time
	Add scene	Save settings in a new scene at the end of the current sequence of scenes	
	Next scene	Step to the next scene	
	Previous scene	Step to the previous scene	
	Store scene	Save settings in the current scene	
	Insert scene	Add settings in a new scene immediately before the current scene	
	Delete scene	Delete the current scene	
	Clr all scenes	Clear all scenes from memory	
	Run program	Run the programmed light show	

Menu	Options	Notes
Adjust	Reset	Reset luminaire
	Lamp on	Turn on lamp
	Lamp off	Turn off lamp
	Real time clock	Set the 24-hour on-board clock
	All effects	Open or close all effects
	Intensity	Open or close shutter
	Cyan	Open or close cyan filter
	Magenta	Open or close magenta filter
	Yellow	Open or close yellow filter
	Color wheel	Select color wheel position
	Zoom	Move zoom to near or far position
Personality	DMX Lamp off	When enabled, allows lamp to be turned off via DMX
	DMX Reset	When enabled, allows luminaire to be reset via DMX
	Auto lamp on	When enabled, turns lamp on as soon as power is applied to luminaire
	Display Errors	When enabled, gives priority in the display to error messages
	Fan regulation	When enabled, cooling fan speed is temperature-regulated (when disabled, fans run at full speed)
	Setup °C/°F	Set temperature readouts to Centigrade or Fahrenheit
	Set backlight level	Set brightness of display backlighting (0 - 100)
	Factory default	Return all luminaire settings to factory default
	Reset counters	Reset all counters
Version	X.X	Displays currently installed luminaire software version

9.5 DMX protocol

DMX channel	Value	Percent	Function
1	0 - 208	0 - 81	Reset, lamp on/off Reserved: selecting this value has no effect Reset ⁽¹⁾ Reserved: selecting this value has no effect Lamp power on Reserved: selecting this value has no effect Lamp power off: value must be held for 5 seconds ⁽²⁾
	208 - 217	81 - 85	
	218 - 227	85 - 87	
	228 - 237	89 - 93	
	238 - 247	93 - 97	
	248 - 255	97 - 100	
2	0 - 255	0 - 100	Intensity Intensity 0 → 100%
3	0 - 255	0 - 100	Cyan White → cyan
4	0 - 255	0 - 100	Magenta White → magenta
5	0 - 255	0 - 100	Yellow White → yellow
6	0 - 9	0 - 3	Color Wheel Stepped Scroll Color 1 - White (open) Color 2 - CTC Color 3 - Red Color 4 - Green Color 5- Blue Reserved: selecting this value has no effect
	10 - 19	4 - 7	
	20 - 29	8 - 11	
	30 - 39	12 - 15	
	40 - 49	16 - 18	
	50 - 255	19 - 100	
7	0 - 255	0 - 100	Zoom (Narrow and Medium models) Wide → narrow
8	0 - 2	0 - 1	Effects (intensity, CMY and zoom) speed Tracking mode Vector mode fast → slow Reserved: selecting this value has no effect Color wheel speed Tracking mode Vector mode fast → slow Reserved: selecting this value has no effect
	3 - 245	2 - 95	
	246 - 255	96 - 100	
	0 - 2	0 - 2	
	3 - 245	3 - 245	
	246 - 255	246 - 255	

⁽¹⁾ If DMX reset without confirmation is disabled in the control menus (**Personality** → **DMX Reset**), the Exterior 1200 Wash can still be reset via DMX if confirmation is given by setting channels 3 (cyan), 4 (magenta) and 5 (yellow) to a value of 230 - 232.

⁽²⁾ If DMX lamp off without confirmation is disabled in the control menus (**Personality** → **DMX Lamp off**), the lamp can still be powered off via DMX if confirmation is given by setting channels 3 (cyan), 4 (magenta) and 5 (yellow) to a value of 230 - 232.

Exterior 1200 Wash specifications

Physical

Length.....	860 mm (33.9 in.)
Width including mounting yoke	448 mm (17.6 in.)
Height including mounting yoke.....	620 mm (24.4 in.)
Weight.....	68 kg (150 lbs.)
EPA (Effective Projected Area)	0.6 m2 (6.5 sq. ft.)

Lamp

Type	1200 W metal halide
Approved model.....	Philips MSD 1200
Lamp socket	G22
Control	Automatic and/or remote on/off

Dynamic Effects

Color mixing.....	Independently variable continuous CMY
Cyan	0 - 100%
Magenta.....	0 - 100%
Yellow.....	0 - 100%
Color wheel.....	Red, green, blue, 5500 - 3400 K CTC (as standard) and white (open)
Dimmer	0 - 100%
Zoom, Narrow model, fresnel optics (one-tenth peak angle).....	14° - 31°
Zoom, Medium model, fresnel optics (one-tenth peak angle).....	20° - 50°

Control and Programming

Control options	DMX, stand-alone, synchronized (master/client)
DMX channels	8
DMX address setting	MUM (Multi-Utility Manager), MP-2, onboard control panel
Stand-alone programming	MUM, MP-2, onboard control panel
Stand-alone trigger options	Internal timer and light-level sensor
Stand-alone memory	20 scenes
Protocol	USITT DMX-512A
Receiver.....	RS-485

Photometric Data

Narrow, zoom at spot position

Efficiency	31%
Half-peak angle.....	8°
Total output	28 600 lm

Narrow, zoom at flood position

Efficiency	31%
Half-peak angle.....	16°
Total output	28 200 lm

Narrow, zoom at spot position, with beam shaper lens accessory

Efficiency	29%
Half-peak angle, C ₀	20°
Half-peak angle, C ₉₀	9°
Total output	26 400 lm

Narrow, zoom at flood position, with beam shaper lens accessory

Efficiency	27%
Half-peak angle, C ₀	25°
Half-peak angle, C ₉₀	17°
Total output	24 400 lm

Medium, zoom at spot position

Efficiency	22%
Half-peak angle.....	12°
Total output	20 200 lm

Medium, zoom at flood position

Efficiency	31%
Half-peak angle.....	29°
Total output	28 800 lm

Wide

Efficiency	38%
Half-peak angle.....	44°
Total output	34 500 lm

Very wide

Efficiency	37%
Half-peak angle.....	48°
Total output	33 700 lm

Construction

Housing	Aluminum
Finish	Clear anodized
Front glass	6 mm, anti-reflection coated
Color filters	1.2 mm, dichroic, hexangular
Protection factor.....	UL wet location, main enclosure IP65

Installation

Orientation	Any (air intake must face down)
Minimum distance to combustible materials	1 m (40 in.)
Minimum distance to illuminated surfaces	1 m (40 in.)
Minimum clearance around heat exchanger cowling.....	135 mm (5.5 in.)
Minimum clearance from top of luminaire to building member	150 mm (6 in.)
Minimum clearance from center of fixture to side building member	400 mm (16 in.)
Minimum center-to-center distance in side-by-side installation	800 mm (31.5 in.)

Connections

Power cable entry	IP68 cable gland
Power connection	Quick connectors
Data cable entry	IP68 cable gland
Data connection.....	RJ-45 or screw terminal/quick connectors

Electrical

AC power	200/208/220/230/240/250/277 V nominal, 50/60 Hz
Main fuse	15 AT (slow blow)
Ballast.....	Magnetic

Typical power and current*

200 V, 50 Hz	1380 W, 7.0 A, PF 0.975
200 V, 60 Hz	1405 W, 7.3 A, PF 0.960
208 V, 60 Hz	1417 W, 7.1 A, PF 0.958
220 V, 50 Hz	1373 W, 6.4 A, PF 0.973
230 V, 50 Hz	1365 W, 6.1 A, PF 0.973
240 V, 50 Hz	1370 W, 5.9 A, PF 0.973
250 V, 50 Hz	1364 W, 5.6 A, PF 0.972
277 V, 60 Hz	1417 W, 5.4 A, PF 0.956

*Figures listed are typical, not maximum. Measurements taken at nominal voltage. Allow for +/- 10% variation. PF = Power factor.

Thermal

Maximum ambient temperature (Ta).....	45° C (113° F)
Minimum ambient temperature (Ta).....	- 20° C (- 4° F)
Maximum surface temperature, steady state, Ta=45° C	90° C (194° F)
Total heat dissipation (calculated, +/- 10%)	4950 BTU/hr.
Cooling	Forced air, integrated air/air heat exchanger, IP65 barrier

Approvals



US safety (pending)	UL 1598
Canadian safety (pending).....	CSA C22.2 No. 250.0-00
EU safety	EN 60 598-1, EN 61 347-1
EU EMC.....	EN 55 015, EN 55 103-1, EN 61 000-3

Included Items

Philips MSD 1200 lamp	P/N 97010313
Two M16 x 1.5 IP68 cable glands, metal, cable diameter 5.5 - 10 mm (0.22 - 0.39 in.)	P/N 13102030
One M20 x 1.5 IP68 cable gland, metal, cable diameter 8 - 13 mm (0.32 - 0.5 in.)	P/N 13102090
Four M16 cable entry blanking plugs (installed), metal, with neoprene seals	P/N 13102050
Two M20 blanking plugs (installed), metal, with neoprene seal	P/N 13103030
Two main fuses, 15 AT (installed)	P/N 05020050
PCB fuse, 10 AT (installed).....	P/N 05020025
User manual	P/N 35000177

Accessories

Elliptical beam shaper lens	P/N 91610081
Snoot/barndoor kit	P/N 91611257
5500-4200 K CTC filter	P/N 91611258
Custom color and CTC filters.....	Contact Martin for details

Related Items

MUM (Multi Utility Manager) incl. DABS interface & cables.....	P/N 90758090
MP-2 Uploader	P/N 90758420

Ordering Information

Exterior 1200 Wash, Narrow (14° - 31°)	P/N 90504010
Exterior 1200 Wash, Medium (20° - 50°).....	P/N 90504020
Exterior 1200 Wash, Wide (60°)	P/N 90504030
Exterior 1200 Wash, Very Wide (97°)	P/N 90504040

Specifications subject to change without notice



Disposing of this product

Martin[®] products are supplied in compliance with Directive 2002/96/EC of the European Parliament and of the Council of the European Union on WEEE (Waste Electrical and Electronic Equipment), as amended by Directive 2003/108/EC, where applicable.

Help preserve the environment! Ensure that this product is recycled at the end of its life. Your supplier can give details of local arrangements for the disposal of Martin[®] products.

Notes



www.martin-architectural.com • Olof Palmes Allé 18 • 8200 Aarhus N • Denmark
Tel: +45 8740 0000 • Fax +45 8740 0010