

Exterior Dot-HP Pro

User manual

with Safety and Installation Manual



Martin[®]

©2025 HARMAN PROFESSIONAL DENMARK ApS. All rights reserved. Features, specifications and appearance are subject to change without notice. HARMAN PROFESSIONAL DENMARK ApS and all affiliated companies disclaim liability for any injury, damage, direct or indirect loss, consequential or economic loss or any other loss occasioned by the use of, inability to use or reliance on the information contained in this document. Martin is a registered trademark of HARMAN PROFESSIONAL DENMARK ApS registered in the United States and/or other countries.

HARMAN PROFESSIONAL DENMARK ApS, Olof Palmes Allé 44, 8200 Aarhus N, Denmark
HARMAN PROFESSIONAL, INC., 8500 Balboa Blvd., Northridge CA 91325, USA

www.martin.com

Exterior Dot-HP Pro combined User Manual and Safety Manual, English, P/N 5152482-00, Revision A

Table of contents

Introduction	4
Exterior Dot-HP Pro	4
Before using the product for the first time.....	4
System layout diagrams.....	4
Setting up the Exterior Dot-HP Pro.....	9
Setting up using a Martin P3 controller.....	9
Setting up using RDM.....	9
Martin Companion.....	9
RDM communication.....	9
Fixture discovery.....	11
Setting up for DMX control.....	12
Dimming curves	13
Behavior when no DMX signal is present.....	13
Power limit mode	13
LED refresh modes	13
Color modes.....	14
CTC.....	14
Tint	14
Utilities	14
Supported parameters	14
Fixture information	14
Status messages	15
Setting up standalone operation	16
Creating a standalone show	16
Operating the Exterior Dot-HP Pro	21
Test sequences and fixture status.....	21
Controlling via DMX	21
Identifying fixtures in the installation.....	21
Pixel layout.....	22
DMX protocols.....	23
Standard Mode	23
Extended Mode.....	23
Direct Mode.....	26
RGB Mode	26
PixelMap Mode	26
FX overview	27
FX list.....	29

Introduction



Warning! Before installing, operating or servicing the Exterior Dot-HP Pro creative LED lighting system, read the latest version of the Exterior Dot-HP Pro Safety and Installation Manual, paying particular attention to the Safety Precautions section. The Safety and Installation Manual is supplied with products and also included at the back of this user manual.

Important! Full specifications for Exterior Dot-HP Pro products and accessories are available in the Exterior Dot-HP Pro area of the Martin® website at www.martin.com.

Thank you for selecting the Exterior Dot-HP Pro from Martin.

This User Guide is a supplement to the Safety and Installation Manual that is supplied with products and attached to the back of this User Manual. This combined User Manual plus Safety and Installation Manual is available for download from the Exterior Dot-HP Pro area of the Martin website. The User Manual contains information that is mainly of interest for lighting designers and operators, whereas the Safety and Installation Manual contains important information for all users, especially installers and technicians.

We recommend that you check the Martin website regularly for updated documentation. We publish revised versions each time we can improve the quality of the information we provide and each time we release new firmware with changes or new features. Each time we revise this guide we list any important changes on page 2 so that you can keep track of updates.

Exterior Dot-HP Pro

The Exterior Dot-HP Pro family from Martin is a powerful, compact and energy-efficient line of LED dots designed to illuminate mid-sized structures and building facades. Dots are IP67-rated and are suited to permanent outdoor use.

Each Dot has 16 x RGBW pixels. Depending on DMX mode, pixels can be controlled together or separately. Dots can be controlled using video mapping via a Martin P3 System Controller or using DMX via any Art-Net or sACN DMX controller. Extended DMX Mode also lets you crossfade between P3 and DMX control of Dots. You can use RDM via Art-Net to set up Dots, including setting up standalone operation in which Dots can display a single scene with no external control required. Protocol detection is automatic.

Before using the product for the first time

1. Check the support pages on the Martin Professional website at www.martin.com for the most recent user documentation and technical information about the product. Martin® user manual revisions are identified by the revision letter at the bottom of the inside cover.
2. Read the product's Safety and Installation Manual included at the back of this User Manual before installing, operating or servicing the product.
3. Unpack and ensure that there is no transportation damage before using the product. Do not attempt to operate a damaged product.
4. Install the product as described in the product's Safety and Installation Manual and this User Manual.
5. Remove protective film (if fitted) from optical components before applying power.

System layout diagrams

The diagrams on the following pages show examples of possible Exterior Dot-HP Pro layouts. See also the diagrams that are available for download from the Exterior Dot-Pro HP area of www.martin.com.

Respect the safety limits for maximum cable lengths given in the Exterior Dot-Pro HP Safety and Installation Manual supplied with Dots and attached to the end of this User Manual.

Example layout using a P3 PowerPort 2000

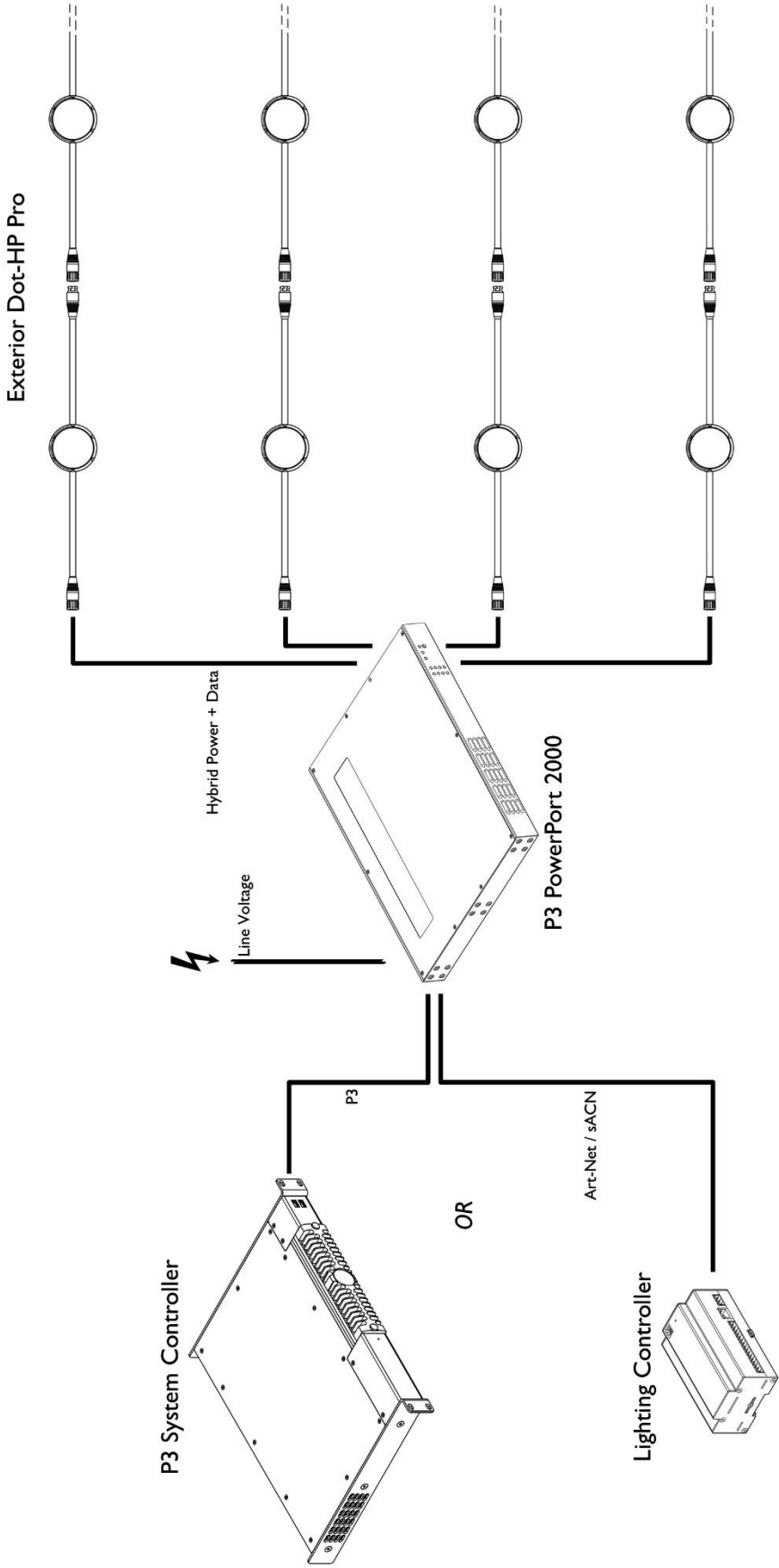

Example layout using a P3 PowerPort 500 IP Install

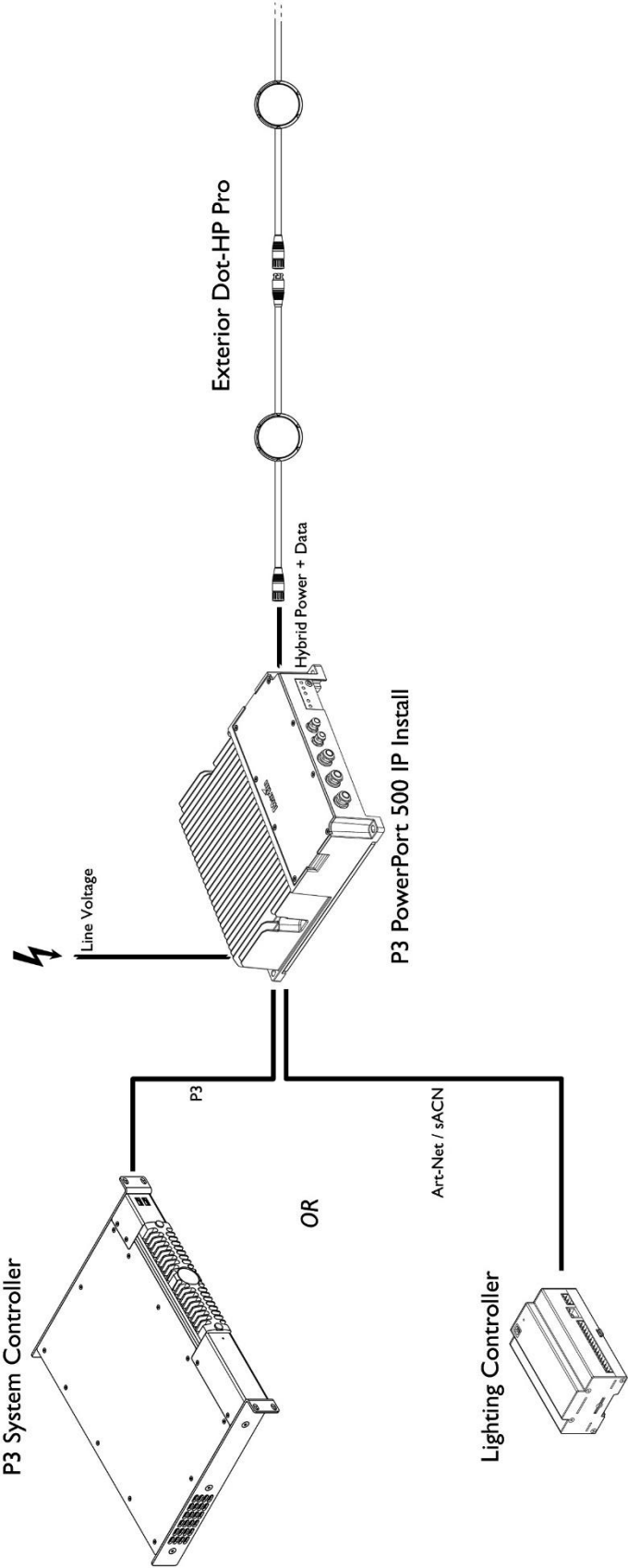

Example layout using a DCE PSU 240 IP

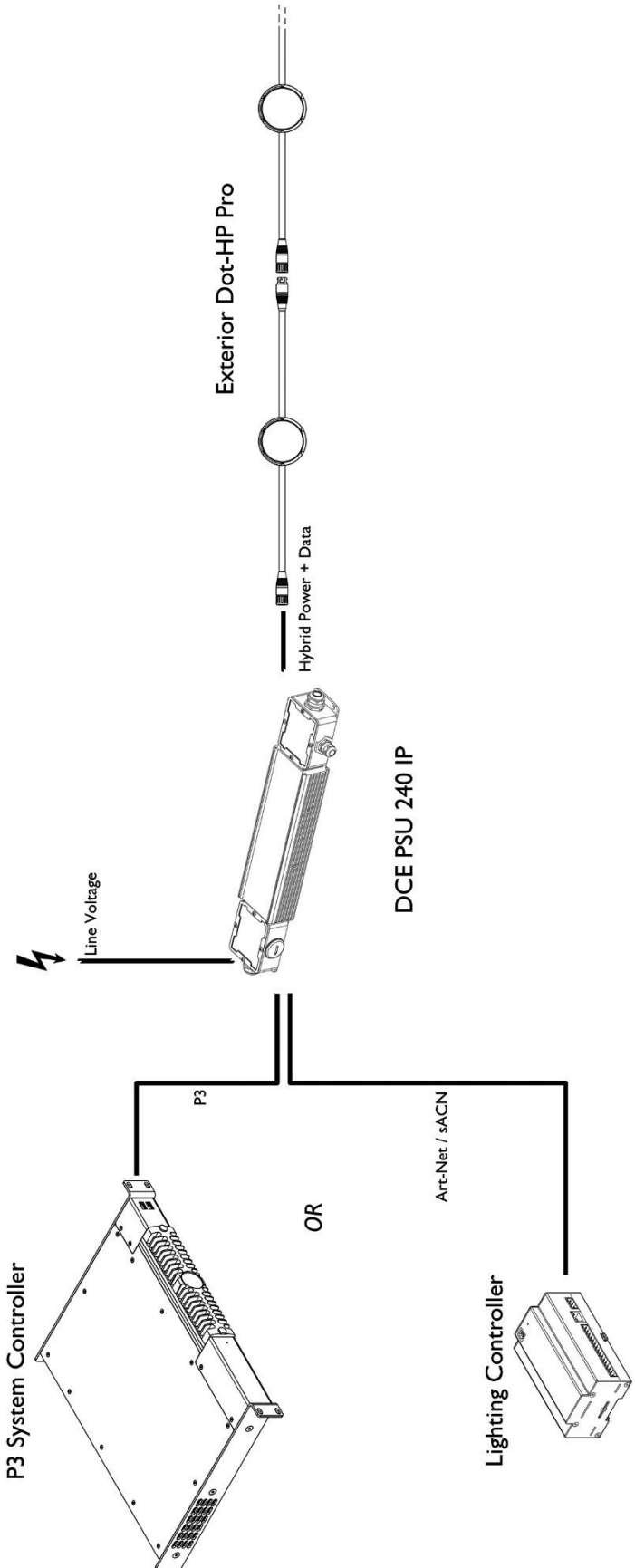

Splitting a hybrid link using a DCE Splitter/Booster IP

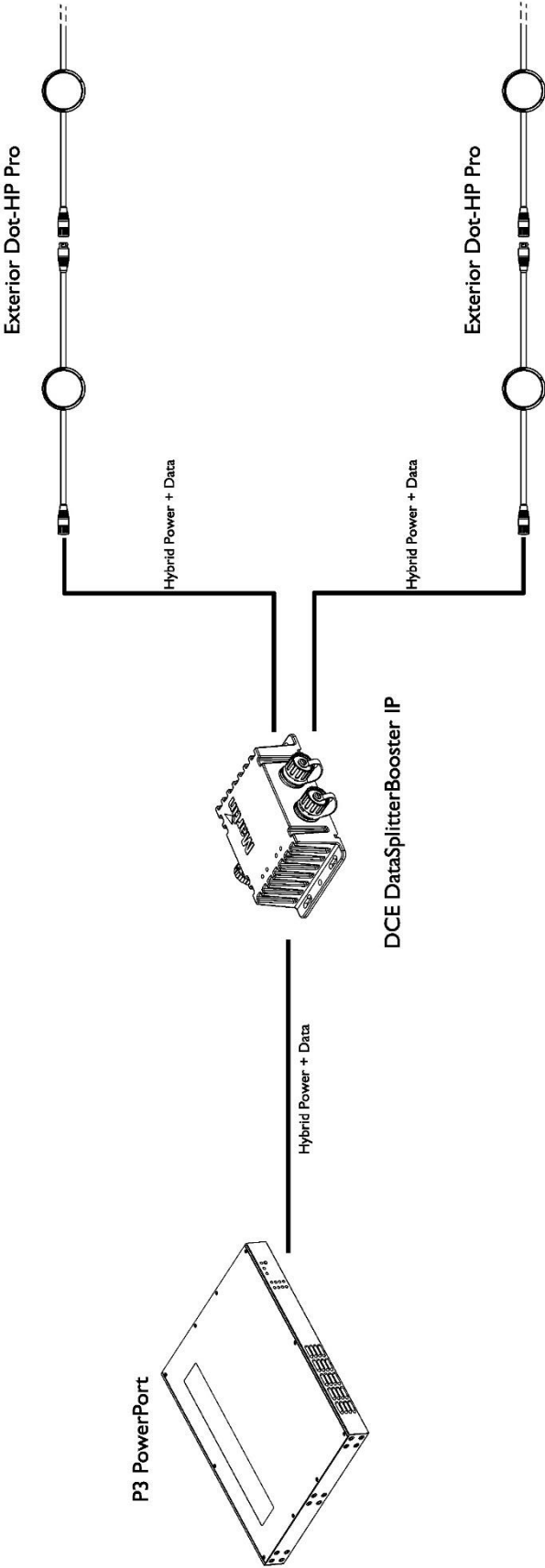

Setting up the Exterior Dot-HP Pro



Warning! Read “Safety information” and “Precautions to avoid damage” in the Safety and Installation manual that is supplied with products and included at the end of this User Manual before applying power to an Exterior Dot-HP Pro installation.

You can set up the Exterior Dot-HP Pro using a Martin P3 controller, an RDM-compatible DMX controller or the Martin Companion Windows application running on a PC connected to the data link. The settings listed in this chapter are all available using both P3 and RDM.

Setting up using a Martin P3 controller

A Martin P3 system allows video to be displayed on an installation that contains Exterior Dot-HP Pro Dots. When a P3 controller is connected to the installation and the installation is powered on, you can set up the Dots from the P3 controller. See the P3 System Controller user manual for details.

Setting up using RDM

If you are connected to Exterior Dot-HP Pro Dots via an Ethernet link, you can set up the Dots from a PC using any RDM-compatible controller via Art-Net. It is possible to use sACN to control Dots, but for setup you need to use RDM via Art-Net.

Martin Companion

If you are connected to Exterior Dot-HP Pro Dots via an Ethernet link, you can set up the Dots from a PC using the Martin Companion Windows application via Art-Net. Note that Martin Companion cannot communicate via sACN.

The Martin Companion software suite for Windows can be downloaded free of charge from the Martin website at www.martin.com. The Martin Companion software suite will always offer the latest Exterior Dot-HP Pro features and firmware when your PC is connected to the Internet.

Martin Companion offers the following features:

- Simple PC-based user interface
- Update of product firmware
- RDM configuration and addressing
- Standalone show programming with up to twenty scenes and an option to start the show automatically when fixtures are powered on.

RDM communication

The Exterior Dot-HP Pro responds to the RDM parameter IDs (PIDs) listed in the table below:

RDM DISCOVERY

DISC_UNIQUE_BRANCH
DISC_MUTE
DISC_UN_MUTE

STATUS INFORMATION

GET SET

	GET	SET	
QUEUED_MESSAGE	✓		Get queued messages
STATUS_MESSAGES	✓		Get status/error information
STATUS_ID_DESCRIPTION	✓		Status/error description
CLEAR_STATUS_ID		✓	Clear status/error queue

RDM INFORMATION**GET SET**

SUPPORTED_PARAMETERS	✓		List supported PIDs
PARAMETER_DESCRIPTION	✓		Supported PIDs description

PRODUCT INFORMATION**GET SET**

DEVICE_INFO	✓		Get basic info
DEVICE_MODEL_DESCRIPTION	✓		Product name
MANUFACTURER_LABEL	✓		Manufacturer name
DEVICE_LABEL	✓	✓	User- settable label
FACTORY_DEFAULTS	✓	✓	Restore factory defaults
SOFTWARE_VERSION_LABEL	✓	✓	Firmware version
SERIAL_NUMBER	✓		Factory serial number

DMX SETUP**GET SET**

DMX_PERSONALITY	✓	✓	DMX mode
DMX_PERSONALITY_DESCRIPTION	✓		DMX mode name
DMX_START_ADDRESS	✓	✓	DMX address
SLOT_DESCRIPTION	✓		DMX channel description

ETHERNET SETUP**GET SET**

LIST_INTERFACES	✓		List Ethernet ports
INTERFACE_LABEL	✓		Name of Ethernet port
INTERFACE_HARDWARE_ADDRESS_TYPE1	✓		MAC address of Ethernet port
IPV4_DHCP_MODE	✓		Enable/Disable DHCP client
IPV4_CURRENT_ADDRESS	✓		Get current IP address
IPV4_STATIC_ADDRESS	✓	✓	Set static IP address
INTERFACE_APPLY_CONFIGURATION		✓	Apply Ethernet configuration

USAGE INFORMATION**GET SET**

DEVICE_HOURS	✓	✓	Counter, total number of hours powered on
DEVICE_POWER_CYCLES	✓	✓	Counter, total number of power cycles
LAMP_HOURS	✓	✓	Counter, total number of hours LEDs powered on
SENSOR_DEFINITION	✓		Sensor description
SENSOR_VALUE	✓		Sensor readout

CONTROL	GET	SET	
IDENTIFY_DEVICE	✓	✓	Highlight device in installation
RESET_DEVICE		✓	Warm/Cold Reset
PERFORM_SELFTEST	✓	✓	Perform self-test
SELF_TEST_DESCRIPTION	✓		Self-test description

STANDALONE OPERATION	GET	SET	
CAPTURE_PRESET		✓	Capture current DMX scene
PRESET_PLAYBACK	✓	✓	Play standalone scene
MANUAL_MODE_OVERRIDE	✓	✓	Remote manual control
PRESET_PLAYBACK_LIMIT	✓	✓	Standalone cue counter
SYNCHRONIZED	✓	✓	Sync mode in standalone operation
OFFLINE_MODE	✓	✓	Behavior when no DMX signal present

DEVICE SETTINGS	GET	SET	
FIXTURE_ID	✓	✓	User-changeable fixture ID number
COLOR_MODE	✓	✓	Set color mode
DIMMER_CURVE	✓	✓	Set dimmer curve
VIDEO_TRACKING	✓	✓	Video tracking On/Off
HIBERNATION_MODE	✓	✓	Enable/Disable hibernation
LOW_NOISE_LED_MODE	✓	✓	Enable/Disable Low Noise mode (high PWM frequency)
POWER_LIMIT_MODE	✓	✓	Limit power per Dot
MANUAL_CTC_VALUE	✓	✓	Set CTC in DMX Mode that does not have CTC control
MANUAL_TINT_VALUE	✓	✓	Set Tint in DMX Mode that does not have Tint control

Fixture discovery

Before you can communicate with Dots using RDM, you must send a scan command (fixture discovery command) to all the devices on the data link so that the RDM controller can identify them. It does this by retrieving each device's factory-set unique identifier (UID). This process can take some time, depending on the number of devices on the link.

To identify the Dots on the link:

1. Check that the Dots are correctly connected to the RDM controller on the data link and that power is applied to all Dots.
2. Send a discovery command via RDM (Martin Companion does this automatically as soon as the cable is connected).
3. Give the controller time to identify the devices on the link and prepare for communication with the devices.

Setting up for DMX control

DMX controllers send control data to devices over DMX control channels in DMX universes. One DMX universe has 512 channels available. Multiple Dots can share the same DMX channels if you want grouped control and identical Dot behavior.

The Exterior Dot-HP Pro system can be controlled using a DMX-over-Ethernet connection such as Art-Net or sACN.

DMX control in the Exterior Dot-HP Pro offers 0 - 100% variable intensity RGB or RGBW control, Color Temperature Control variable from 1800 K to 12850 K a virtual color wheel with 49 Lee-referenced color presets, a pixel mapping mode that lets you control 16 individual pixels per Dot, and a range of pre-programmed dynamic FX that run on complete Dots or on individual pixels.

Setting DMX mode

The Exterior Dot-HP Pro can be set to any of the following five DMX modes (see “DMX protocols” on page 23):

- In Standard Mode, each Dot is controlled as one unit and uses six DMX channels.
- In Extended Mode, each Dot is controlled as one unit and uses twelve DMX channels. Extended Mode gives access to the range of dynamic FX.
- In Direct Mode, each Dot is controlled as one unit and uses four DMX channels for RGBW control.
- In RGB Mode, each Dot is controlled as one unit and uses three DMX channels for RGB control.
- In Pixelmap Mode, you can control the 16 pixels in each Dot individually with RGB control using 48 DMX channels.

Different modes can be mixed in an installation. For example, some Exterior Dot-HP Pro Dots can be set to Standard Mode and others to Pixelmap Mode. Allocating DMX addresses and DMX channels in a mixed installation will require some planning.

Because DMX mode affects the number of DMX channels a Dot uses, it will affect the assignment of DMX addresses to Dots. It is therefore a good idea to set the DMX mode of all the Dots in the installation before you set their DMX addresses.

The DMX_PERSONALITY PID lets you set the DMX mode of a Dot via RDM.

Setting DMX addresses

To prepare an installation for DMX control, you need to set it up so that Dots receive instructions from the controller on their own DMX channels.

A Dot's DMX address is the first DMX channel it uses to receive control data. It uses this channel and the channels immediately above it. If a Dot has DMX address 001 and the Dot uses four DMX channels, it will use channels 001, 002, 003 and 004. DMX address 005 will be available as a DMX address for the next Dot on the data link. If this Dot also uses four DMX channels, the next available DMX address will be 009, and so on.

You can set the DMX address of one Dot by sending a unicast RDM command to that one Dot only, or you can set all the Dots on the data link to the same DMX address by sending a broadcast RDM command to all the Dots on the link. If all the Dots have the same DMX address, they will behave identically and you will not be able to control any single Dot independently.

For instructions on setting DMX addresses using Martin companion, see 'Setting DMX addresses' on page 16.

Dimming curves

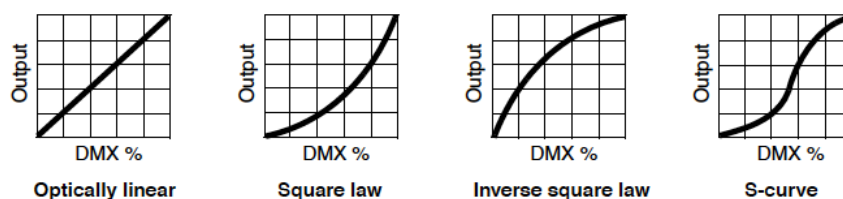

Four dimming curves are available via RDM using the DIMMER_CURVE PID:

- Optically linear – The increase in light intensity appears to be linear as DMX value is increased.
- Square law (default setting) – light intensity control is finer at low levels and coarser at high levels.
- Inverse square law – Light intensity control is coarser at low levels and finer at high levels.
- S-Curve – light intensity control is finer at low levels and high levels and coarser at medium levels.

Behavior when no DMX signal is present

The OFFLINE_MODE command lets you define how Dots behave if power is applied but Dots are not receiving a DMX signal (or if Dots are powered on and being controlled by DMX, and then the DMX signal stops).

Four options are available:

- Blackout (default setting) – Intensity set to zero light output when no DMX signal is present.
- Standalone – Dot switches to standalone operation when no DMX signal is present. If you have programmed a scene or scenes using Martin Companion as described later in this User Manual, the Dots will display that scene when no DMX signal is present.
- Hold Last State – Dots follow the last DMX values received.
- Full Output – All LEDs go to 100% intensity when no DMX signal is present.

Power limit mode

The POWER_LIMIT_MODE command lets you set Dots to full or half power via RDM.

You can also set Dots to full or half power by moving a physical switch inside Martin P3 PowerPort 500 IP, P3 PowerPort 2000 IP and Exterior AC-Feeder devices as well as by adjusting Dot settings in Martin P3 System Controllers.

Setting Dots to half power can be useful for night-time or TV studio applications, for example, where full power is not needed or may be undesirable. The HALF setting also lets you connect a higher number of Dots, meaning that an installation will require fewer system components.

LED refresh modes

You can set the Exterior Dot-HP Pro to one of two refresh rates via RDM or P3:

- Standard refresh mode (default): 1001 Hz
- High refresh mode (for which the RDM PID is LOW_NOISE_MODE): 4004 Hz.

In High refresh mode, dimming is in 14-bit resolution. In Standard refresh mode, dimming is in 16-bit resolution.

For camera applications, we recommend using High refresh mode.

Color modes

The Exterior Dot-HP Pro has four color modes: Direct, Extended Gamut, Calibrated Color and Linear Video.

When a Dot is set to Direct DMX control mode, it is fixed in **Direct** Color Mode – you cannot select a calibrated color mode.

When a Dot is set to Standard, Extended, RGB or Pixelmap DMX control mode, you can select from three color modes via RDM:

- **Extended Gamut** (default setting) – The White point and mixed colors are calibrated, but you can saturate colors to the maximum level available. No brightness calibration is used, so you may observe minor brightness differences between individual Dots.
- **Calibrated Color** – The entire color gamut is calibrated, resulting in a slight loss of color saturation. Additionally, the brightness of each Dot is calibrated for best consistency.
- **Linear Video** – The entire color gamut is calibrated, resulting in a slight loss of color saturation. Additionally, the brightness of each Dot is calibrated and adjusted so that the product behaves like a video screen.

CTC

The MANUAL_CTC_VALUE command lets you set a default color temperature for Dots when controlling them in a DMX Mode that does not offer CTC.

Tint

The MANUAL_TINT_VALUE command lets you adjust the tint of Dots.

Utilities

The Exterior Dot-HP Pro offers various functions to help you manage Dots:

- If you apply an IDENTIFY_DEVICE command to a Dot, it will flash a signal to let you know which Dot you are communicating with. This can be useful when setting up Dots in a large installation.
- RESET_DEVICE – Carries out a full reset of the Dot's electronics.
- SELF_TEST_DESCRIPTION – Lets you select from various sequences that test the Dot's functionality and LEDs.
- PERFORM_SELFTEST – Runs a test sequence.
- FACTORY_DEFAULTS – Deletes any custom settings that have been configured via RDM and returns a Dot to its factory default settings.

Supported parameters

Exterior Dot-HP Pro Dots can communicate the control parameters that they support to the RDM controller and give brief information on each parameter.

Fixture information

The Exterior Dot-HP Pro can communicate the following information to the RDM controller:

- Basic fixture information – type of fixture.
- Name of product and manufacturer.
- Device label – This information can be edited by the user, providing a means of giving an individual Dot its own ID number, for example.
- Currently installed firmware version.
- Number of hours Dot has had power applied since manufacture (non-resettable).
- Number of hours LEDs have been active since manufacture (non-resettable).
- Number of on/off power cycles since manufacture (non-resettable).
- Serial number – This is a factory-set serial number that cannot be changed.

Status messages

The Exterior Dot-HP Pro features a self-diagnostic system that detects any issues concerning correct operation or safety (temperature that exceeds safe level, for example) and communicates the issues as status messages or warnings. These messages can be useful in connection with service and maintenance.

It is possible to:

- Call up a list of any status messages that the fixture has stored in memory.
- View information on the messages.
- Clear the stored list of status messages.

Setting up standalone operation

In standalone mode, the Exterior Dot-HP Pro can display a ‘scene’ (a color, an intensity or a dynamic FX etc.) or a ‘show’ that can contain up to twenty scenes if you use Martin Companion. Once standalone scenes have been programmed, Dots can display them without needing a control signal.

You can program standalone operation using the Martin Companion Windows application that is available for download free of charge from www.martin.com. Standalone programming using Martin Companion offers the following advantages:

- Standalone show with up to twenty standalone scenes
- Standalone scenes with global or individual fade and hold times
- Easy programming of multiple Dots simultaneously
- Different types of Martin lighting fixture in one standalone show
- Possibility of automatic standalone show start when Dots are powered on.

Standalone operation is only possible if no DMX/RDM signal is present. If you connect a DMX signal to Dots that are running a standalone show, they will stop standalone operation and respond to DMX control.

You must connect the PC running Martin Companion to Dots via the Art-Net link.

Creating a standalone show

To program a standalone show using Martin Companion, first connect a PC running the Martin Companion application to the Art-Net link. Apply power to the Dots on the link that you want to program.

Setting DMX addresses

To set up DMX addresses:

1. Execute a **Discover** command to obtain a list of connected fixtures.

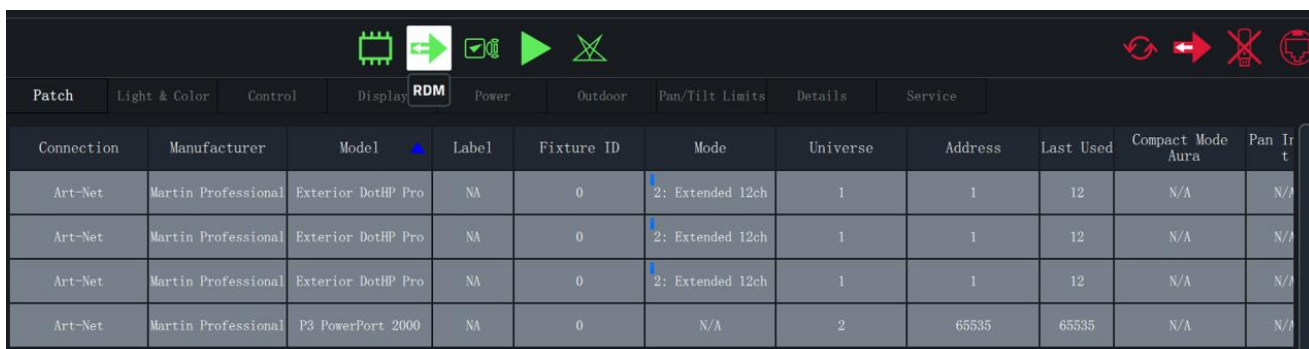

Connection	Manufacturer	Model	Label	Fixture ID	Mode	Universe	Address	Last Used	Compact Mode Aura	Pan Tilt
Art-Net	Martin Professional	Exterior DotHP Pro	NA	0	2: Extended 12ch	1	1	12	N/A	N/A
Art-Net	Martin Professional	Exterior DotHP Pro	NA	0	2: Extended 12ch	1	1	12	N/A	N/A
Art-Net	Martin Professional	Exterior DotHP Pro	NA	0	2: Extended 12ch	1	1	12	N/A	N/A
Art-Net	Martin Professional	P3 PowerPort 2000	NA	0	N/A	2	65535	65535	N/A	N/A

2. Select **Patch** and go to the **Address** column, where you can edit Dots’ addresses.

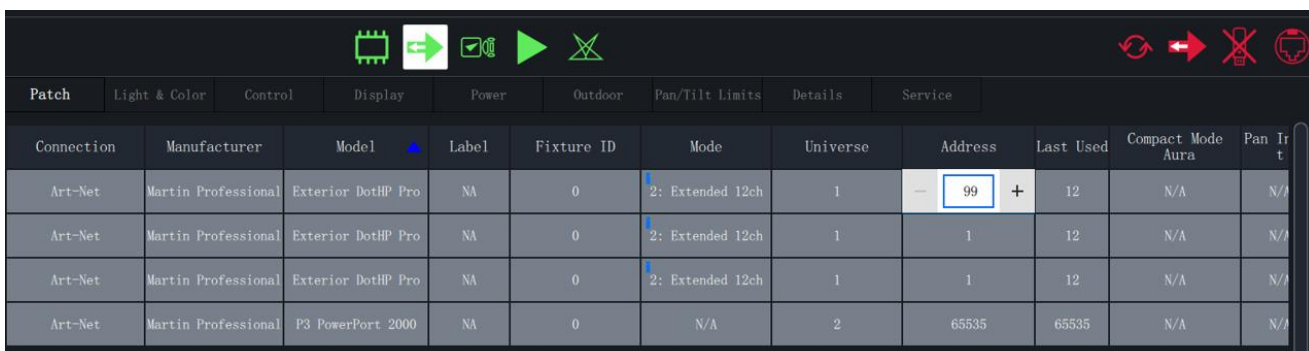

Connection	Manufacturer	Model	Label	Fixture ID	Mode	Universe	Address	Last Used	Compact Mode Aura	Pan Tilt
Art-Net	Martin Professional	Exterior DotHP Pro	NA	0	2: Extended 12ch	1	99	12	N/A	N/A
Art-Net	Martin Professional	Exterior DotHP Pro	NA	0	2: Extended 12ch	1	1	12	N/A	N/A
Art-Net	Martin Professional	Exterior DotHP Pro	NA	0	2: Extended 12ch	1	1	12	N/A	N/A
Art-Net	Martin Professional	P3 PowerPort 2000	NA	0	N/A	2	65535	65535	N/A	N/A

Programming standalone operation

To set up standalone operation:

1. Execute a **Discover** command to obtain a list of connected fixtures. Then click on **Standalone**:

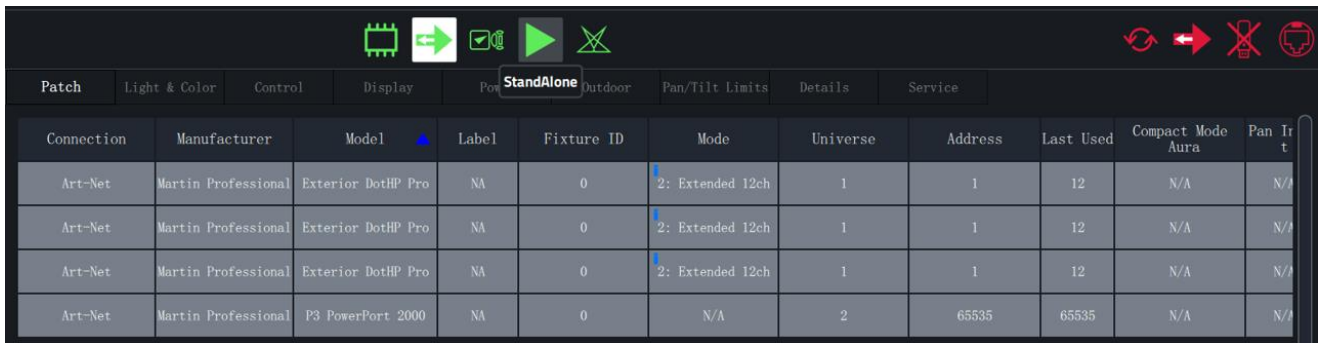

2. Select the Dot or Dots that you want to program in the **StandAlone** section:



3. Click on **CREATE** and create the first scene using the control faders. Click on **ADD SCENE** and continue creating scenes until your show is complete:

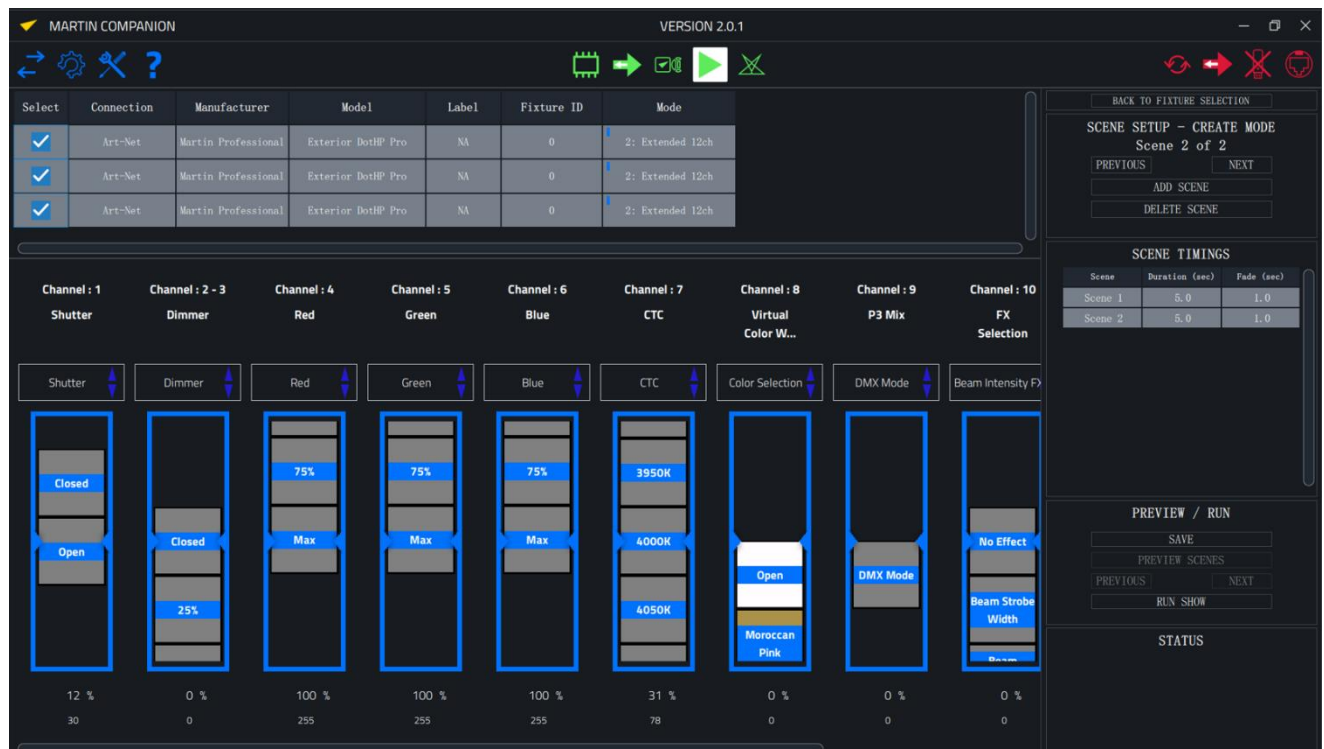

4. Click on **SAVE** to save the scenes that you have created:

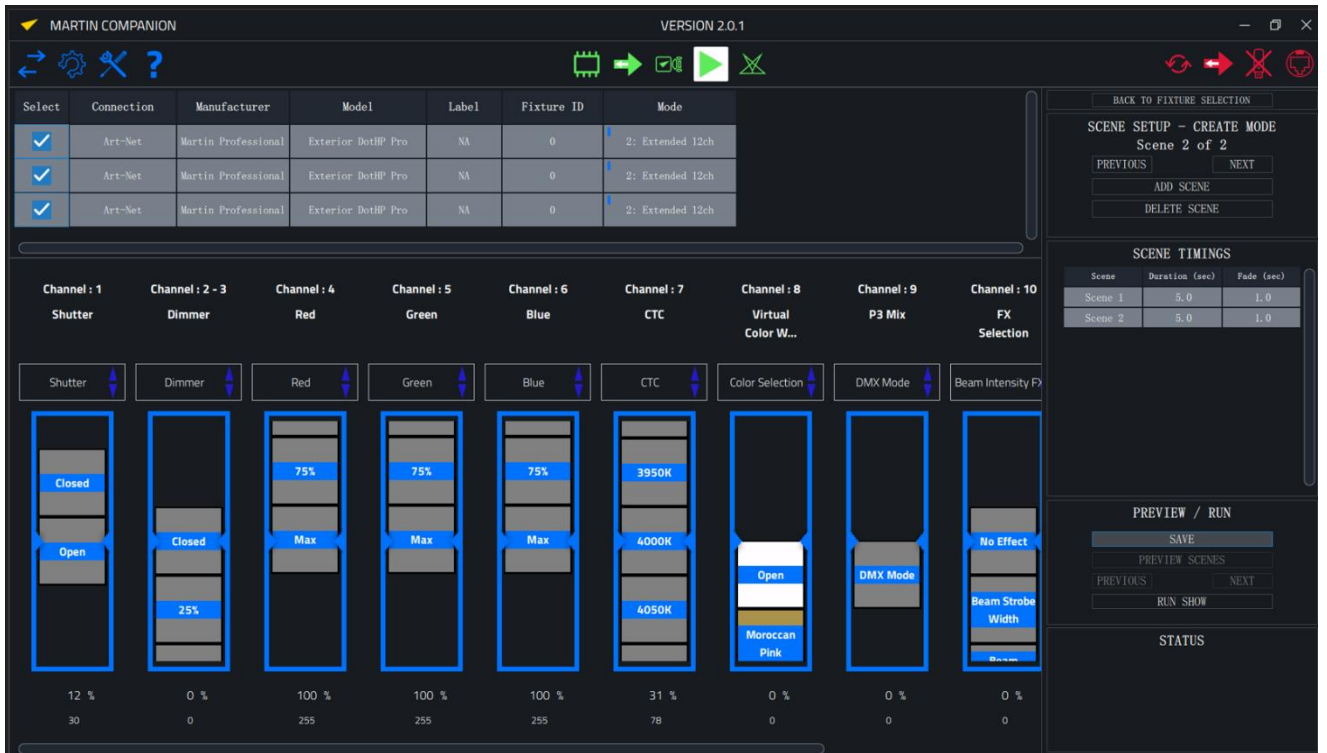

5. Click on **PREVIEW SCENES** to see the scenes that you have created:

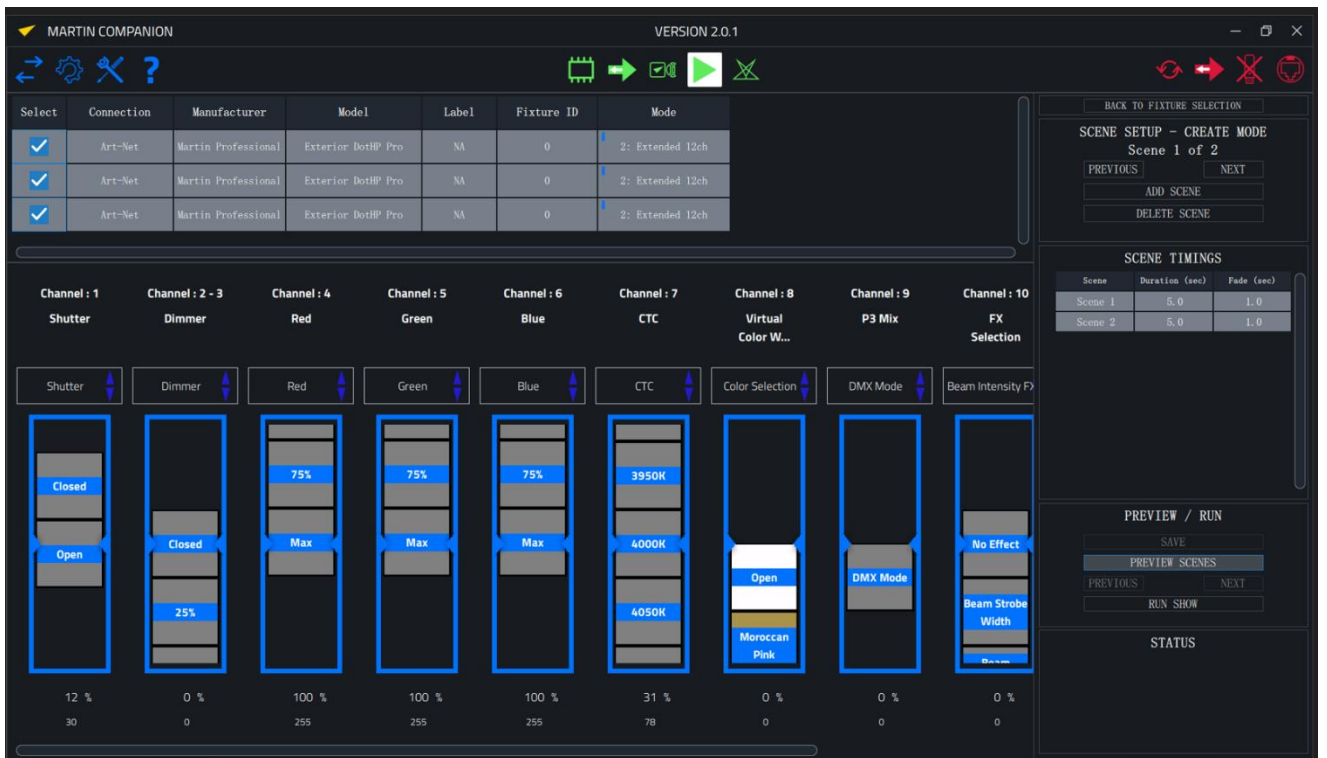

6. Click on **STOP** to stop previewing the scenes:

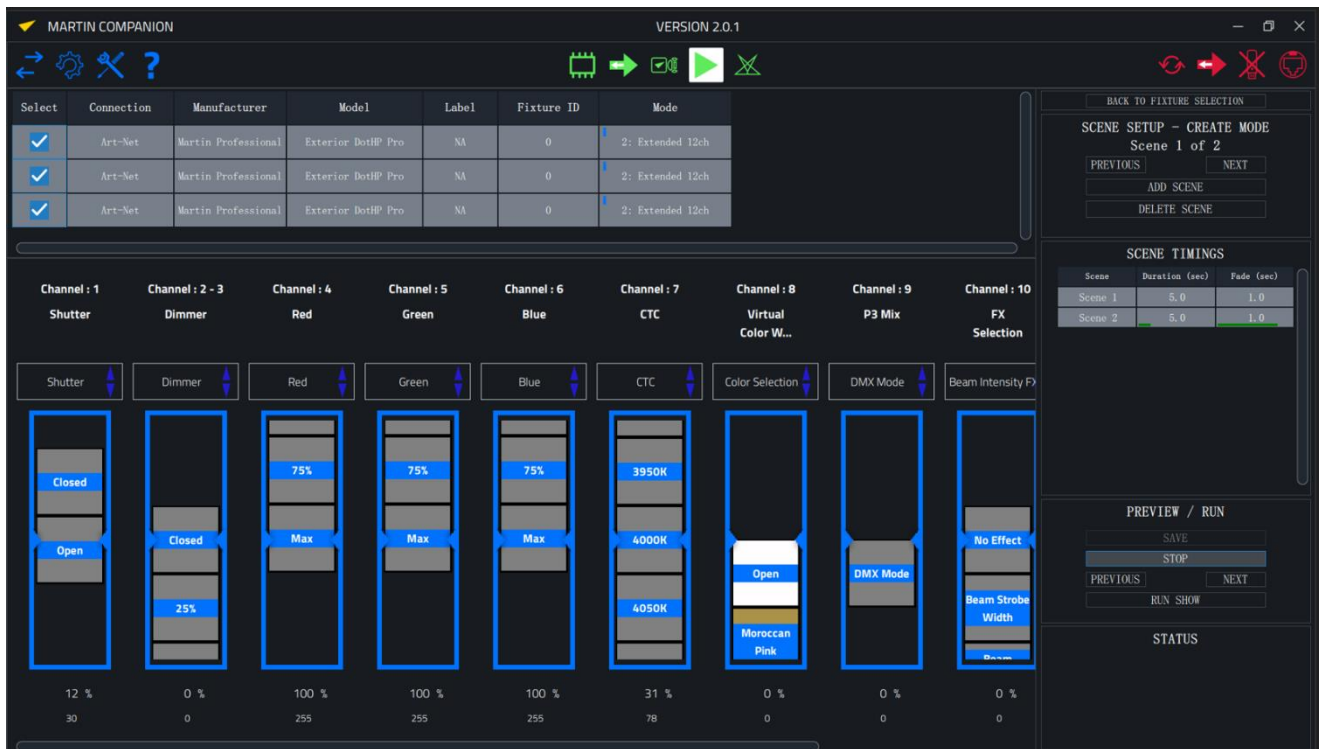

7. Click on **RUN SHOW** to run the standalone show:



Synchronized standalone operation

All Dots programmed together for standalone operation will synchronize the playback of their standalone scenes. Dots need to be connected to each other using their hybrid power and data cables (but not to a DMX controller) to allow this synchronization to happen. The synchronization makes sure that all Dots switch to the same scene number with the same duration and fade time. But each Dot can have a different lighting effect programmed into it for each scene number.

Note that Martin Companion automatically assigns one Dot as the standalone *host*, and all the others as *clients*. The host fixture only tells the client Dots to “go to scene X with fade time Y”. The lighting effect that each Dot uses in a specific scene is stored inside each Dot individually. Again, not all Dots have to show the same lighting effect in each scene. Only the duration and fade times are synchronized.

Operating the Exterior Dot-HP Pro



Warning! Read the Safety and Installation Manual that is included at the end of this User Manual, paying particular attention to the Safety Precautions section, before operating the Exterior Dot-HP Pro.

Note that the output of LEDs, like all light sources, changes gradually over many thousands of hours of use. If you require products to perform to very precise color specifications, you may eventually need to make small readjustments at the lighting controller.

Test sequences and fixture status

The Exterior Dot-HP Pro Series Safety and Installation Manual that is included at the end of this User Manual contains information on displaying fixture status codes and running test sequences that you may find useful before starting operation.

Controlling via DMX

Once you have set up DMX modes and DMX addresses via RDM, you can control Dots using the DMX controller that is connected to the installation.

See the 'DMX protocols' section at the end of this manual for details of the control options available.

Identifying fixtures in the installation

To help with programming scenes and controlling the installation, it is possible to send an RDM command that causes a Dot to flash a signal so that you can identify it. To identify a Dot:

1. Black out all Dots if you have been using them.
2. If you are using RDM, send an IDENTIFY DEVICE unicast command to an individual Dot in the installation. The Dot will respond by flashing white, letting you identify it.
3. If you are using Martin Companion, enable the "Identify" button in the toolbar. Any Dot (or Dots) that you select will immediately identify itself. With "Identify" enabled, you can also use the arrow keys to navigate through the list of Dots – each Dot in the list will flash as soon as you reach it.

Pixel layout

The Exterior Dot-HP Pro pixel layout is shown below:

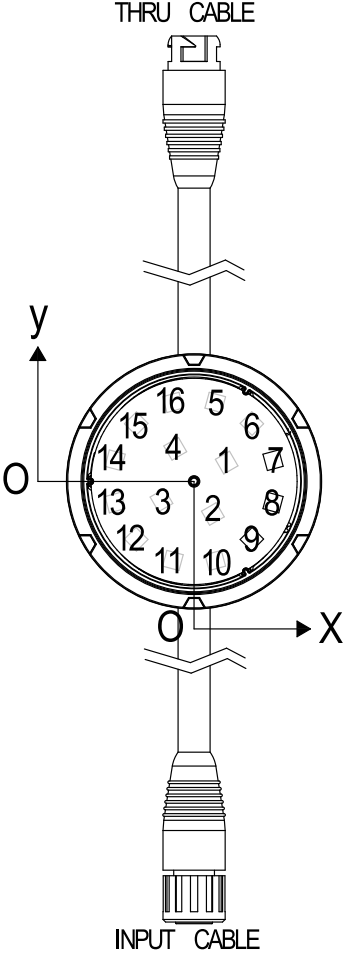

DMX protocols

The Exterior Dot-HP Pro has five DMX control modes.

Standard Mode

Standard DMX Mode gives 16-bit dimming, RGB color control and White color temperature control.

Channel	Resolution	Value	Function	Fade	Default Value
1, 2	16-bit	0-65535	Dimmer Closed → Open	Fade	0
3	8-bit	0-255	Red 0 → 100%	Fade	255
4	8-bit	0-255	Green 0 → 100%	Fade	255
5	8-bit	0-255	Blue 0 → 100%	Fade	255
6	8-bit	0-34 35 36 ... 78 ... 128 ... 255	CTC (Color Temperature Control) 1800 K to 12850 K in 50 K steps 1800 K 1850 K 1900 K ... 4000 K ... 6500 K ... 12850 K	Fade	78

Tint defaults to neutral but can be changed using RDM.

Extended Mode

Extended DMX Mode gives a Shutter/strobe channel, 16-bit dimming, RGB color control and White color temperature control. It also gives a virtual color wheel with 94 Lee-referenced colors, it lets you select and crossfade between DMX and P3 control and it gives access to a range of pre-programmed FX. Fixtures are set to this mode by default.

Channel	Resolution	Value	Function	Fade	Default Value
1	8-bit	0-19 20-49 50-200 201-210 211-255	Strobe/Shutter Shutter closed Shutter open Strobe (slow → fast) Shutter open Random strobe (slow → fast)	Snap	30
2, 3	16-bit	0-65535	Dimmer Closed → Open	Fade	0
4	8-bit	0-255	Red 0 → 100%	Fade	255
5	8-bit	0-255	Green 0 → 100%	Fade	255
6	8-bit	0-255	Blue 0 → 100%	Fade	255

Channel	Resolution	Value	Function	Fade	Default Value
7	8-bit	0-34	CTC (Color Temperature Control) <i>1800 K to 12850 K in 50 K steps</i>	Fade	78
		35	1800 K		
		36	1850 K		
		...	1900 K		
		78	...		
		...	4000 K		
		128	...		
		...	6500 K		
		255	...		
		255	12850 K		
8	8-bit	0-10	Virtual color wheel Open		
		11-12	Solid colors Moroccan Pink (LEE 790)		
		13-14	Pink (LEE 157)		
		15-16	Special Rose Pink (LEE 332)		
		17-18	Follies Pink (LEE 328)		
		19-20	Fuchsia Pink (LEE 345)		
		21-22	Surprise Pink (LEE 194)		
		23-24	Congo Blue (LEE 181)		
		25-26	Tokyo Blue (LEE 071)		
		27-28	Deep Blue (LEE 120)		
		29-30	Just Blue (LEE 079)		
		31-32	Medium Blue (LEE 132)		
		33-34	Double CT Blue (LEE 200)		
		35-36	Slate Blue (LEE 161)		
		37-38	Full CT Blue (LEE 201)		
		39-40	Half CT Blue (LEE 202)		
		41-42	Steel Blue (LEE 117)		
		43-44	Lighter Blue (LEE 353)		
		45-46	Light Blue (LEE 118)		
		47-48	Medium Blue Green (LEE 116)		
		49-50	Primary Green (LEE 139)		
		51-52	Moss Green (LEE 089)		
		53-54	Fern Green (LEE 122)		
		55-56	Jas Green (LEE 738)		
		57-58	Lime Green (LEE 088)		
		59-60	Spring Yellow (LEE 100)		
		61-62	Deep Amber (LEE 104)		
		63-64	Chrome Orange (LEE 179)		
		65-66	Orange (LEE 105)		
		67-68	Gold Amber (LEE 021)		
		69-70	Millennium Gold (LEE 778)		
		71-72	Deep Golden Amber (LEE 135)		
		73-74	Flame Red (LEE 164)		
		75-76	Red Magenta (LEE 113)		
		77-78	Medium Lavender (LEE 343)		
		79-80	Pure White (White LEDs only)		
		81-82	Pure Red (Red LEDs only)		
		83-84	Pure Yellow (Red + Green LEDs only)		
		85-86	Pure Green (Green LEDs only)		
		87-88	Pure Cyan (Green + Blue LEDs only)		
89-90	Pure Blue (Blue LEDs only)				

Channel	Resolution	Value	Function	Fade	Default Value
8 contd.	8-bit	91-92 93-94 95-96 97-98 99-100 101-102 103-104 105-106 107 - 190 191 - 214 215 - 219 220 - 243 244 - 247 248 - 251 252 - 255	Dark Green (LEE 124) Pure Magenta (Blue + Red LEDs only) Peacock Blue (LEE 115) Dark Lavender (LEE 180) Double CT Orange (LEE 287) Full CT Orange (LEE 204) Half CT Orange (LEE 205) Deep Straw (LEE 015) No function Continuous rotation CW, Fast → Slow Stop (wheel stops at current color) CCW, Slow → Fast Random slots 244 - 247 Fast 248 - 251 Medium 252 - 255 Slow	Snap	0
9	8-bit	0 - 26 27 - 228 229 - 255	P3 Mix DMX Mode Color of LEDs is fully controlled by DMX channels, P3 pixel data is ignored Mix Mode At the bottom of the range (27), the output is pure DMX-controlled. In-between there is a crossfade between DMX and P3 Pixels At the top of the range (228), the output is pure P3 pixel-controlled Video Mode Color of LEDs is controlled by P3 pixels multiplied with DMX channels. This allows the DMX channels to "color" the P3 pixel data	Snap	0
10	8-bit	0 - 255	FX Select (see 'FX list' on page 29) FX selection 1 -255	Snap	0
11	8-bit	0 - 126 127 - 128 129 - 255	FX Adjust Reversed Fast → Slow Stop Forwards Slow → Fast	Fade	128
12	8-bit	0 1 - 35 36 37 - 100 101 - 120 121 - 140 141 - 255	FX Synchronization No sync Dot offset (Shift from 10 – 350 degrees) Synchronized No function Random start Random duration No function	Snap	36

Direct Mode

Channel	Resolution	Value	Function	Fade	Default Value
1	8-bit	0-255	Red 0 → 100%	Fade	0
2	8-bit	0 -255	Green 0 → 100%	Fade	0
3	8-bit	0-255	Blue 0 → 100%	Fade	0
4	8-bit	0-255	White 0 → 100%	Fade	0

RGB Mode

Channel	Resolution	Value	Function	Fade	Default Value
1	8-bit	0-255	Red 0 → 100%	Fade	0
2	8-bit	0 -255	Green 0 → 100%	Fade	0
3	8-bit	0-255	Blue 0 → 100%	Fade	0

CTC defaults to 4000 K but can be changed using RDM.

Tint defaults to neutral but can be changed using RDM.

PixelMap Mode

Channel	Resolution	Value	Function	Fade	Default Value
1	8-bit	0-255	Red, pixel 1 0 → 100%	Fade	0
2	8-bit	0 -255	Green, pixel 1 0 → 100%	Fade	0
3	8-bit	0-255	Blue, pixel 1 0 → 100%	Fade	0
4 ... 45	8-bit	0-255	RGB control of pixels 3 to 15	Fade	0
46	8-bit	0-255	Red, pixel 16 0 → 100%	Fade	0
47	8-bit	0-255	Green, pixel 16 0 → 100%	Fade	0
48	8-bit	0-255	Blue, pixel 16 0 → 100%	Fade	0

CTC defaults to 4000 K but can be changed using RDM.

Tint defaults to neutral but can be changed using RDM.

FX overview

The Exterior Dot-Pro offers a range of FX (pre-programmed macros) as outlined below:

FX type	Description	Number of effects	Color Adjustments	FX Adjust (speed/direction)	FX Synchronization (offsetting)
Intensity	Intensity effects on each Dot	13	<ul style="list-style-type: none"> • RGB or P3 sets foreground color • Virtual color wheel sets background color 	X	X
Pixel Intensity	Intensity effects on individual pixels in the Dot	80	<ul style="list-style-type: none"> • RGB or P3 sets foreground color • Virtual color wheel sets background color 	X	X
Overlay	Overlay effects on individual pixels in the Dot	68	<ul style="list-style-type: none"> • Overlay color white or set by virtual color wheel • Overlaid on normal output by RGB or P3 	X	X
Color Effect	Color effects on individual pixels in the Dot	44	<ul style="list-style-type: none"> • Predefined color effects • Ignores P3 or DMX colors 	X	X
Color Modifier	Color modification on individual pixels in the Dot	13	<ul style="list-style-type: none"> • Takes DMX or P3 colors and modifies them 	Degree of color offset	X
Video SloMo	Output of LEDs is average of last x frames Same effect on all Exterior Dot-HP Pros	1		Number of frames to average	No function

Pixel Masks	Mask out pixels according to Pixel Mask table* Individual control of each pixel	256	<ul style="list-style-type: none"> • RGB or P3 sets color for “On pixels” • Color wheel sets color for “OFF pixels” 	Selects Pixel mask combination	No function
Color Looks	256 predefined color looks Individual control of each pixel	256	<ul style="list-style-type: none"> • Predefined color effects • Ignores P3 or DMX colors 	Selects Color mask combination	No function

FX list

The table below lists the FX patterns available in “Extended” DMX mode.

Type	DMX	Name	Description
	0	No FX	
Intensity All	1	Strobe Width	When strobe is activated on channel 1, and this effect is active, the FX speed channel controls the width of the strobe pulses / on time (128 = standard strobe pulse width, 0-127 = shorter strobe pulse width, 129-255 = longer strobe pulse width)
	2	Blackout Strobe	Full Blackout Strobe
	3	2x Strobe	Full 2x Strobe
	4	3x Strobe	Full 3x Strobe
	5	4x Strobe	Full 4x Strobe
	6	Up, Down, Flash	Full Up-Down-Flash
	7	Up, Down, Flash Second Color	Full Up-Down-Flash Second Color
	8	Up, Flash, Down, Flash	Full Up-Flash-Down-Flash
	9	Up, Flash, Down, Flash Second Color	Full Up-Flash-Down-Flash Second Color
	10	Random Levels	Full Random Levels
	11	Movie Flicker	Full
	12	Atomic Lighting	Full
	13	Thunderstorm	Full
	14 ... 18	No FX	
Pixel Intensity	19	Pixel Killer Static	LEDs Pixel Killer
	20	Sparkle Stars	Sparkling stars overlay (random twinkling of individual pixels)
	21	Sparkle Stars Heavy	Same as Sparkle Stars but with more LEDs active at same time
	22	Lightning Flashes Random	LEDs flashing random like lightning
	23	Lightning Flashes Random Heavy	More LEDs flashing random like lightning
	24	Lightning Flashes Linear	LEDs flashing linear like lightning
	25	Lightning Flashes Linear Heavy	LEDs flashing linear like lightning, heavy
	26	Fiberoptic	Fiber optic effect
	27	Noise	LEDs Noise Overlay
	28	Build Up/Down Step	Pixels turn on/off in order without crossfade
	29	Build Up/Down Fade	Pixels turn on/off in order with crossfade
	30	Build Up/Down Random Step	Pixels turn on/off in random order without crossfade

Pixel Intensity	31	Build Up/Down Random Fade	Pixels turn on/off in random order with crossfade
	32	Random 5% Step	Random pixel chase snap with 5% of pixels on
	33	Random 5% Fade	Random pixel chase crossfade with 5% of pixels on
	34	Random 10% Step	Random pixel chase snap with 10% of pixels on
	35	Random 10% Fade	Random pixel chase crossfade with 10% of pixels on
	36	Random 20% Step	Random pixel chase snap with 20% of pixels on
	37	Random 20% Fade	Random pixel chase crossfade with 20% of pixels on
	38	Random 40% Step	Random pixel chase snap with 40% of pixels on
	39	Random 40% Fade	Random pixel chase crossfade with 40% of pixels on
	40	Random 80% Step	Random pixel chase snap with 80% of pixels on
	41	Random 80% Fade	Random pixel chase crossfade with 80% of pixels on
	42	Split Static	Split Dot pixels into two halves, use FX Speed channel to index (rotate to a specific angle) the split line
	43	Split Bounce Step	Split Dot pixels into two halves, use FX Speed channel to bounce the split line continuously
	44	Split Bounce Fade	Split Dot pixels into two halves, use FX Speed channel to bounce the split line continuously with crossfading
	45	Odd-Even 1-2 Step	Odd pixels vs. even pixels with snap
	46	Odd-Even 1-2 Fade	Odd pixels vs. even pixels with crossfade
	47	Radar Spin snap	Radar line spinning with snap
	48	Radar Spin fade	Radar line spinning with crossfade
	49	Line Spin Step	Diagonal line spinning with snap
	50	Line Spin Step	Diagonal line spinning with crossfade
	51	Slice Pie 1 Step	Slice of pie spinning with snap 1
	52	Slice Pie 1 Fade	Slice of pie spinning with crossfade 1
	53	Slice Pie 2 Step	Slice of pie spinning with snap 2
	54	Slice Pie 2 Fade	Slice of pie spinning with crossfade 2
	55	Slice Pie 3 Step	Slice of pie spinning with snap 3
	56	Slice Pie 3 Fade	Slice of pie spinning with crossfade 3
	57	Random Slice Pie Step	Random slice of pie with snap
	58	Random Slice Pie Fade	Random slice of pie with crossfade
	59	Snake 1 LED Step	1 pixel running around with snap
	60	Snake 1 LED Fade	1 pixel running around with crossfade
	61	Snake 2 LED Step	2 pixels running around with snap

Pixel Intensity	62	Snake 2 LED Fade	2 pixels running around with crossfade
	63	Snake 4 LED Step	4 pixels running around with snap
	64	Snake 4 LED Fade	4 pixels running around with crossfade
	65	Snake 8 LED Step	8 pixels running around with snap
	66	Snake 8 LED Fade	8 pixels running around with crossfade
	67	Vertical Line Step	Vertical line chase with snap
	68	Vertical Line Fade	Vertical line chase with crossfade
	69	Vertical Line Bounce Step	Vertical line bounce with snap
	70	Vertical Line Bounce Fade	Vertical line bounce with crossfade
	71	Horizontal Line Step	Horizontal line chase with snap
	72	Horizontal Line Fade	Horizontal line chase with crossfade
	73	Horizontal Line Bounce Step	Horizontal line bounce with snap
	74	Horizontal Line Bounce Fade	Horizontal line bounce with crossfade
	75	Vertical + Horizontal Line Bounce Step	Vertical + horizontal line bounce with snap
	76	Vertical + Horizontal Line Bounce Fade	Vertical + horizontal line bounce with crossfade
	77	Gradient Fade 30 deg	Similar to Pixel mask 176, but moving over the pixels
	78	Gradient Fade 75 deg	Similar to Pixel mask 183, but moving over the pixels
	79	Gradient Fade 120 deg	Similar to Pixel mask 182, but moving over the pixels
	80	Gradient Fade 165 deg	Similar to Pixel mask 181, but moving over the pixels
	81	Gradient Fade 210 deg	Similar to Pixel mask 180, but moving over the pixels
	82	Gradient Fade 255 deg	Similar to Pixel mask 179, but moving over the pixels
	83	Gradient Fade 300 deg	Similar to Pixel mask 178, but moving over the pixels
	84	Gradient Fade 345 deg	Similar to Pixel mask 177, but moving over the pixels
	85	Gradient Fade Center 30 deg	Similar to Pixel mask 186, but moving over the pixels
	86	Gradient Fade Center 75 deg	Similar to Pixel mask 185, but moving over the pixels
	87	Gradient Fade Center 120 deg	Similar to Pixel mask 184, but moving over the pixels
	88	Gradient Fade Center 165 deg	Similar to Pixel mask 187, but moving over the pixels
	89	Nightrider	Nightrider (classic red pixel chase effect)
90	Starfield	Regular	
91	Starfield Heavy	Heavy	

Pixel Intensity	92	Snowflakes	Regular
	93	Snowflakes Heavy	Heavy
	94	Rain	Regular
	95	Rain Heavy	Heavy
	96	Ring Step	Intensity rings with snap
	97	Ring Fade	Intensity rings with fade
	98	Waterdrop	Intensity ripple from center to outside
	99 ... 103	No FX	
Overlays	104	Overlay Sparkle Stars	Random twinkling of individual pixels
	105	Overlay Sparkle Stars Heavy	Same as Sparkle Stars but with more pixels
	106	Overlay Lightning Flashes Random	Lightning flash simulation
	107	Overlay Lightning Flashes Random Heavy	Lightning flash simulation with more pixels
	108	Overlay Lightning Flashes Left-Right	Linear lightning flash simulation
	109	Overlay Lightning Flashes Top-Bottom	Linear lightning flash simulation
	110	Overlay Fiberoptic	Fiber optic effect
	111	Overlay Noise	Pixel noise overlay
	112	Overlay Random 1 Step	Random pixel chase snaps with 1 pixel always on
	113	Overlay Random 1 Fade	Random pixel chase crossfades with 1 pixel always on
	114	Overlay Random 2 Step	Random pixel chase snaps with 2 pixels always on
	115	Overlay Random 2 Fade	Random pixel chase crossfades with 2 pixels always on
	116	Overlay Random 4 Step	Random pixel chase snaps with 4 pixels always on
	117	Overlay Random 4 Fade	Random pixel chase crossfades with 4 pixels always on
	118	Overlay Random 8 Step	Random pixel chase snaps with 8 pixels always on
	119	Overlay Random 8 Fade	Random pixel chase crossfades with 8 pixels always on
	120	Overlay Random 12 Step	Random pixel chase snaps with 12 pixels always on
121	Overlay Random 12 Fade	Random pixel chase crossfades with 12 pixels always on	
122	Overlay Radar Spin Step	Radar line spinning with snap	
123	Overlay Radar Spin Fader	Radar line spinning with crossfade	
124	Overlay Line Spin Step	Diagonal line spinning with snap	

Overlays	125	Overlay Line Spin Fade	Diagonal line spinning with crossfade
	126	Overlay Slice Pie 1 Step	Slice of pie spinning with snap 1
	127	Overlay Slice Pie 1 Fade	Slice of pie spinning with crossfade 1
	128	Overlay Slice Pie 2 Step	Slice of pie spinning with snap 2
	129	Overlay Slice Pie 2 Fade	Slice of pie spinning with crossfade 2
	130	Overlay Slice Pie 3 Step	Slice of pie spinning with snap 3
	131	Overlay Slice Pie 3 Fade	Slice of pie spinning with crossfade 3
	132	Overlay Random Slice Pie Step	Random slice of pie with snap
	133	Overlay Random Slice Pie Fade	Random slice of pie with crossfade
	134	Overlay Snake 1 LED Step	1 pixel running around with snap
	135	Overlay Snake 1 LED Fade	1 pixel running around with crossfade
	136	Overlay Snake 2 LED Step	2 pixels running around with snap
	137	Overlay Snake 2 LED Fade	2 pixels running around with crossfade
	138	Overlay Snake 4 LED Step	4 pixels running around with snap
	139	Overlay Snake 4 LED Fade	4 pixels running around with crossfade
	140	Overlay Snake 8 LED Step	8 pixels running around with snap
	141	Overlay Snake 8 LED Fade	8 pixels running around with crossfade
	142	Overlay Vertical Line Step	Vertical line chase with snap
	143	Overlay Vertical Line Fade	Vertical line chase with crossfade
	144	Overlay Vertical Line Bounce Step	Vertical line bounce with snap
	145	Overlay Vertical Line Bounce Fade	Vertical line bounce with crossfade
	146	Overlay Horizontal Line Step	Horizontal line chase with snap
	147	Overlay Horizontal Line Fade	Horizontal line chase with crossfade
	148	Overlay Horizontal Line Bounce Step	Horizontal line bounce with snap
	149	Overlay Horizontal Line Bounce Fade	Horizontal line bounce with crossfade
	150	Overlay Vertical + Horizontal Line Bounce Step	Horizontal and vertical line bounce with snap
	151	Overlay Vertical + Horizontal Line Bounce Fade	Horizontal and vertical line bounce with crossfade
	152	Overlay Gradient Fade 30 deg	Similar to Pixel mask 176, but moving over the pixels
153	Overlay Gradient Fade 75 deg	Similar to Pixel mask 183, but moving over the pixels	
154	Overlay Gradient Fade 120 deg	Similar to Pixel mask 182, but moving over the pixels	

Overlays	155	Overlay Gradient Fade 165 deg	Similar to Pixel mask 181, but moving over the pixels
	156	Overlay Gradient Fade 210 deg	Similar to Pixel mask 180, but moving over the pixels
	157	Overlay Gradient Fade 255 deg	Similar to Pixel mask 179, but moving over the pixels
	158	Overlay Gradient Fade 300 deg	Similar to Pixel mask 178, but moving over the pixels
	159	Overlay Gradient Fade 345 deg	Similar to Pixel mask 177, but moving over the pixels
	160	Overlay Gradient Fade Center 30 deg	Similar to Pixel mask 186, but moving over the pixels
	161	Overlay Gradient Fade Center 75 deg	Similar to Pixel mask 185, but moving over the pixels
	162	Overlay Gradient Fade Center 120 deg	Similar to Pixel mask 184, but moving over the pixels
	163	Overlay Gradient Fade Center 165 deg	Similar to Pixel mask 187, but moving over the pixels
	164	Overlay Nightrider	Heavy
	165	Overlay Starfield	Regular
	166	Overlay Starfield Heavy	Heavy
	167	Overlay Snowflakes	Regular
	168	Overlay Snowflakes Heavy	Heavy
	169	Overlay Rain	Regular
	170	Overlay Rain Heavy	Heavy
	171	Overlay Waterdrop	Intensity ripple from center to outside
	172 ... 178	No FX	
Color Pixels	179	Rainbow LEDs Step	Rainbow across the pixels (in pixel order) with snap
	180	Rainbow LEDs Fade	Rainbow across the pixels (in pixel order) with crossfade
	181	Random Rainbow LEDs Step	Random rainbow across the pixels with snap
	182	Random Rainbow LEDs Fade	Random rainbow across the pixels with crossfade
	183	Red-Yellow LEDs Step	Red-Yellow variations across the pixels (in pixel order) with snap
	184	Red-Yellow LEDs Fade	Red-Yellow variations across the pixels (in pixel order) with crossfade
	185	Random Red-Yellow LEDs Step	Red-Yellow variations across the LEDs with snap
	186	Random Red-Yellow LEDs Fade	Red-Yellow variations across the LEDs with crossfade
	187	Yellow-Green LEDs Step	Yellow-Green variations across the LEDs (in pixel order) with snap

Color Pixels	188	Yellow-Green LEDs Fade	Yellow-Green variations across the LEDs (in pixel order) with crossfade
	189	Random Yellow-Green LEDs Step	Yellow-Green variations across the LEDs with snap
	190	Random Yellow-Green LEDs Fade	Yellow-Green variations across the LEDs with crossfade
	191	Green-Cyan LEDs Step	Green-Cyan variations across the LEDs (in pixel order) with snap
	192	Green-Cyan LEDs Fade	Green-Cyan variations across the LEDs (in pixel order) with crossfade
	193	Random Green-Cyan LEDs Step	Green-Cyan variations across the LEDs with snap
	194	Random Green-Cyan LEDs Fade	Green-Cyan variations across the LEDs with crossfade
	195	Cyan-Blue LEDs Step	Cyan-Blue variations across the LEDs (in pixel order) with snap
	196	Cyan-Blue LEDs Fade	Cyan-Blue variations across the LEDs (in pixel order) with crossfade
	197	Random Cyan-Blue LEDs Step	Cyan-Blue variations across the LEDs with snap
	198	Random Cyan-Blue LEDs Fade	Cyan-Blue variations across the LEDs with crossfade
	199	Blue-Magenta LEDs Step	Blue-Magenta variations across the LEDs (in pixel order) with snap
	200	Blue-Magenta LEDs Fade	Blue-Magenta variations across the LEDs (in pixel order) with crossfade
	201	Random Blue-Magenta LEDs Step	Blue-Magenta variations across the LEDs with snap
	202	Random Blue-Magenta LEDs Fade	Blue-Magenta variations across the LEDs with crossfade
	203	Magenta-Red LEDs Step	Magenta-Red variations across the LEDs (in pixel order) with snap
	204	Magenta-Red LEDs Fade	Magenta-Red variations across the LEDs (in pixel order) with crossfade
	205	Random Magenta-Red LEDs Step	Magenta-Red variations across the LEDs with snap
	206	Random Magenta-Red LEDs Fade	Magenta-Red variations across the LEDs with crossfade
	207	Red White Blue Step	Full with snap
	208	Red White Blue Fade	Full with crossfade
	209	Fire	Pixels
	210	Water	Pixels
	211	Swimming pool	Pixels
	212	Ice	Pixels
213	Hot and cold	Pixels	
214	Warm and fuzzy	Pixels	
215	Silver and gold	Pixels	

Color Pixels	216	Gold and silver	Pixels	
	217	Electric arc	Pixels	
	218	Plasma	Pixels	
	219	Police Car 1		
	220	Police Car 2		
	221	Police Car 3		
	222	Welding	Welding flashes	
	223 ... 227	No FX		
Color Modifier	228	Spectrum Shifter Static	Shift color of each individual LED	
	229	Spectrum Shifter Step	As spectrum shifter static, but random stepping thru random levels of shift (FX speed sets max. shift - Speed fixed)	
	230	Spectrum Shifter Fade	As spectrum shifter static, but random fading thru random levels of shift (FX speed sets max. shift - Speed fixed)	
	231	Pixel Spectrum Shifter Static	LED 1: no color change / LED 32/100: maximum color change (as set by FX speed channel)	
	232	Pixel Spectrum Shifter Step	As pixel spectrum shifter static, but effect steps thru the pixels in order (FX speed sets max. shift - Speed fixed)	
	233	Pixel Spectrum Shifter Fade	As pixel spectrum shifter static, but effect fades thru the pixels in order (FX speed sets max. shift - Speed fixed)	
	234	Pixel Spectrum Shifter Random Static	As pixel spectrum shifter static, but random pixel order	
	235	Pixel Spectrum Shifter Random Step	As pixel spectrum shifter step, but random pixel order (FX speed sets max. shift - Speed fixed)	
	236	Pixel Spectrum Shifter Random Fade	As pixel spectrum shifter fade, but random pixel order (FX speed sets max. shift - Speed fixed)	
	237	Color Toggle Step	Step between color defined by RGB + P3 and Color Wheel	
	238	Color Toggle Fade	Fade between color defined by RGB + P3 and Color Wheel	
	239	Tungsten	RGB input to each LED (from DMX or P3) is translated to intensity only, and LED shows 2700 K white with tungsten dimming effect	
	240	Tungsten Delay	RGB input to each LED (from DMX or P3) is translated to intensity only, and LED shows 2700 K white with tungsten dimming effect including delay	
		241 ... 245	No FX	
	Timing	246	Video Slo-Mo	Output of LEDs is average of last x frames (DMX or P3) – the FX Speed channel sets the number of frames to average
	247 ... 250	No FX		

Special	251	Pixel Masks Static	Value of the FX Speed channel selects which combination of pixels is ON
	252 253	No FX	
Special	254	Color Looks Static	Value of the FX Speed channel selects between 256 predefined looks
	255	No FX	

Exterior Dot-HP Pro

Safety and Installation manual



Martin[®]

Dimensions

Exterior Dot-HP Pro clear front without flange bracket

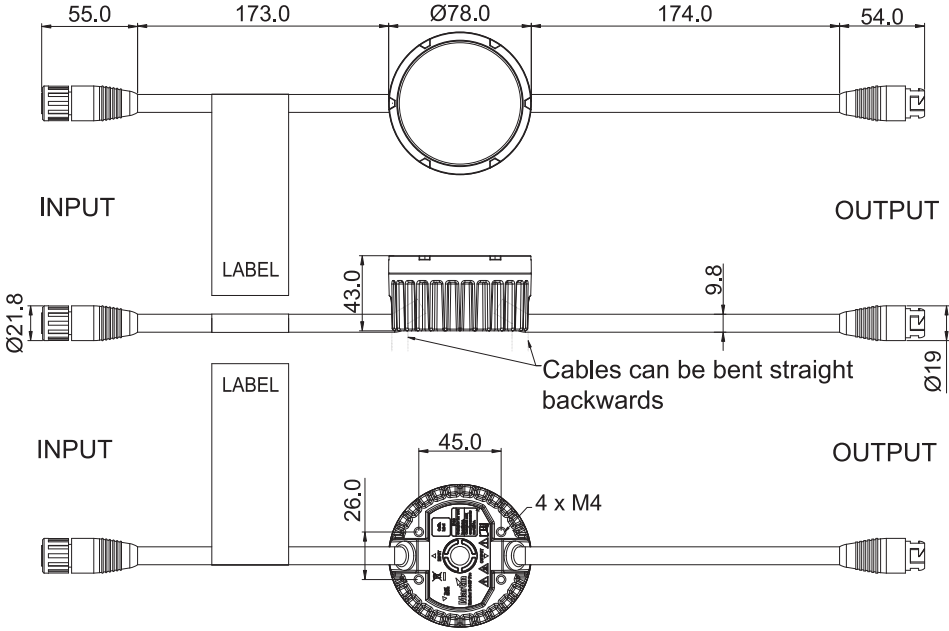

Exterior Dot-HP Pro clear front with flange bracket

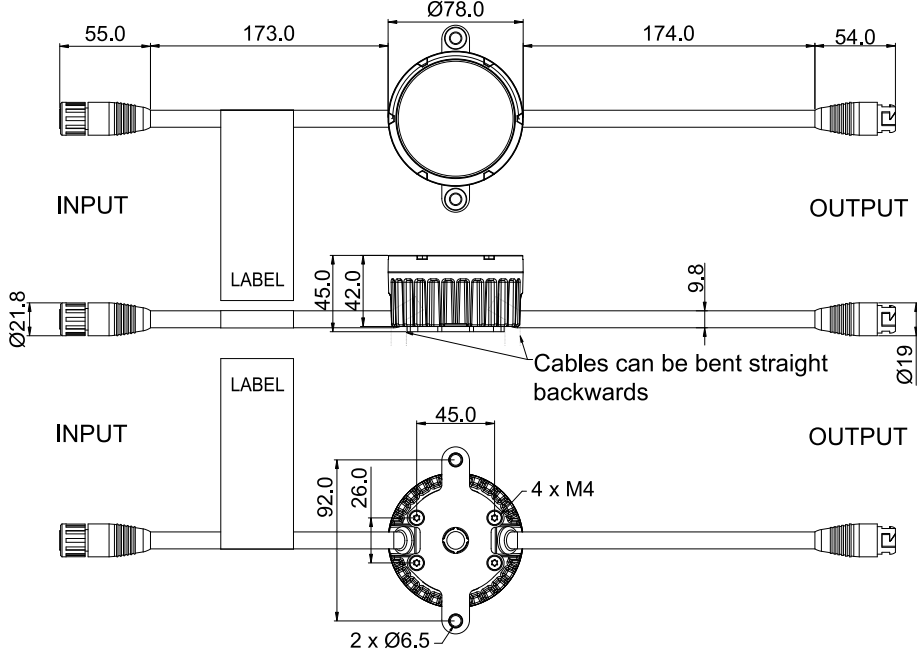

©2025 HARMAN PROFESSIONAL DENMARK ApS. All rights reserved. Features, specifications and appearance are subject to change without notice. HARMAN PROFESSIONAL DENMARK ApS and all affiliated companies disclaim liability for any injury, damage, direct or indirect loss, consequential or economic loss or any other loss occasioned by the use of, inability to use or reliance on the information contained in this document. Martin is a registered trademark of HARMAN PROFESSIONAL DENMARK ApS registered in the United States and/or other countries.

HARMAN PROFESSIONAL DENMARK ApS, Olof Palmes Allé 44, 8200 Aarhus N, Denmark
 HARMAN PROFESSIONAL, INC., 8500 Balboa Blvd., Northridge CA 91325, USA

www.martin.com

Exterior Dot HP-Pro dome front without flange bracket

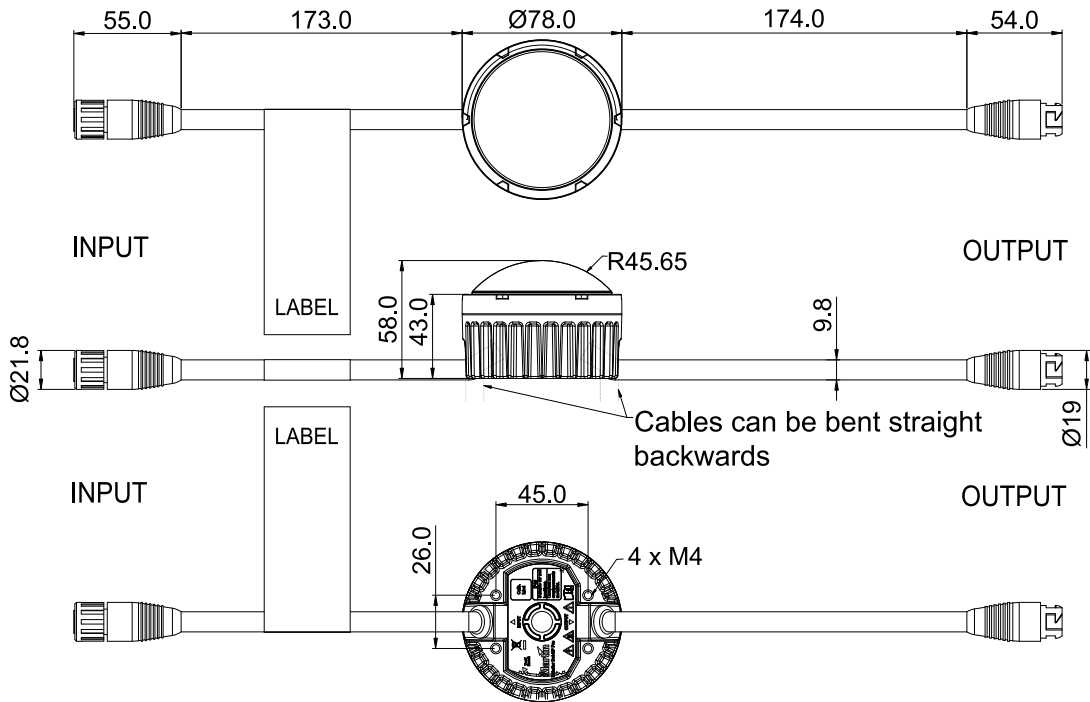

Exterior Dot-HP Pro dome front with flange bracket

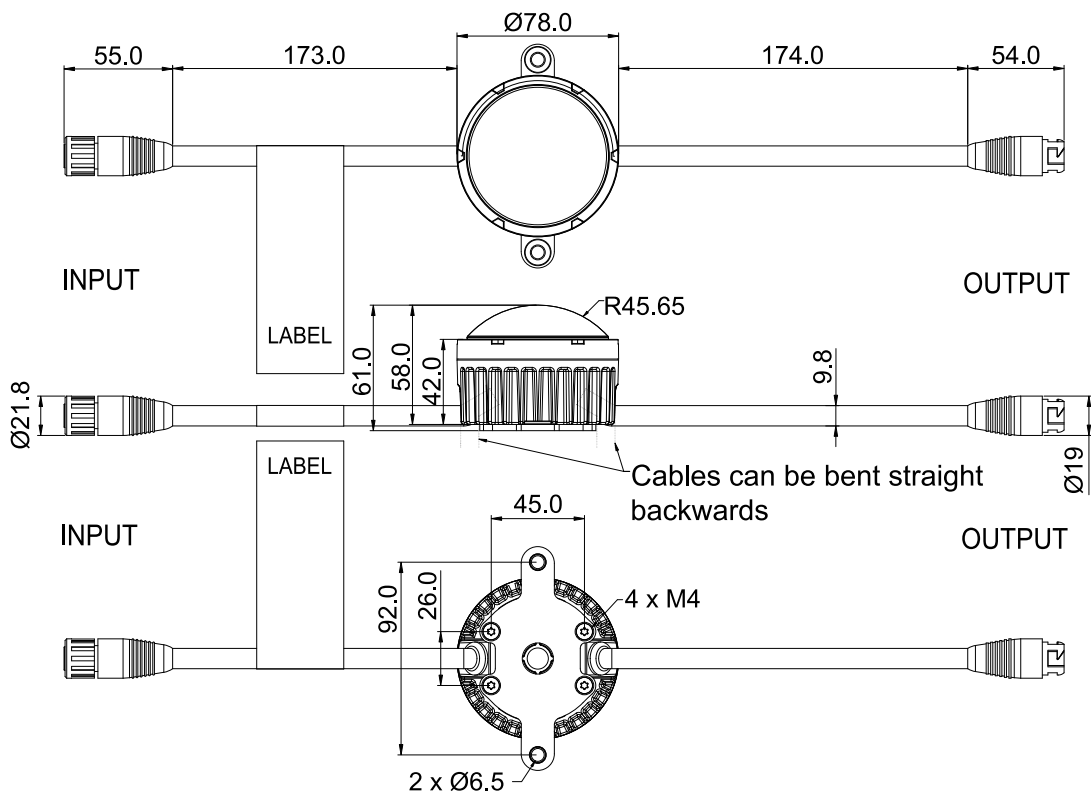

All dimensions are in millimeters

Exterior Dot-HP Pro mounting profile

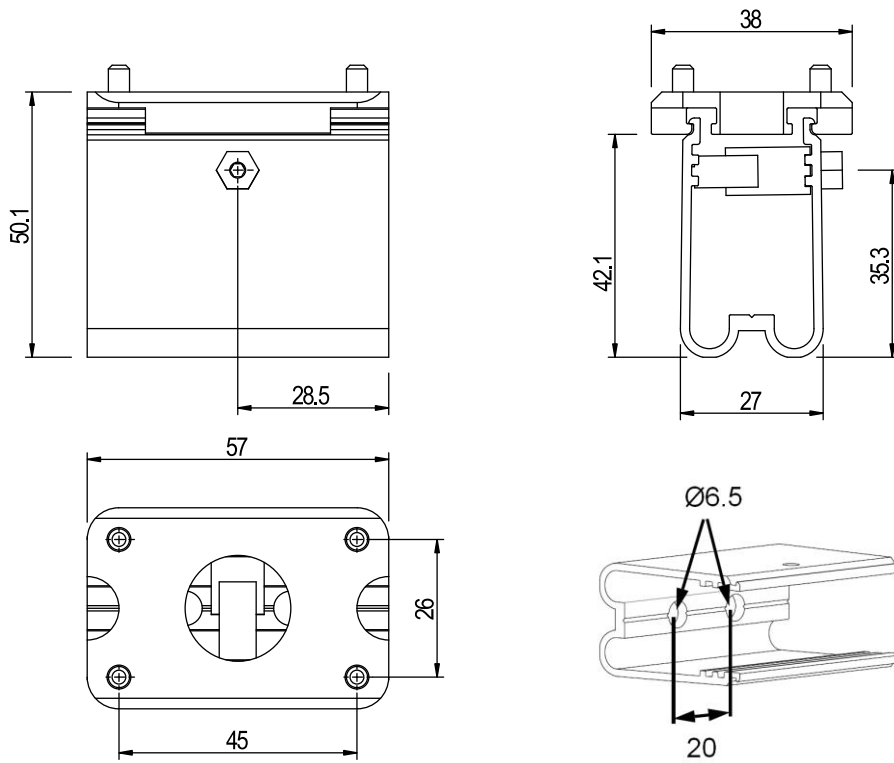

Exterior Dot-HP Pro flange bracket

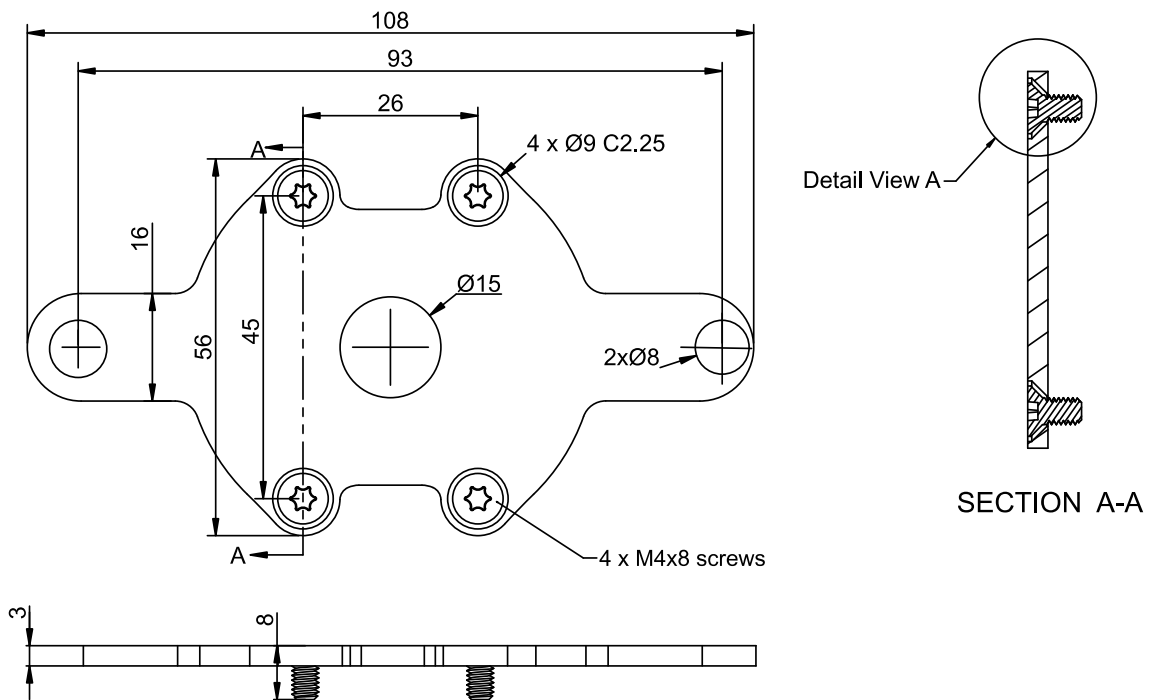

All dimensions are in millimeters.

Table of contents

- Dimensions 2
- Safety information 6
- Precautions to avoid damage 10
- Introduction 12
 - Optional accessories 12
 - Before using the product for the first time 12
- Physical installation 13
 - Location 13
 - Mounting the device 13
- System installation 17
- Testing 19
- Maintenance 20
 - Cleaning 20
 - Pressure relief valve 20
- Specifications and compliance 21

Safety information



WARNING!

Read the safety precautions in this manual before installing, operating or servicing this product.

The following symbols are used to identify important safety information on the product and in this manual:



Warning!

***Safety hazard.
Risk of severe
injury or death.***



Warning!

***Hazardous
voltage. Risk of
lethal or severe
electric shock.***



Warning!

Fire hazard.



Warning!

***Burn hazard.
Hot surface. Do
not touch.***



Warning!

***Intense light
emission.***



Warning!

***See user
documentation.***



Warning! Read this Safety and Installation Manual before installing, powering or servicing the Exterior Dot-HP Pro. Follow the safety precautions given in this manual and in the manuals of all the devices you connect to the product. Observe all warnings given in manuals and printed on devices. Respect all locally applicable laws and regulations. Make sure that everyone who is involved in working on or using the product has read and understood these safety precautions and warnings.



Check the Exterior Dot-HP Pro pages on the Martin® website at www.martin.com and make sure that you have the latest user documentation for the product. Martin user manual revisions are identified at the bottom of page 2. Read the latest revision of the user documentation before installing, operating or servicing the Exterior Dot-HP Pro.

Install, operate and service Martin products only as directed in their manuals, or you may create a safety hazard or cause damage that is not covered by product warranties. Keep this manual for future use.

The Exterior Dot-HP Pro is for professional use and must be installed by a qualified technician. It is not for household use.

The safety and suitability of lifting equipment, installation location, anchoring method, mounting hardware and electrical installation are the responsibility of the installer.

Users may carry out external cleaning and install the flange bracket available from Martin following the instructions and warnings given in this manual, but any service operation not described in this manual or in the Exterior Dot-HP Pro User Manual must be referred to an authorized Martin service agent. The light source contained in the Exterior Dot-HP Pro may be replaced by Martin or an authorized Martin service agent only.

The Exterior Dot-HP Pro is suitable for mounting at any height, including less than 1.2 m (3.9 ft.) and more than 5 m (16.4 ft.) above ground or floor level.

Do not operate the Exterior Dot-HP Pro at an altitude of more than 2000 m (6570 ft.) above sea level.

Technical Support

If you have any questions about how to install or operate the Exterior Dot-HP Pro safely, please contact Harman Professional Technical support.

For technical support in N. America, please contact
HProTechSupportUSA@harman.com
Phone: (844) 776-4899

For technical support outside North America, please contact your national distributor.



Protection from electric shock

Read and respect the directions given in the user documentation of all the devices that you intend to connect to the Exterior Dot-HP Pro, particularly the instructions, warnings and limits that apply to:

- system layout,
- connections to other devices,
- specified cables,
- maximum cable lengths, and
- maximum number of devices that can be connected.

Use only the cables specified in this manual and on the Martin website at www.martin.com to interconnect devices in the installation. If the specified cables are not long enough for an intended cable run, consult Martin for assistance in finding or creating a safe alternative solution.

Provide a means of locking out AC mains power so that power to the installation can be shut down and made impossible to reapply, even accidentally, during work on the installation.

Support the weight of cable runs. Do not allow a length of cable to hang from a cable gland or connector.

Shut down power to the installation at the main power distribution board and lock out power before carrying out any installation or maintenance work.

Shut down power to the installation when it is not in use.

Before using the Exterior Dot-HP Pro, check that all power distribution equipment and cables are in perfect condition, are rated for the current requirements of all connected devices, are protected to IP67 or higher and are of suitable type for the location (including water, pollution, temperature and UV resistance).

Isolate the installation from power immediately if any product, cable, connector, seal, cover or other component is damaged, defective, deformed or showing signs of overheating. Do not reapply power until repairs have been completed.

The Exterior Dot-HP Pro is IP67-rated. It is suitable for use in wet locations, but do not immerse it in water or install it in a location where it may become submerged. Ensure sufficient drainage to cope with the heaviest rainfall. Make sure that water can drain away from the installation area at least as fast as it can enter it.

Do not allow water to collect on or near the pressure equalization valve located on the rear of the device. Do not cover, immerse or block the valve. Check the valve periodically. If it appears dirty, it may be becoming blocked. Contact an authorized Martin service agent for possible replacement.

Arrange cables so that they arrive at connectors from below. Create a 'drip loop' if necessary. With this arrangement, gravity will cause any condensation or water droplets to run away from connectors.

The Exterior Dot-HP Pro accepts DC power at 48 volts from a suitable Martin device or generic external 48 V PSU. Do not connect it to power at any other voltage.

The Exterior Dot-HP Pro has the following power characteristics:

- DC voltage: 48 V +/- 4%
- Typical total power consumption: 5.5 W at full intensity, full white
- Surge protection: 4 kV.

Safety limits for connecting devices

Do not exceed the maximum safety limits given below:

- The maximum number of Exterior Dot-HP Pro devices that you can connect in one daisy-chain is 70.
- The maximum permitted total length of a chain of Exterior Dot-HP Pro devices is 90 m (295 ft.). When you calculate the total length of the chain, include:
 - 50 cm (20 ins.) per device for cable tails, plus
 - the length of the lead-in cable (cable between the DC power source and the first Exterior Dot-HP Pro device), plus
 - the length of all extension cable added between devices.
- The maximum permitted length of a lead-in cable is 90 m (295 ft.).
- The maximum permitted length of cable between two Exterior Dot-HP Pro devices is 90 m (295 ft.). If you need to position two Exterior Dot-HP Pro devices with a distance longer than 90 m between them, insert a *DCE Data Splitter/Booster IP* device available from Martin. This IP66-rated device lets you split a hybrid (power/data) daisy-chain into two lines and/or extend the chain beyond the 90 m (295 ft.) limit.

The Exterior Dot-HP Pro is designed to accept DC power at 48 volts from one of the following sources:

- Martin P3 PowerPort 2000
- Martin P3 PowerPort 500 IP Install
- Martin P3 PowerPort 500 IP Rental
- Martin DCE PSU 240 IP
- Third-party 48 VDC power supply unit.

Please refer to the system diagrams available from Martin for full details of configuration options. You can download these diagrams from the Exterior Dot-HP Pro product page at www.martin.com.

Martin P3 PowerPort 2000

If you supply Exterior Dot-HP Pro devices with DC power from a Martin P3 PowerPort 2000, you may connect one linked chain of Exterior Dot-HP Pro devices per hybrid (48 VDC and data) output on the P3 PowerPort 2000. Since the P3 PowerPort 2000 has four hybrid outputs, you can connect a maximum of four chains of devices to one P3 PowerPort 2000.

Martin P3 PowerPort 500 IP Install

If you supply Exterior Dot-HP Pro devices with DC power from a Martin P3 PowerPort 500 IP Install, you may connect one linked chain of Exterior Dot-HP Pro devices to the hybrid (48 VDC power and data) output of the P3 PowerPort 500. Do not connect more than one chain to this output.



Protection from eye injury

Do not stare directly into the Exterior Dot-HP Pro device's light output.

Do not look at the light output with magnifiers, telescopes, binoculars or similar optical instruments that may concentrate the light output.

Ensure that nobody is looking directly into the front of the device when it lights up suddenly. This can happen when power is applied or when the device receives a control signal.

Provide well-lit conditions to reduce the pupil diameter of anyone working on or near the device.

Wear protective glasses when working on or near the device.



Protection from injury

Fasten the Exterior Dot-HP Pro securely to a fixed surface or structure when in use. The device is not portable when installed.

To reduce the risk of strangulation, all flexible wiring connected to the device shall be effectively fixed to the installation surface or structure if the wiring is within arm's reach.

Each Exterior Dot-HP Pro weighs 395 g (0.9 lb.), not including flange bracket.

Ensure that any supporting structure and/or hardware used can hold at least six (6) times (or more if required by local regulations) the weight of all the devices they support.

The safety and suitability of lifting equipment, installation location, anchoring method, mounting hardware and electrical installation are the responsibility of the installer.

All fasteners used to mount Exterior Dot-HP Pro devices must be suitable for the application, corrosion resistant to suit the environment and strong enough to mount the device safely.

Block access below the work area and work from a stable platform whenever installing, setting, adjusting, or cleaning the device.

After installation or service, check that the device, all accessories and all rigging hardware used are securely fastened in place.

Precautions to avoid damage

Important! To get the best out of the Exterior Dot-HP Pro and avoid causing damage that is not covered by the product warranty, make sure that everyone who is involved in installing, working on or using the Exterior Dot-HP Pro has read and understood the following information.

Cleaning

Excessive dirt buildup causes overheating and may lead to damage that is not covered by the product warranty. Clean the product at regular intervals (see "Cleaning" on page 32).

Operating temperature precautions

- Do not operate the Exterior Dot-HP Pro in an ambient temperature lower than -30° C (-22° F) or higher than the specified maximum of 55° C (131° F) for showing average video content.
- Exterior Dot-HP Pro devices have an internal thermal sensor. If the sensor measures excessive temperature, a thermal protection cutout shuts down the device. The device will function normally again when the temperature has fallen to a safe level.
- When using a Martin P3 System Controller you can enable "thermal throttling" functionality. This feature gradually dims devices if they get hot, avoiding full thermal shutdowns.

Sealing unused connectors with blanking caps

Blanking caps for male and female hybrid DCE connectors can be ordered separately from Martin. Install blanking caps on all unused DCE connectors to seal them against water and dirt, otherwise short-circuits and damage may occur.

Maintaining IP67 protection

The Exterior Dot-HP Pro is supplied as a sealed unit. Do not try to disassemble the product in any other way, or you will affect the product's IP67-rated weatherproofing. This may cause the product to malfunction and lead to damage that is not covered by the product warranty.

Protecting connections from moisture

Moisture can cause corrosion in unprotected cable connections. Moisture can also be sucked along the inside of cables at breaks or cuts in the cable jacket (for example at connection points) and into devices because of the vacuum effect of temperature fluctuations inside devices. To protect connections and devices from moisture, take at least one of the following precautions:

- Locate cable junctions in dry areas (e.g. junction boxes in dry locations).
- Use connectors or junction boxes that are protected to IP67 or higher.
- Fill junction boxes with potting compound to seal the ends of cables and to protect connections from corrosion.

Pressure relief vent

A vent with a gas-permeable membrane in the base of the Exterior Dot-HP Pro equalizes pressure by allowing air to pass through it when the product heats up and cools down, but at the same time it acts as a barrier to water in liquid form. The expulsion of warm air (with a slightly higher water vapor content) and intake of cool air (with a slightly lower water vapor content) prevents humidity buildup over time, provided that the vent works correctly and that the product is correctly sealed.

See illustration on right. The vent is visible in the center of the device when you look from the front of the device. This is not a mistake – it is a design feature that minimizes any risk of condensation.

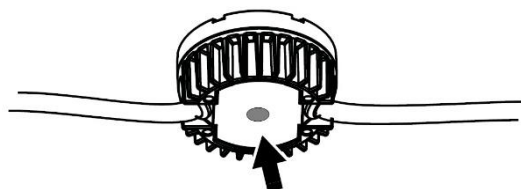

Vents become blocked over time as the micropores in the membrane fill with particles. If a vent becomes blocked by dirt – or by water if it has formed a pool over the vent – excess pressure can damage seals or cause air and even water to be sucked into the product along cables. Vents cannot be cleaned and must be replaced if not in perfect condition. Vent replacement intervals depend on the

amount of airborne dirt and dust in the installation location. Please contact an authorized Martin service agent for vent replacement.

- Any water that reaches the base of an Exterior Dot-HP Pro device will normally drain away, so there is normally no risk of water forming a pool on a vent. However, do not install a device in any way that prevents rainwater, condensation etc. from draining away from the base of the device.
- Contact an authorized Martin service agent for vent replacement if the vent shows signs of contamination or is not in perfect condition.
- Vents must be replaced by an authorized Martin service agent after an extended period of use. Intervals for vent replacement depend on the installation environment.

Keeping connections dry

Moisture on connectors can cause short circuits and damage to products. Check that all connectors are perfectly dry before you connect them.

Do not install the Exterior Dot-HP Pro during wet weather conditions or if condensation is visible on any surfaces.

Avoiding shocks and stress

Do not expose the Exterior Dot-HP Pro to physical shocks (by dropping onto a hard surface, for example).

Do not apply pressure to or otherwise stress diffusers or lenses.

Do not stress cables (by bending them sharply, for example). Protect cables from sharp edges. Note that sub-zero temperatures cause stress in cable materials.

Protecting from galvanic corrosion

Exterior Dot-HP devices are powder-coated, but take precautions to avoid direct contact between aluminum and other metals because this can cause galvanic corrosion:

- Use an electrically insulating material (such as rubber or plastic) or a protective coating between aluminum mounting profiles and any other metal.
- Use a non-conductive coating such as Delta Seal on fasteners (screws, bolts, washers, etc.) where they come into contact with Dots or mounting profiles.

Introduction

Thank you for selecting an Exterior Dot-HP Pro lighting device from Martin®. This Safety and Installation Manual is supplied with the device. It gives details of installing and servicing the device as well as connecting to mains power. The Exterior Dot-HP Pro User Manual, containing full instructions for setting up, controlling and monitoring the device, is available for download from the Exterior Dot-HP Pro area of the Martin website at www.martin.com. If you have any difficulty locating this document, please contact your Martin supplier for assistance.

Devices are supplied with a clear front or diffuser dome installed.

Before installing, operating or servicing an Exterior Dot-HP Pro device, please check the Exterior Dot-HP Pro area of the Martin website at www.martin.com and make sure that you have the latest user documentation for the device.

Not all product specifications are included in the device's user documentation. You can find full specifications for the device in the Exterior Dot-HP Pro area of the Martin website. The online specifications include information to help you order accessories such as cables, PSUs etc.

Each device is supplied with this safety and installation manual.

Optional accessories

The following are available from Martin as optional accessories for the Exterior Dot-HP Pro:

- Flange bracket for surface-mounting the Exterior Dot-HP Pro
- Short 57 mm (2.25 in.) mounting profile with fast installation and release system for surface-mounting one Exterior Dot-HP Pro
- Long mounting profile in 320 mm (12.6 in.) and 1280 mm (50.4 in.) lengths with quick installation and release system for surface-mounting Exterior Dot-HP Pro devices in a perfectly aligned row
- Range of cables, connectors and connector sealing caps.

See the Exterior Dot-HP Pro pages on the Martin website for details and ordering information.

Before using the product for the first time

1. Read 'Safety information' on page 6 before installing, operating or servicing the Exterior Dot-HP Pro.
2. Unpack the device. Please make sure to recycle packaging material.
3. Ensure that there is no transportation damage before using the device. Do not attempt to operate a damaged device.
4. Check the support pages on the Martin Professional website at www.martin.com for the most recent user documentation and technical information about the device. Martin manual revisions are identified by the revision letter at the bottom of the inside cover.

Physical installation



Warning! Read 'Safety information' on page 6 and 'Precautions to avoid damage' on page 10 before installing the Exterior Dot-HP Pro.

Contact your Martin supplier for assistance if you have any questions about how to install this product safely.

Location

Exterior Dot-HP Pro devices are intended for temporary or permanent indoor and outdoor use. With an IP67 rating, they are protected against dust, humidity and water and are able to withstand powerful water jets, but they are not submersible. Do not submerge the device and do not install it in a location where water can build up around the device or under the base of the device. If necessary, provide drainage at the installation location.

Mounting the device

There are three options for installing Exterior Dot-HP Pro devices on a flat surface:

- Mounting directly on the surface.
- Fastening Exterior Dot-HP Pro devices to the optional flange bracket accessories available from Martin and then fastening the flange brackets to a surface.
- Fastening optional Exterior Dot-HP Pro mounting profile to a flat surface first, then installing Exterior Dot-HP Pro devices on the mounting profile. This option lets you install devices in straight lines and lets you conceal up to two cable runs inside the profile, giving a clean appearance.

The Exterior Dot-HP Pro can be installed in any orientation.

See illustration on right. The Exterior Dot-HP Pro cable tails exit the rear of the device at a 45° angle. This gives the option of running cables towards the rear or towards the sides of the Dot, catering for a range of cable installation options.

Do not install Exterior Dot-HP Pro devices with a cable run longer than 90 m (295 ft.) between any two devices.

Allow free airflow around the device and at least 10 mm (0.4 in.) of clearance around the front surface.

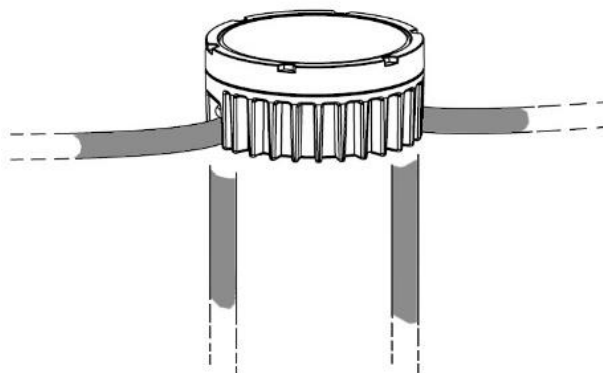

Fasteners

All fasteners must be suitable for the application and environment. Steel fasteners must be grade 8.8 minimum according to ISO 898-1. Stainless steel fasteners must be grade 304 (A2) or better – and in marine environments stainless steel fasteners must be grade 316 (A4) or better – according to ISO 3506.

To minimize the risk of galvanic corrosion, apply a non-conductive coating such as Delta Seal to all parts of the fasteners that will come into contact with the Exterior Dot-HP Pro.

Mounting directly on a surface

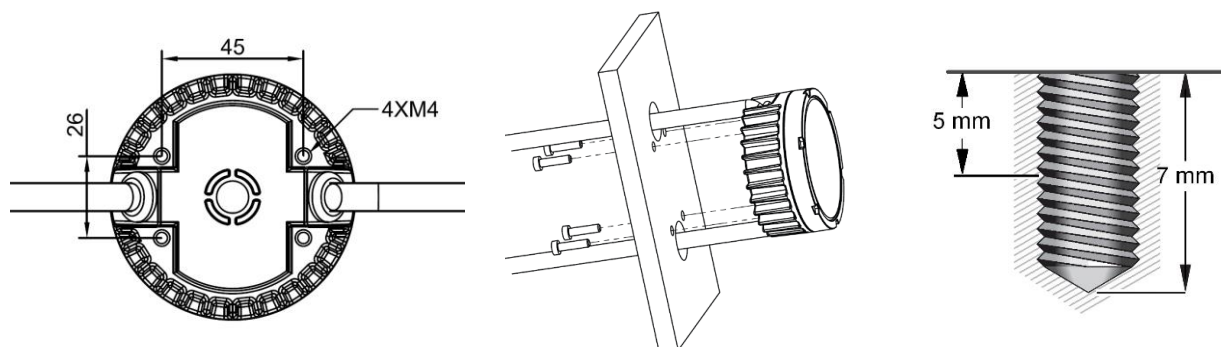

To fasten an Exterior Dot-HP Pro device directly to a flat surface where you have access to the rear of the surface:

1. See illustrations above. Pre-drill holes for the cables and fasteners, taking the dimensions from the drawing above.
2. Obtain four M4 screws or bolts and washers that are all suitable for the environment and application. Check that the screws will pass minimum 5 mm (0.2 in.) and maximum 7 mm (0.28 in.) into the device when passed through the surface and tightened.
3. Pass the screws or bolts through the washers and then through the mounting surface from the rear. Then tighten them into the device.
4. Check that the Exterior Dot-HP Pro is held securely.

Installing using a flange bracket

The flange brackets available from Martin as optional accessories for the Exterior Dot-HP Pro are recommended for installation on a flat surface or structure where you do not have access to the rear of the surface, or simply for more convenient installation on any surface.

To install an Exterior Dot-HP using a flange bracket:

1. flange bracket See illustration on right. Pass the four screws **A** supplied with the flange bracket through the bracket and fasten them into the base of the device.
2. Fasten the flange bracket to the mounting surface using two high-strength corrosion-resistant fasteners **B** that are suitable for the application and the environment. Use the two supplied nylon shoulder washers (arrowed in illustration above) with the fasteners. Use screwplugs if necessary for a secure installation. Any nuts used must be self-locking.
3. Check that the Exterior Dot-HP Pro is held securely.

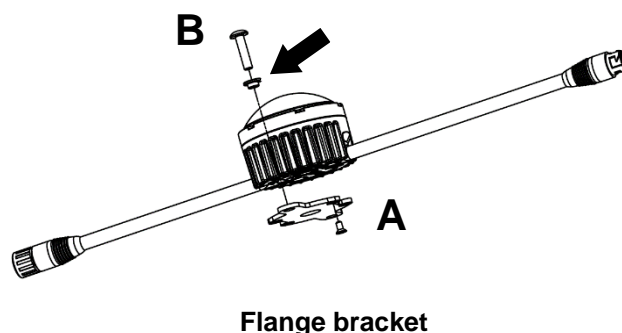

Installing using mounting profile

To simplify installation on a surface, Martin can supply aluminum mounting profiles and brackets for the Exterior Dot-HP Pro as optional accessories (see the Exterior Dot-HP Pro pages on the Martin website at www.martin.com for details and ordering information). You can fasten the mounting profiles to the surface and then fasten Exterior Dot HP devices into the profiles by means of mounting brackets.

Mounting profile is available in 57 mm (2.25 in.) lengths that are suitable for one device as well as 320 mm (12.6 in.) and 1280 mm (50.4 in.) lengths that simplify mounting in perfectly straight lines and can be cut into shorter sections if required.

The mounting profile is deep enough to hold two cable runs behind an Exterior Dot-HP Pro device.

See illustration below. Installing in mounting profile involves the following items:

- Bracket **B**
- M4 x 8 mm screws **C** for fastening devices to brackets, four screws per device
- Mounting profile **D**
- Locking blocks **E** and M4 locking bolt **F**
- Loctite 243 or equivalent thread locking compound.

Installing in 57 mm mounting profile

To mount an Exterior Dot-HP Pro device in 57 mm mounting profile:

1. See illustration on right. Fasten each device **A** to a mounting profile bracket **B** using the four supplied screws **C**. Apply a small quantity of Loctite 243 to the screw threads and use a torque driver to tighten to a torque of 2 Nm.

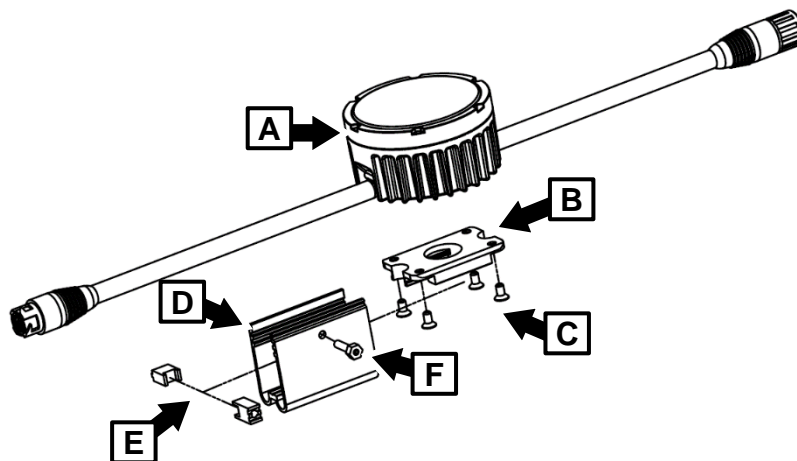

57 mm mounting profile

2. For each mounting profile, obtain two M6 (quarter-inch) fasteners (screws, screwbolts, etc.) and screwplugs if screwing into a wall, for example. Check that fasteners are of suitable type and length for the application and have appropriate corrosion resistance. Apply an electrically insulating coating such as Delta Seal to fasteners to prevent contact between the aluminum profile and the fasteners. If necessary, use electrically insulating material to prevent contact between the aluminum profile and any other metals when the profile is installed.
3. With reference to the mounting profile dimensions drawing at the beginning of this manual, prepare two holes with centers 20 mm (0.55 in.) apart to accept the fasteners for each mounting profile. Use screw plugs if necessary for a secure installation.
4. Fasten each mounting profile **D** securely to the surface or structure using two fasteners per profile.
5. If you are going to install the Exterior Dot-HP Pro device now, apply a small quantity of Loctite 243 to the threads of the locking bolt **F** (if you are going to install the device in the profile later, apply the Loctite when you install the device).
6. See photo on right. Assemble the locking blocks **E** and place them in the grooves in the mounting profile as shown. Tighten the bolt **F** through the mounting profile and into the locking blocks finger-tight only.
7. Connect the Exterior Dot-HP Pro device's input connector to the output connector of the previous device on the link, either directly or via a patch cable. Make sure that all connectors are correctly fastened together with locking rings twisted to ensure a seal.

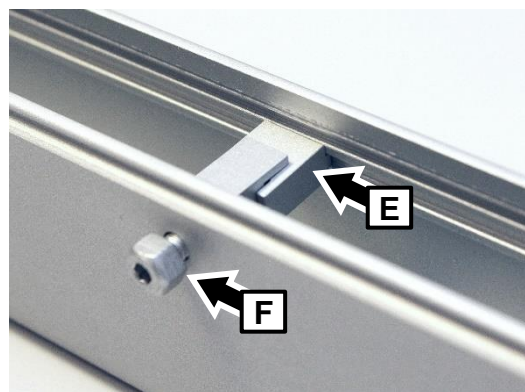

Locking blocks

8. See illustration on right. Clip the device onto the mounting profile so that the lips on the mounting bracket engage in the channels on both sides of the profile as shown at **G**.
9. Tighten the M4 locking bolt **F** to expand the locking blocks **E** and secure the device in the profile. The locking bolt accepts a 2.5 mm Allen key or a 7 mm wrench. Tighten the bolt to a torque of 1 Nm (0.75 ft.-lbs.) using a torque driver or torque wrench.
10. When you have tightened the bolt, check that the head of the bolt sits flat against the mounting profile.
11. Check that the Exterior Dot-HP Pro is held securely.

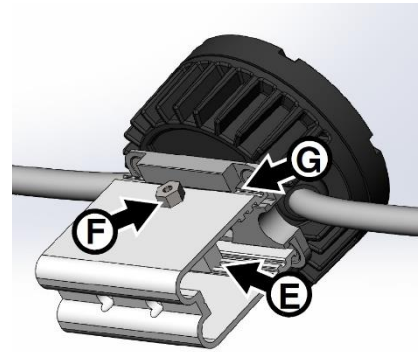

Installing in mounting profile

Installing in long mounting profile

To install Exterior Dot-HP Pro devices on a surface using the 320 mm and 1280 mm lengths of mounting profile available from Martin, follow the directions given above for 57 mm profiles, but note the following:

- You can cut profile to custom lengths with a hacksaw or angle grinder. After cutting, remove burrs and sharp edges (with a metal file, for example).
- 6.5 mm (quarter-inch) diameter holes are provided at 258 mm (10.2 in.) intervals in the base of the profile for fastening the profile to the mounting surface. You can drill more holes if required.
- 4 mm (0.16 in.) diameter holes for locking bolts **F** are provided at 200 mm (7.87 in.) intervals in the mounting profile but it is possible to drill more holes if required to match the spacing between devices.

System installation



Warning! Read ‘Safety information’ on page 6 and ‘Precautions to avoid damage’ on page 10 before connecting Exterior Dot-HP Pro devices to DC power and data.



Warning! Connect the Exterior Dot-HP Pro only to the devices and using only the Martin cables specified in this manual and in the Exterior Dot-HP Pro User Manual.

Warning! Do not exceed the maximum numbers of devices that can be connected in chains and maximum cable lengths specified in ‘Protection from electric shock’ on page 7 and in the manuals of the other devices in the system.

The Exterior Dot-HP Pro is designed to display either Martin P3 video or DMX-controlled lighting effects. It automatically recognizes and responds to Martin P3, Art-Net, RDM via Art-Net and sACN data signals.

System diagrams

See the system overview diagrams available for download from the Exterior Dot-HP Pro area of www.martin.com and see the Exterior Dot-HP Pro User Manual for details of connecting and setting up an Exterior Dot-HP Pro system.

Creating a display system

To install a system that displays P3 video or DMX-controlled creative lighting effects on Exterior Dot-HP Pro devices:

1. Make sure that no devices in the installation can be connected to AC mains power until all installation work is complete.
2. Read “Safety information” on page 6 and “Precautions to avoid damage” on page 10.
3. Connect Exterior Dot-HP Pro devices together in chains either directly using the hybrid DCE connectors on the devices’ cable tails or via hybrid extension cables with DCE connectors available from Martin (see the Exterior Dot-HP Pro area of www.martin.com for ordering information).

Warning! Do not exceed the maximum number of devices per chain given in “Safety information” on page 6.

4. Install a blanking cap available from Martin (see the Exterior Dot-HP Pro area of the Martin website at www.martin.com for ordering information) on the output connector of the last Exterior Dot-HP Pro device on each chain to prevent the entry of water, dirt etc. Note that water can be sucked up cables that do not have a blanking cap installed and that this can cause damage that is not covered by the product warranty.
5. There are two options for connecting a chain of Exterior Dot-HP Pro devices to 48 volt DC power and data.
 - a) You can connect to one of the following hybrid (combined power + data) sources:
 - one of the four hybrid outputs of a Martin P3 PowerPort 2000 (this device has DCE connectors for hybrid output),
 - the hybrid output of a Martin P3 PowerPort 500 IP Rental (this device has a DCE connector for hybrid output), or
 - the hybrid output of a Martin P3 PowerPort 500 IP Install (this device has terminals inside a connections box and cable glands for cable entry).

You must then connect the Martin P3 PowerPort device to mains power and to a Martin P3 System Controller. See the P3 PowerPort user manual for instructions.

If necessary, add a DCE hybrid extension cable between the P3 PowerPort and the first Exterior Dot Pro HP device. DCE-to-DCE extension cables are available from Martin in various lengths.

b) You can draw 48 volt DC power from:

- the 48 volt output of a Martin DCE PSU240W (this device has quick-connectors inside a connections box and cable glands for cable entry), or
- the output of a third-party 48 volt DC external PSU with a suitable current rating.

You can then take data from a Martin P3 System Controller and add the data together with the 48 volt DC power to the Exterior Dot-HP Pro hybrid link using a suitable Input Adapter cable available as an accessory from Martin.

Follow the instructions in the user documentation of the above devices when making connections. The wires in the Exterior Dot-HP Pro hybrid cables are color coded as follows:

48 VDC power

- Red = Positive (+)
- Black = Negative (-) / ground

Data

- TX+ = White/orange
- TX- = Orange
- RX+ = White/green
- RX- = Green
- Data shield

Testing

Exterior Dot-HP Pro devices are programmed with a test sequence that is activated by swiping (moving) a magnet past a magnetic switch inside the device. The location of the switch is indicated with a magnet icon (arrowed in photo on right) on the side of the device.

We recommend that you use the Magnetic Multitool/Tester available from Martin (see photo below right).

Swiping a magnet past the magnetic switch causes the Exterior Dot-HP Pro to step through the following sequence:

1. Display device status code (see table on next page for key to codes).
2. Calibrated mixed White at full intensity.
3. All Red LEDs at full intensity.
4. All Green LEDs at full intensity.
5. All Blue LEDs at full intensity.
6. All White LEDs at full intensity.
7. Exit sequence and resume normal operation.

In addition to step 7. above:

- You can resume normal operation by cycling power to the Dot off and on.
- If you are already sending a control signal to the Dot via DMX (including sACN and Art-Net) or P3, the Dot will exit the sequence and return to normal operation approximately 30 seconds after the last magnet swipe.
- If the Dot has not been receiving a control signal via DMX (including sACN and Art-Net) or P3 but it begins to receive one, the Dot will return to normal operation immediately.



Device status codes

Exterior Dot-HP Pro devices indicate their status by lighting all their LEDs as follows:

LED color	Signal	Status
Blue	Constant	Busy (booting or uploading SW).
Red	Constant	Error. The fixture has detected an error and cannot run.
Red	Flashing	No control source detected (no P3, Art-Net or sACN detected on Ethernet).
Green	Constant	Ready. P3 packets detected, but fixture not in joined state
Green	Flashing	Running normally in P3 mode (P3 joined).
Cyan	Constant	Ready. Fixture in Art-Net/sACN mode but not receiving valid DMX data.
Cyan	Flashing	Running normally in Art-Net/sACN mode.

Device status codes

Maintenance



Warning! Read ‘Safety information’ on page 6 before carrying out service or maintenance. There are no user-serviceable parts inside. Do not open the housing. Refer any service operation not described in this manual to Martin Professional or its authorized service agents.

Installation, on-site service and maintenance can be provided worldwide by the Martin Professional Global Service organization and its approved agents, giving owners access to Martin’s expertise and product knowledge in a partnership that will ensure the highest level of performance throughout the product’s lifetime. Please contact your Martin® supplier for details.

Be aware that the output of LEDs, like all light sources, changes gradually over many thousands of hours of use. If you require products to perform to very precise color specifications, you may eventually need to make small readjustments at the lighting controller.

Cleaning

Regular cleaning is essential for service life and performance. Buildup of dust and dirt will reduce the Exterior Dot-HP Pro’s light output and cooling ability.

Cleaning schedules will vary greatly depending on the operating environment. It is therefore impossible to specify precise cleaning intervals for the Exterior Dot-HP Pro. Inspect devices within their first few weeks of operation to see whether cleaning is necessary. Check again at frequent intervals. This procedure will allow you to assess cleaning requirements in your particular situation. If in doubt, consult your Martin dealer about a suitable maintenance schedule.

Do not use products that contain solvents, abrasives or caustic agents for cleaning, as they can cause surface damage. The aluminum housing and front glass can be cleaned with mild detergents such as those for washing cars.

To clean the housing and front glass or diffuser dome:

1. Isolate the installation from power and allow the device to cool for 20 minutes.
2. Visually check that the device, seals and cables are in good condition. If any seal or cable shows signs of damage, cracking or loss of water resistance, stop cleaning the device and contact a Martin authorized service technician for replacement.
3. Rinse off loose dirt with a hose or low-pressure water spray.
4. Wash the aluminum housing and front glass using warm water with a little mild detergent and a soft brush or sponge. Do not use abrasive cleaners.
5. Rinse with clean water and wipe dry.

Pressure relief valve

A valve with a gas-permeable membrane on the back of the Exterior Dot-HP Pro (see illustration on right) equalizes pressure by allowing air to pass through it when the device heats up and cools down. At the same time, the valve acts as a barrier to water in liquid form. The expulsion of warm air (with a slightly higher water vapor content) and intake of cool air (with a slightly lower water vapor content) prevents humidity buildup over time, provided that the valve works correctly and that the Exterior Dot-HP Pro is correctly sealed.

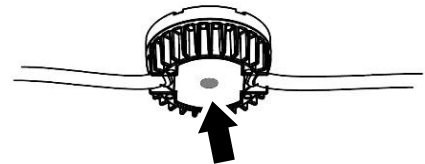

Pressure relief valves have a limited service life. They become blocked over time as the micropores in the membrane fill with particles. When a valve becomes blocked, excess pressure can damage seals or cause air and even water to be sucked into the device along cables. A blocked valve cannot be cleaned and must be replaced if it shows any signs of contamination or is not in perfect condition.

For maximum service life, have the pressure relief valve replaced after an extended period of use or if it shows signs of dirt buildup. Intervals for valve replacement depend on the installation environment. Please consult your Martin dealer about a suitable replacement schedule. If valve replacement becomes necessary, contact Martin Service for assistance.

Specifications and compliance

For product specifications, please see the Exterior Dot-HP Pro area of the Martin website at www.martin.com.

FCC compliance

This equipment has been tested and found to comply with the limits for a Class B digital device, pursuant to part 15 of the FCC Rules. These limits are designed to provide reasonable protection against harmful interference in a residential installation. This equipment generates, uses and can radiate radio frequency energy and, if not installed and used in accordance with the instructions, may cause harmful interference to radio communications. However, there is no guarantee that interference will not occur in a particular installation. If this equipment does cause harmful interference to radio or television reception, which can be determined by turning the equipment off and on, the user is encouraged to try to correct the interference by one or more of the following measures:

- Reorient or relocate the receiving antenna.
- Increase the separation between the equipment and receiver.
- Connect the equipment into an outlet on a circuit different from that to which the receiver is connected.
- Consult the dealer or an experienced radio/TV technician for help.

FCC supplier's declaration of conformity declaration

This device complies with part 15 of the FCC Rules. Operation is subject to the following two conditions:

1. This device may not cause harmful interference, and
2. this device must accept any interference received, including interference that may cause undesired operation.

Canadian Interference-Causing Equipment Regulations – Règlement sur le Matériel Brouilleur du Canada

This Class B digital apparatus meets all requirements of the Canadian Interference-Causing Equipment Regulations. *Cet appareil numérique de la classe B respecte toutes les exigences du Règlement sur le Matériel Brouilleur du Canada.*

CAN ICES-003 (B) / NMB-003 (B)

EU Declaration of Conformity

An EU Declaration of Conformity covering this product is available for download from the Exterior Dot-HP Pro area of the Martin website at www.martin.com.

Disposing of the product



Martin products are supplied in compliance with Directive 2012/19/EC of the European Parliament and of the Council of the European Union on WEEE (Waste Electrical and Electronic Equipment), where applicable.

Help preserve the environment! Ensure that this product is recycled at the end of its life. Your supplier can give details of local arrangements for the disposal of Martin products

