

MAC 700 Wash™ Spill Limiter Kit Installation Guide

Introduction

This Installation Guide explains how to install the Martin™ MAC 700 Wash Spill Limiter Plate Kit, P/N 91614029.

For the latest documentation and information about this and all Martin Professional™ products, please visit the Martin website at www.martin.com.

Warning! *Read and follow the safety precautions in the MAC 700 Wash user manual before installing the Spill Limiter Kit. The user manual is supplied with the MAC 700 Wash and is also available for download from www.martin.com*

Disconnect the fixture from power, allow to cool and place on a workbench before starting work.

The MAC 700 Wash Spill Limiter Kit must be installed by qualified professional technicians only. Read all of this Installation Guide carefully before starting to install the Spill Limiter Kit.

If you have any questions about how to install the Spill Limiter Kit or use the MAC 700 Wash safely, please contact your local Martin distributor (see www.martin.com/distributors for details) or call the Martin 24-hour service hotline on +45 8740 0000, or in the USA on 1-888-tech-180.

Important! *To avoid damage to PCBs and their sensitive electronic components, take precautions to avoid ESD (electrostatic discharge) and carry out work at an ESD-free workstation.*

Do not get oil or grease onto optical components. Do not touch optical components without wearing clean, lint-free cotton gloves. To avoid any possibility of damage, clean all optical components with 99.9% isopropyl alcohol before reinstalling them in the fixture.

Overview

The MAC 700 Wash Spill Limiter Kit contains the following items:

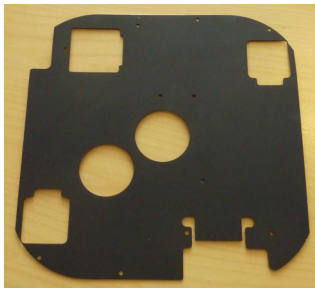

A



B



C



D



E



F



G



H



I



J

Table 1

Parts list

A	1 x spill light cover plate	P/N 23819270	F	1 x M3 x 20 standoff pillars f7/f7	P/N 08053856
B	1 x outer aperture plate	P/N 62409070	G	10 x M3 x 20 standoff pillars m6/f7	P/N 08053814
C	1 x Color wheel w/o filters	P/N 62326075	H	4 x M4 x 10 Torx Taptite screws	P/N 08070701
D	1 x spacer, ø3.2/ø6x3 brass	P/N 08261011	I	1 x spacer, ø3.2/ø6x2 brass	P/N 08261000
E	1 x M3 x 6 Torx screw	P/N 08050702	J	1 x color wheel shutter	P/N 62327266

Tools required

Screw sizes given in this guide are indicative only.

The following tools are normally required to install the Spill Limiter Kit in a MAC 700 Wash as described in this guide. However, if screws have been replaced during service, for example, you may find that other tools are required.

- 5.5 mm open-ended hex wrench
- Torx TX10 and TX20 screwdrivers

- Drill with 3.2 mm (1/8 inch) and 3.8 mm HSS drill bits.

To help you avoid dropping screws into the fixture, we recommend that you magnetize tools. Use of a powered screwdriver with correctly set torque will also save you time.

Installation procedure

To install the MAC 700 Wash Spill Limiter Kit components in a standard MAC 700 Wash fixture:

1. Disconnect the fixture from power, allow to cool, and place on a workbench. Take precautions against ESD (electro-static discharge).

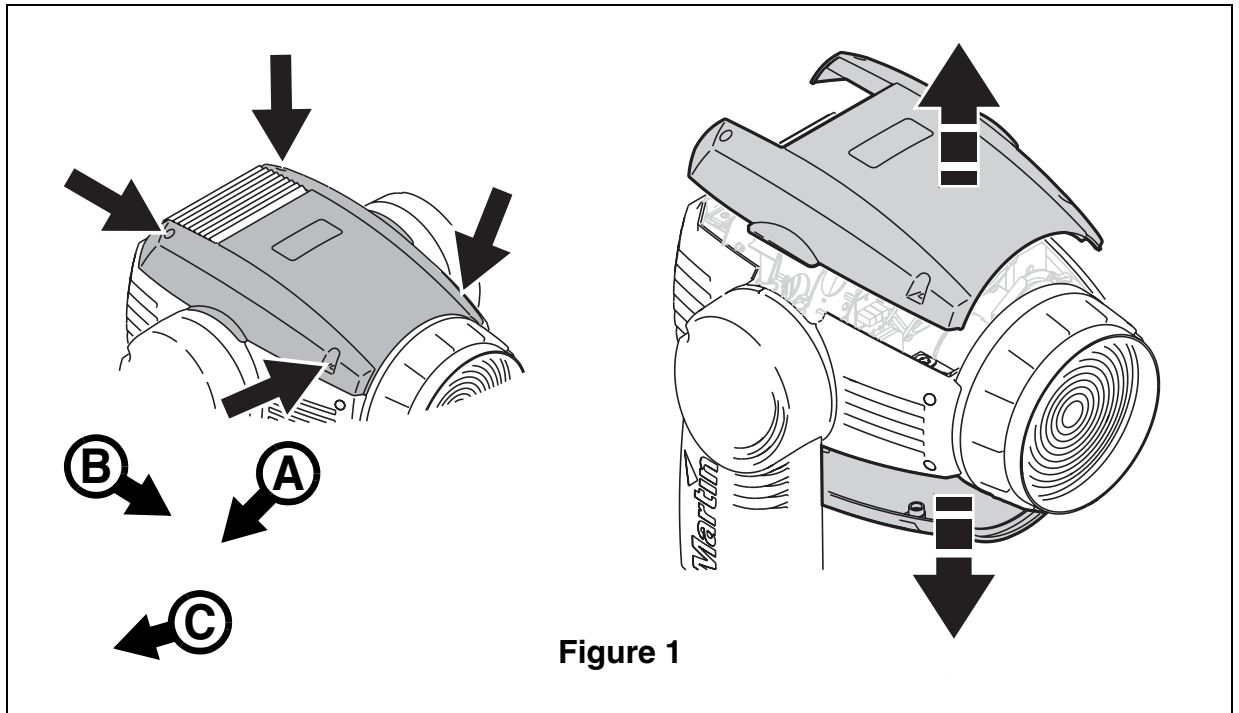

2. See Figure 1. Release the head cover retaining screws (arrowed) and remove the head covers.
3. Apply the tilt lock. See Figure 2. Release the module locks on both sides of the effects module and lift the module out of the head.

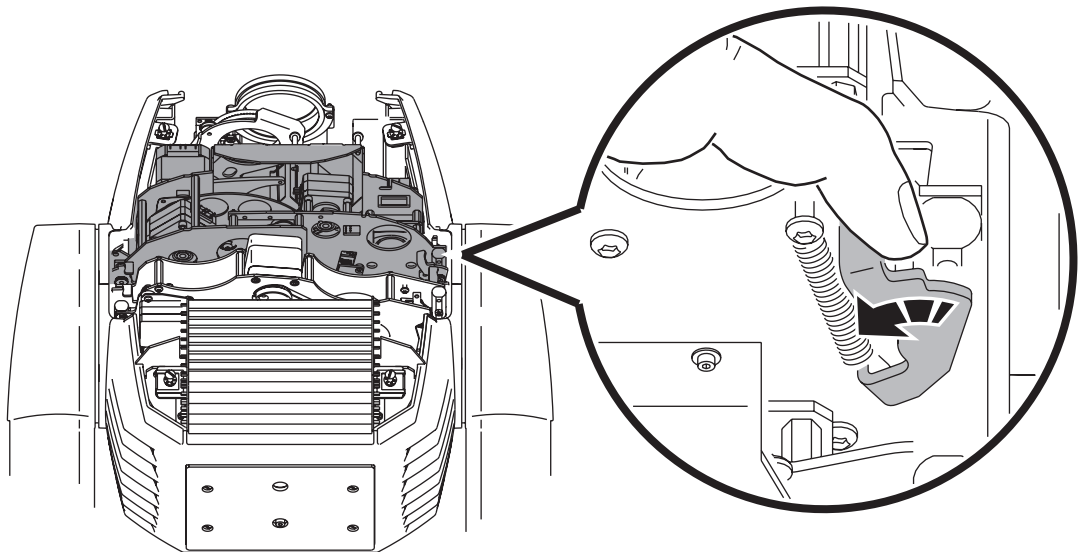

4. See Figure 3. Remove the four Torx M3 x 10 screws (arrowed) from the outer aperture plate and remove the plate. Keep the screws for re-use. The outer aperture plate is no longer required.

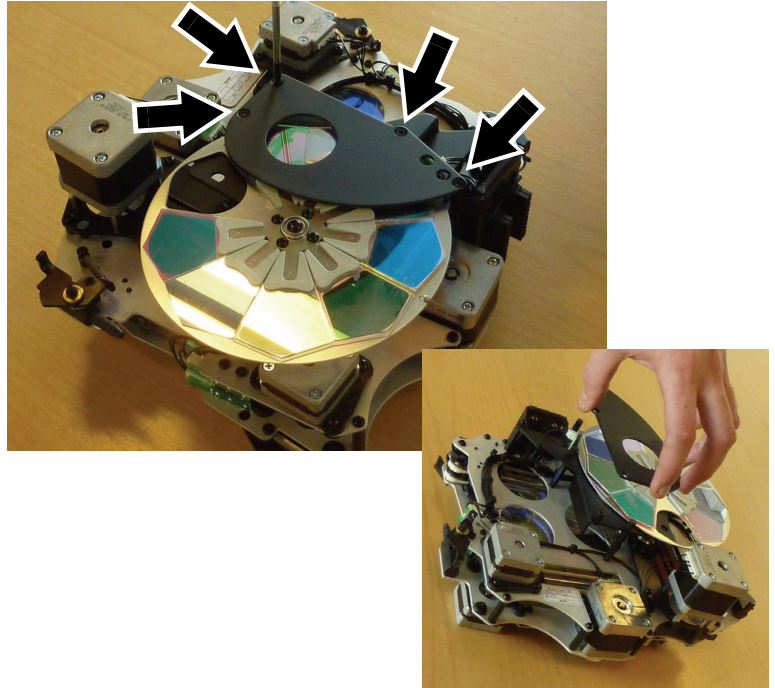

Figure 3

5. See Figure 4. Remove the Torx M4 x 20 screw (arrowed) from the center of the color wheel. Keep this screw for re-fastening the color wheel pulley to its shaft later.

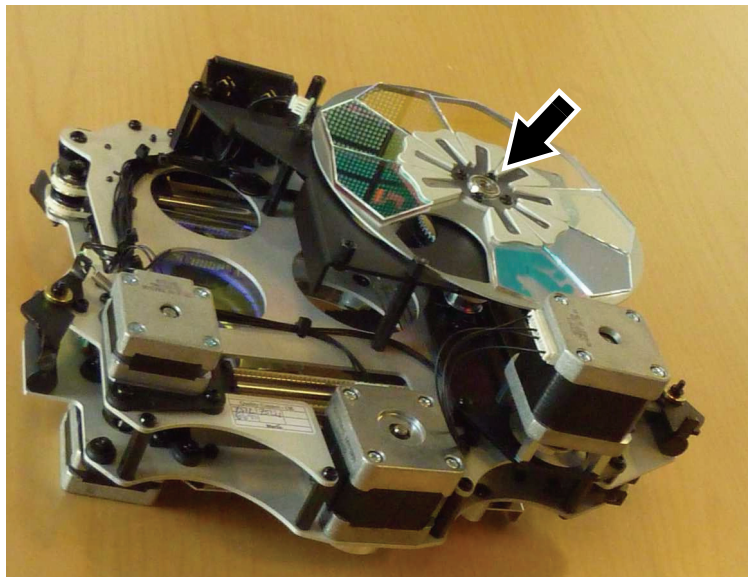

Figure 4

6. See Figure 5. Remove the two screws (arrowed) that fasten the inner aperture plate to the multi-connector mounting bracket

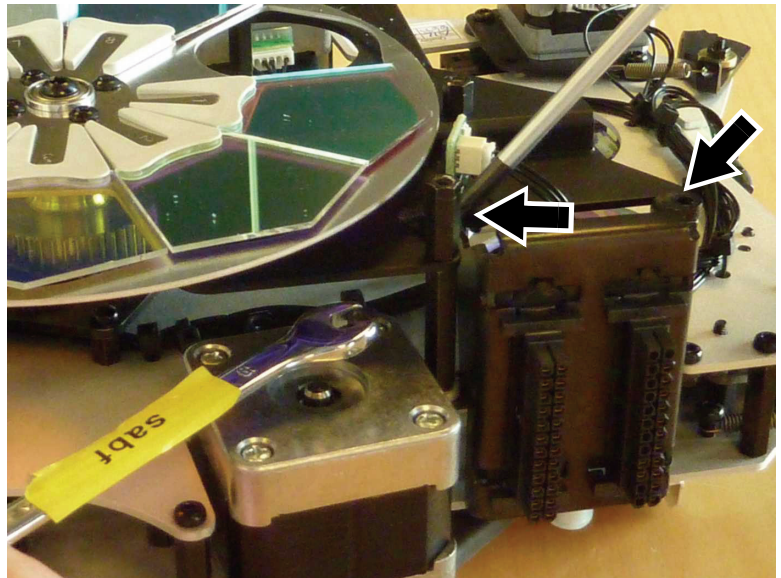

Figure 5

7. See Figure 6. Remove the four pillars (arrowed) from the inner aperture plate.

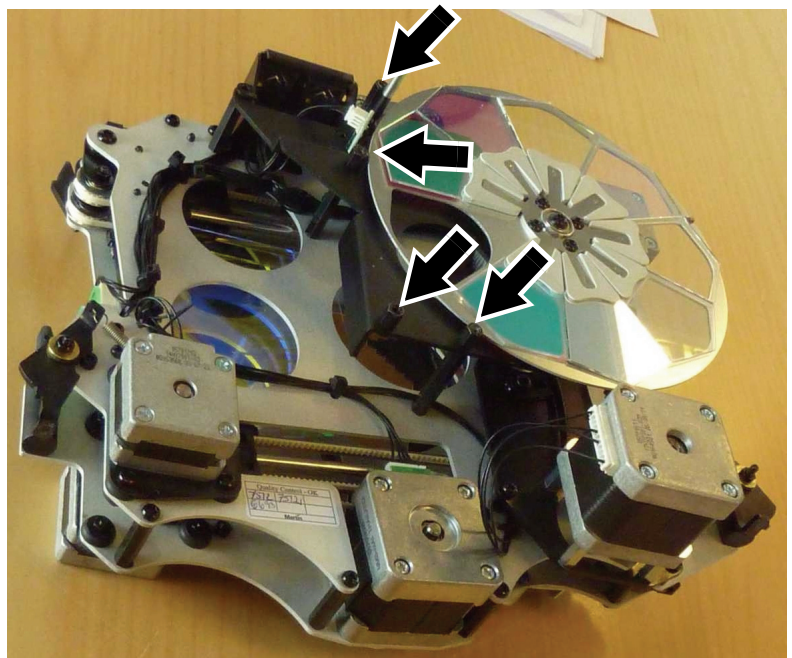

Figure 6

8. See Figure 7. Move the inner aperture plate to one side to give clearance for the color wheel pulley, then lift the color wheel and pulley out of the module.

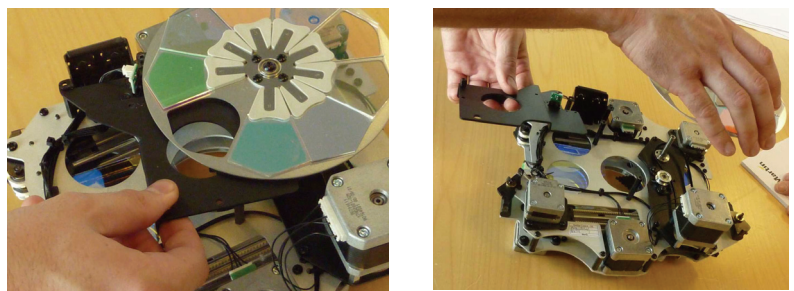

Figure 7

9. See Figure 9. Disconnect the small sensor PCB on the inner aperture plate.

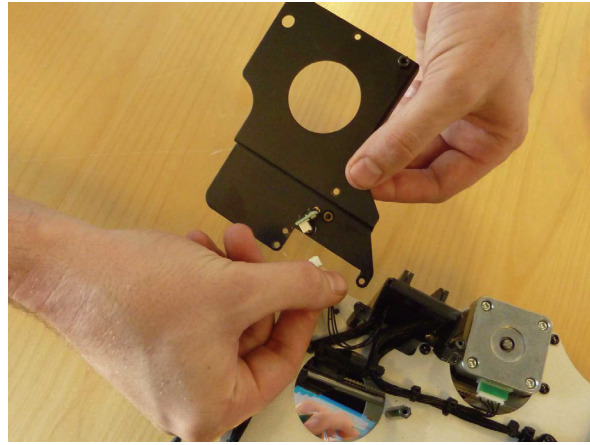

Figure 8

10. See Figure 9. Remove the two Torx 10 sensor PCB mounting screws, and remove the sensor PCB from the inner aperture plate. The inner aperture plate is no longer required.
11. Re-use the screws to install the sensor PCB on the new outer aperture plate (P/N 62409070) supplied in the kit, leaving the sensor PCB as shown in the photo at the bottom of Figure 9.

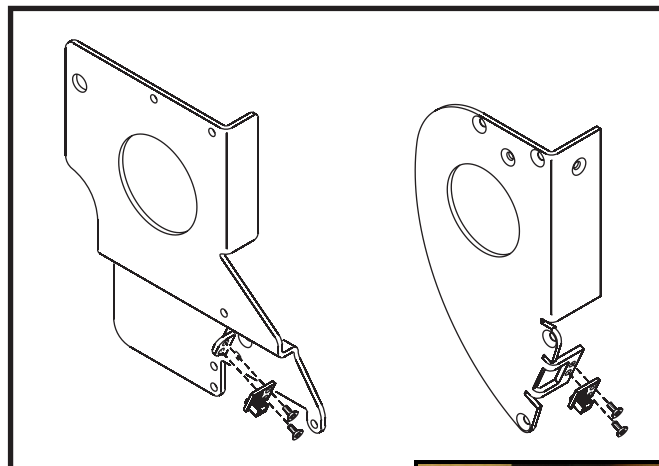

Figure 9

12. See Figure 10. Transfer the filters from the old color wheel to the new one (P/N 62326075) supplied in the kit. Replace one of the colors with the blackout flag (Color Wheel Shutter, P/N 62327266) supplied in the kit if required.

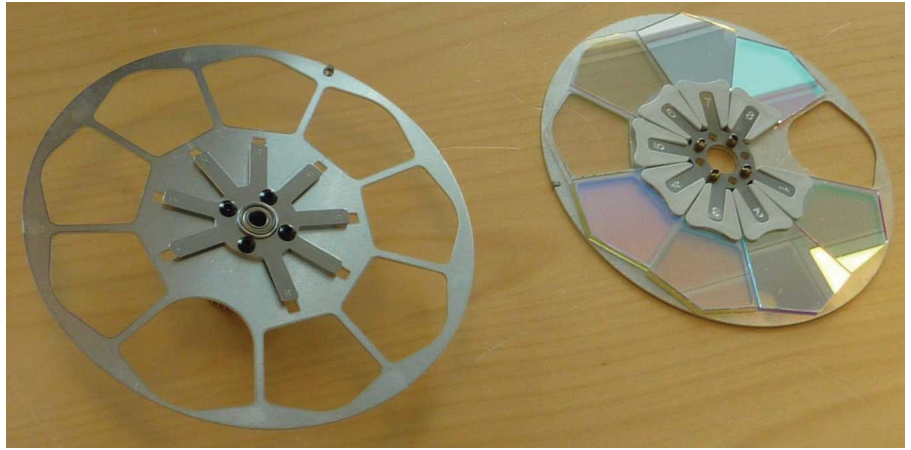

Figure 10

13. See Figure 11. Using a 3.2 mm (or 1/8 inch) HSS drill bit, drill out the rivets that hold the original color wheel onto the color wheel pulley assembly and remove the color wheel. Remove all drilling swarf and any remaining pieces of rivet from the pulley. The original color wheel assembly is no longer required.

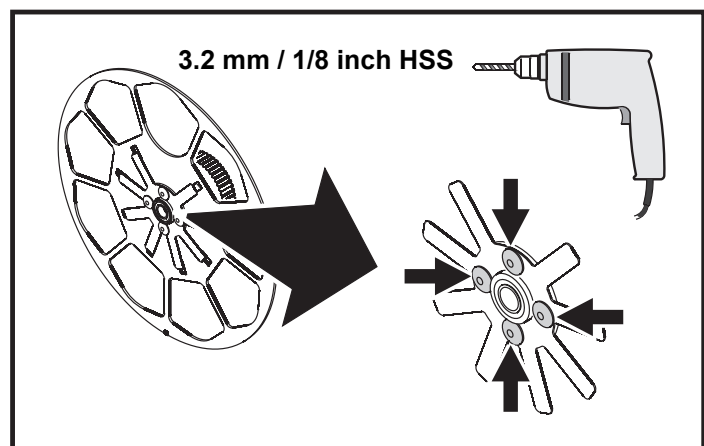

Figure 11

14. See Figure 12. Loosen the color wheel drive belt tensioner locking screw (arrowed) and loosen the belt.

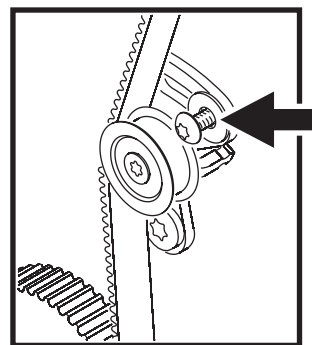

Figure 12

15. See Figure 13. Using a 3.8 mm HSS drill bit, drill through the four holes (arrowed) in the color wheel shaft. Do not use any other size drill bit, as these holes must be precisely dimensioned to accept M4 Taptite self-tapping screws. Brush or blow any swarf away from the shaft and its bearing. Do not spray with any solvents that could enter the bearing and dissolve the bearing lubricant.

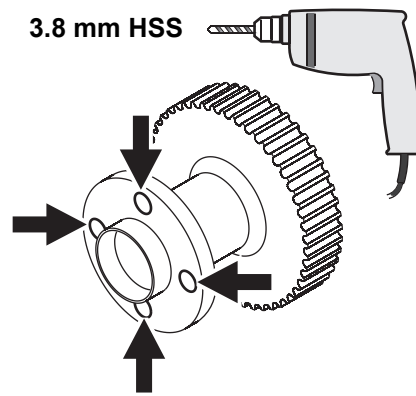
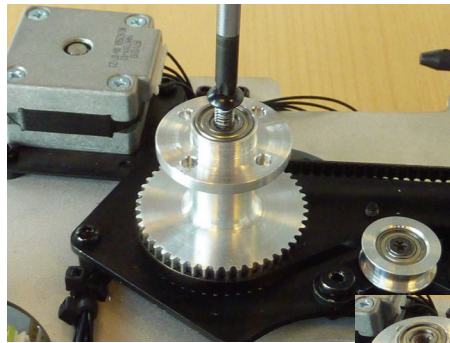

Figure 13

16. See Figure 14. Replace the color wheel pulley on its shaft so that the teeth in the pulley engage in the color wheel drive belt. Fasten the color wheel pulley onto its shaft with the Torx 20 M4 screw you removed in step 5.



17. The color wheel drive belt tensioner auto-adjusts under spring pressure to give the correct tension. Check that the drive belt is correctly seated on all its pulleys and that the tensioner spring is holding the belt under tension, then tighten the tensioner locking screw (arrowed in Figure 14) without disturbing the automatic belt tension.

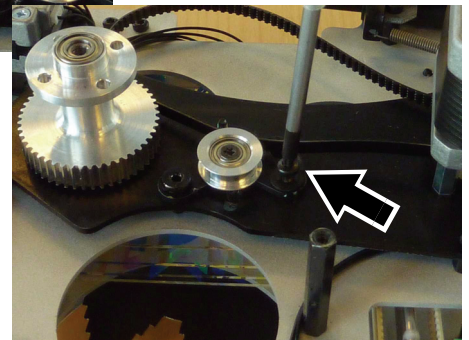

Figure 14

18. See Figure 15. Holding the pillar bolts under the heat deflector plate with a 5.5 mm open-ended wrench, remove the three Torx 10 retaining screws from the heat deflector plate and remove the plate for easier access during the next step.

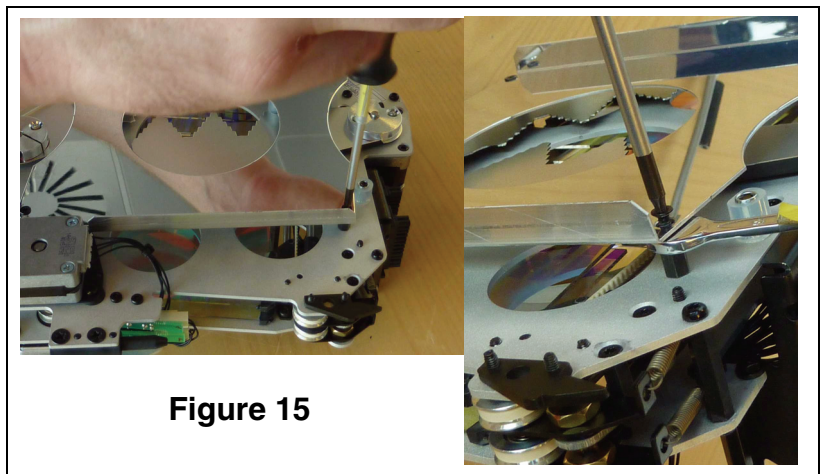

Figure 15

19. See Figure 16. Replace the three M3 x 30 pillar bolts (arrowed) on the inner aperture plate with three of the ten M3 x 20 male/female pillar bolts (P/N 08053814) supplied in the Spill Limiter Kit. Two of the M3 x 30 pillar bolts are held by Torx 10 screws. Hold each screw with a driver from the other side of the module while you remove each pillar bolt and install the new M3 x 20 pillar bolt, using the screw to fasten the new pillar in place.

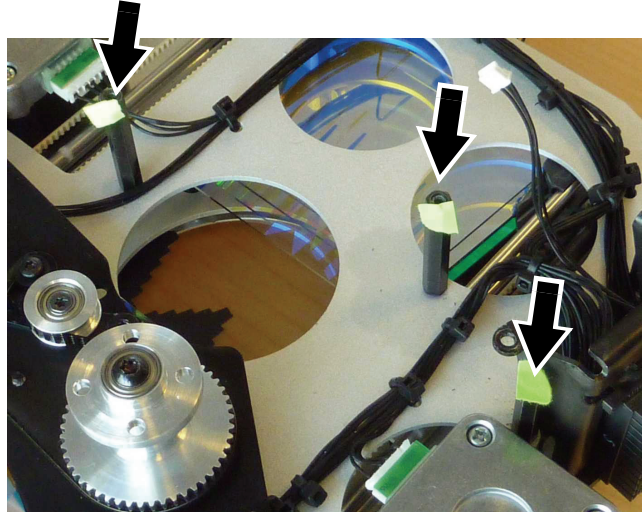

Figure 16

20. See Figure 17. The M3 x 30 pillar bolt next to the multi-connector is held in place with a 5.5 mm nut. Remove the pillar bolt and nut completely and replace with an M3 x 20 pillar bolt, fastening the pillar bolt with the M3 x 6 panhead Torx 10 screw (P/N 08050702) supplied in the kit.

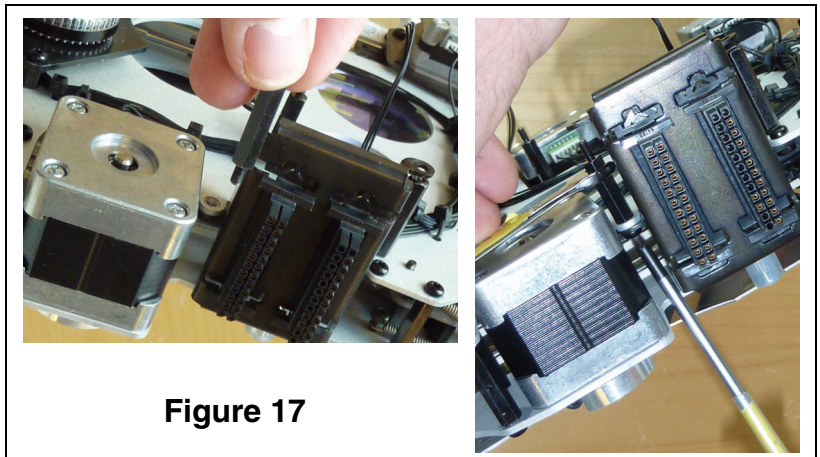

Figure 17

21. See Figure 18. Replace the seven panhead Torx M3 x 10 screws (arrowed) from around the outside of the inner aperture plate with seven of the ten M3 x 20 pillar bolts (P/N 08053814) supplied in the kit. Use a 5.5 mm open-ended wrench to hold the pillar under each screw while you remove the screw and replace it with an M3 x 20 pillar bolt. Keep the original seven screws for re-use.

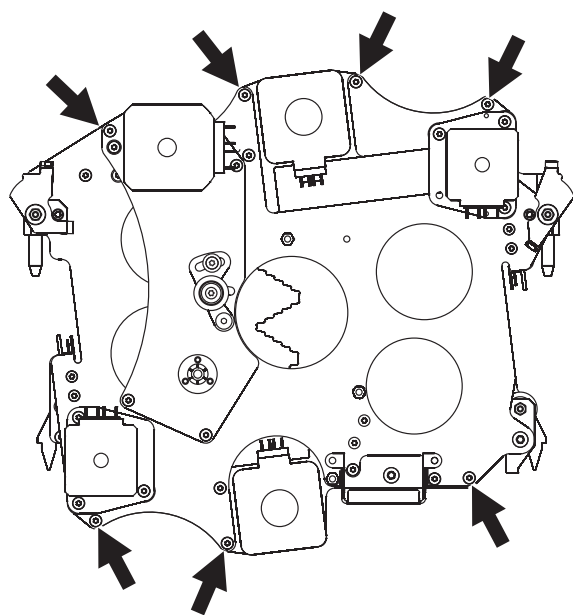

Figure 18

22. See Figure 19. Insert the brass bush (P/N 08261000) supplied in the kit between the multi-connector bracket and its original mounting pillar to take up the space left by the outer aperture plate you removed in step 4. Re-use one of the seven Torx M3 X 10 screws you removed in step 21. to fasten the multi-connector bracket back onto its original pillar with the bush acting as a spacer.

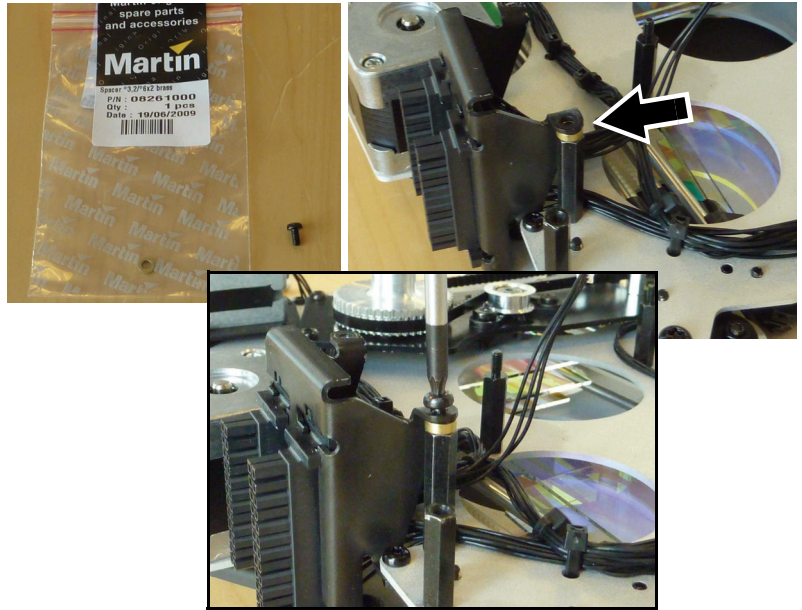

Figure 19

23. See Figure 20. Install one of the four spacers (P/N 08261011) and the female/female pillar (P/N 08053856) supplied in the kit on the hole (arrowed) in the new spill limiter plate (P/N 23819270) supplied in the kit. Make sure that you use the correct hole and install the spacer and pillar facing as shown in the illustration.

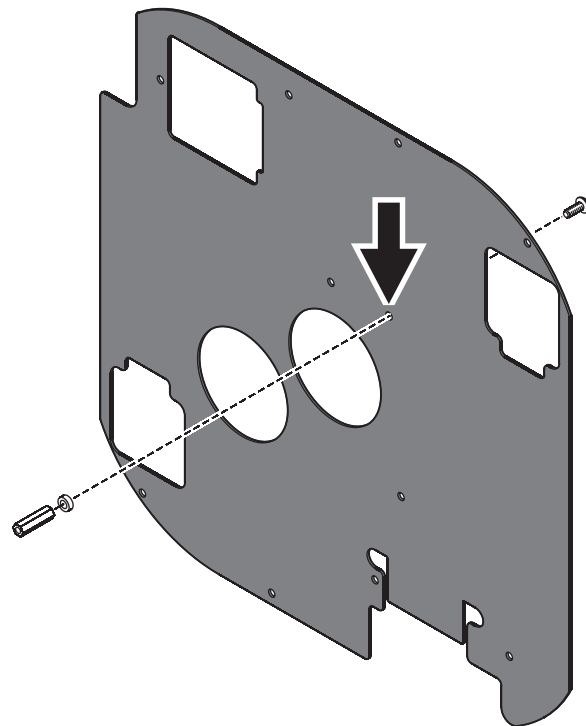

Figure 20

24. See Figure 21. Disconnect the color wheel motor (the largest motor on the module) at its multi-connector.

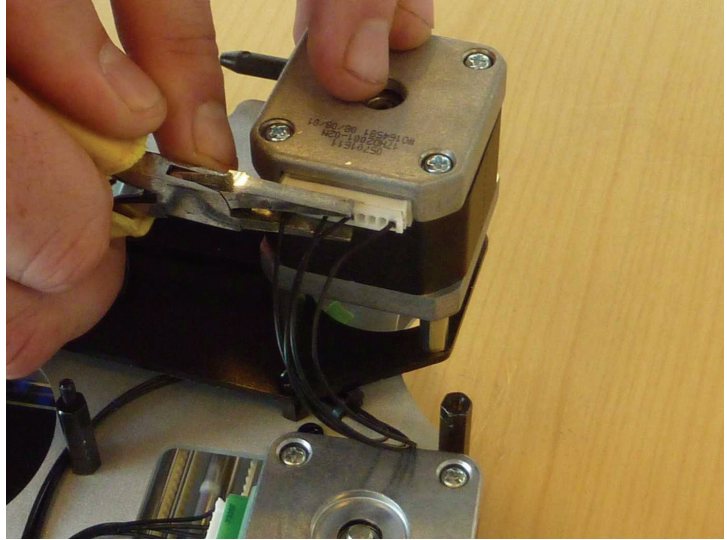

Figure 21

25. See Figure 22. Put the new spill limiter plate into position, passing leads and connectors carefully through apertures and checking that no leads are trapped.
26. Re-using the six panhead Torx M3 x 10 screws you removed in step 21, plus one of the similar screws you removed in step 4, fasten the outside of the spill limiter plate to the pillar bolts under the plate as shown in Figure 22.
27. Reconnect the color wheel motor you disconnected in step 24.

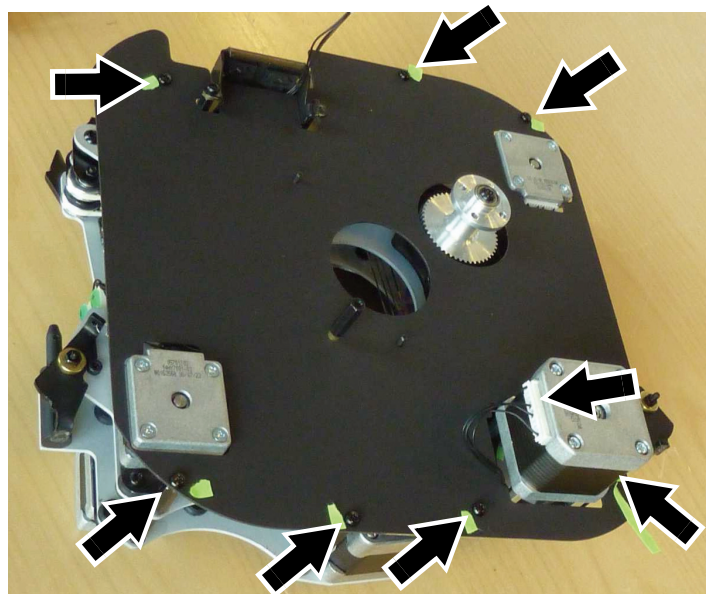

Figure 22

28. See Figure 23. Inserting 3 x spacers (P/N 08261011), install the remaining three of the ten male/female pillars (P/N 08053814) supplied in the kit, using a 5.5 mm open-ended wrench to hold the pillars on the other side of the spill limiter plate.

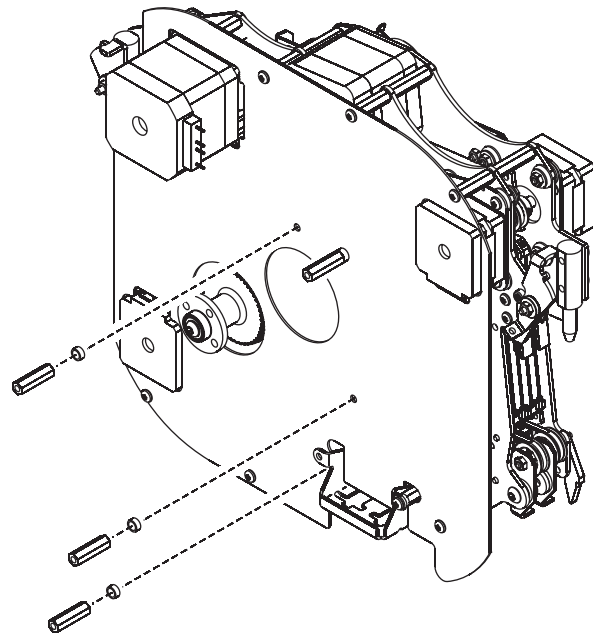

Figure 23

29. See Figure 24. Fasten the new color wheel onto its flange in any position where the screw holes line up using four M4 x 10 Taptite screws. Do not damage the filters while applying force to cut the threads in the color wheel flange.

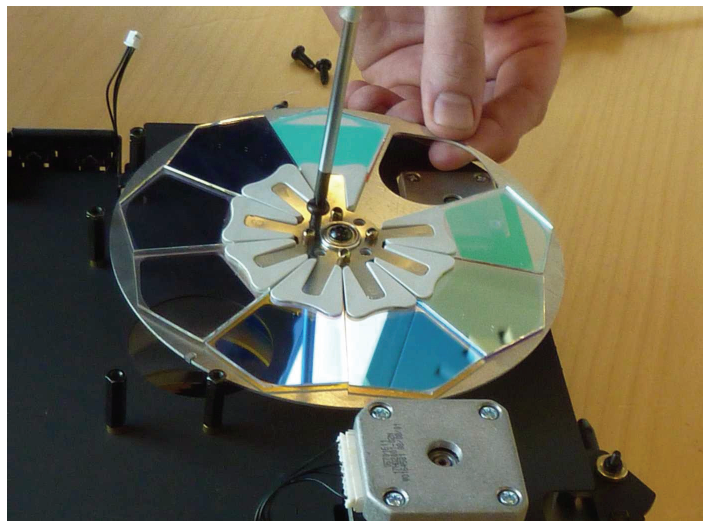

Figure 24

30. Fasten the new aperture plate onto its 4 pillars as shown in Figure 25.

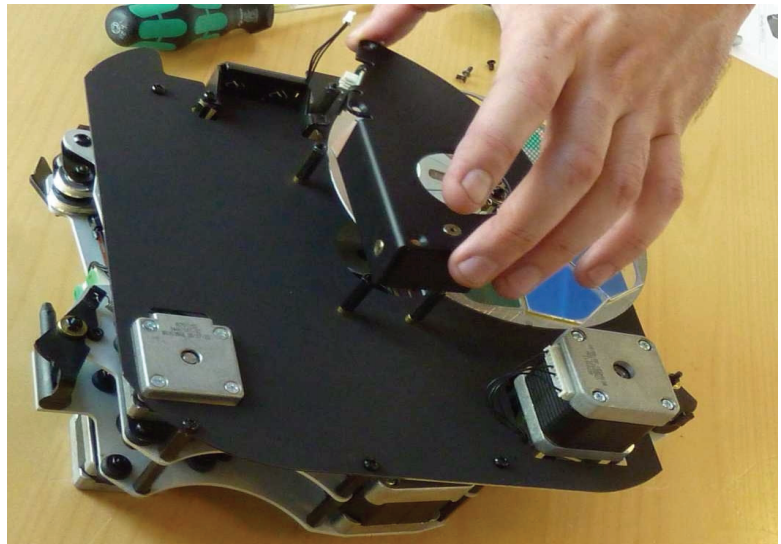

Figure 25

31. See Figure 26. Connect the multiconnector to the sensor PCB on the new aperture plate.
32. Reinstall the effects module in the head and replace all covers before reapplying power.

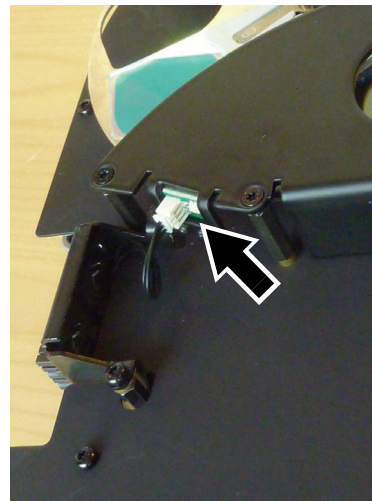

Figure 26

Product information

For other information about the MAC 700 Wash, please refer to the user manual originally supplied with the fixture. The manual is also available for download and online specifications for the MAC 700 Wash can be viewed in the Product Support area of the Martin website at <http://www.martin.com>.

Martin[®]

Martin Professional A/S • Olof Palmes Allé 18 • 8200 Aarhus N • Denmark
Tel: +45 8740 0000 • Fax +45 8740 0010 • www.martin.com