

## Mac Viper head air filter replacement

---

November 2014

### Safety precautions

- **Read the Safety and Installation Manual supplied with the MAC Viper and available for download from [www.martin.com](http://www.martin.com) before replacing head air filters.**
- **Observe all warnings printed on the product and in the Safety and Installation Manual.**
- **Isolate the product from power and allow it to cool for 5 minutes before servicing it.**

We have introduced new, more effective head air filters for the MAC Viper series. The finer filtration of the new filters provides a cleaner supply of cool air, improving the product's performance and reducing service downtime while optical components are cleaned.

The new-type air filters cannot be cleaned. When a filter becomes dirty and airflow is significantly reduced, you must replace the filter with a new item: P/N: 20800270 'Air filter - head'.

We have tried to keep the price of filters down to a reasonable level, and the cost of replacing filters is much lower than the cost of replacing components that have been subjected to excess heat. Besides minimizing thermal stresses, making sure that a fixture has clean air filters will also ensure the quietest possible operation.

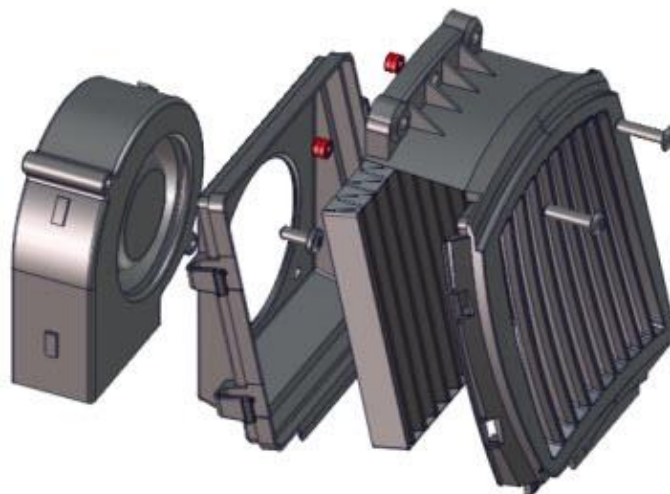

**New air filter assembly**

To check whether you need to replace an air filter, hold it up in front of a household light source such as a ceiling light and check whether you are able to see through it. Decide whether the filter requires replacement by comparing it with the example photos on the next page. If you are in any doubt about the condition of a filter, replace it.

Filter replacement intervals depend on operating conditions and vary widely, so check the condition of the head air filters frequently.

Replace both head air filters at the same time.

Respect the environment when disposing of used filters. Like household dust found in vacuum cleaners, air filter dust can contain particles that may cause an allergic reaction, asthma and/or eczema.

If you are in any doubt about how to install, operate or service a Martin™ product safely, contact Martin™ for advice. If necessary, contact the Martin™ 24-hour emergency hotline available worldwide on +45 87400000 or in the USA on 1-888-TECH-180.

## Example air filters

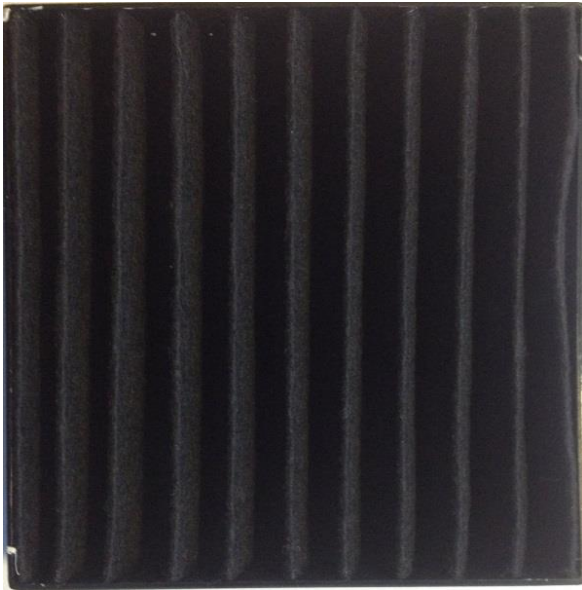

**Clean air filter**

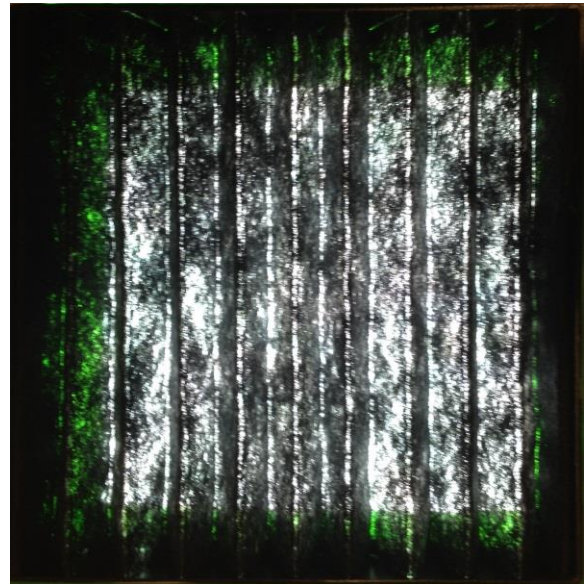

**Clean air filter with backlight**



**Dirty air filter –  
must be replaced**

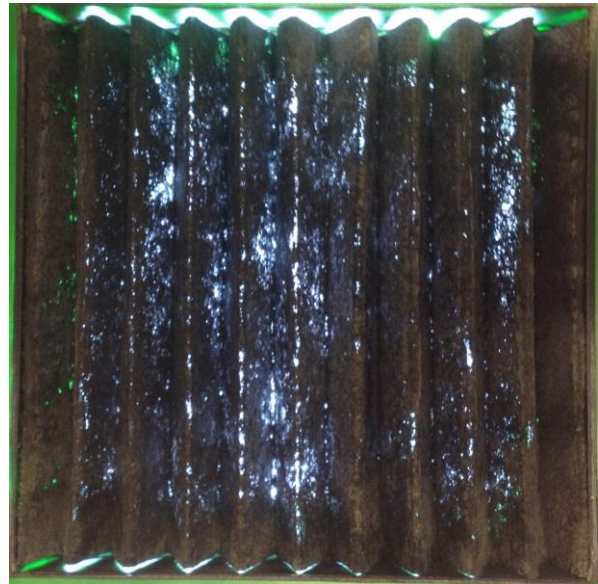

**Dirty air filter with backlight –  
must be replaced**

**Martin**<sup>®</sup>  
by HARMAN

www.martin.com • Olof Palmes Allé 18 • DK-8200 Aarhus N • Denmark  
Tel. (+45) 8740 0000 • Fax (+45) 8740 0010

©2014 Martin Professional ApS. Information subject to change without notice. Martin Professional and all affiliated companies disclaim liability for any injury, damage, direct or indirect loss, consequential or economic loss or any other loss occasioned by the use of, inability to use or reliance on the information contained in this document. The Martin logo, the Martin name and all other trademarks in this document pertaining to services or products by Martin Professional or its affiliates and subsidiaries are trademarks owned or licensed by Martin Professional or its affiliates or subsidiaries.