

USER GUIDE

VERSION 1.5

Jem

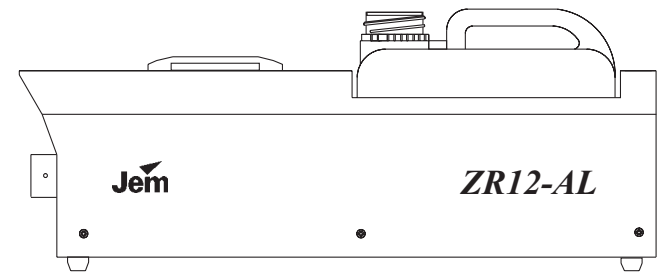

ZR12-AL

MARTIN MANUFACTURING (UK) PLC

Jem

MANUFACTURED BY
MARTIN MANUFACTURING (UK) PLC
BELVOIR WAY,
FAIRFIELD INDUSTRIAL ESTATE,
LOUTH, LINCOLNSHIRE, LN11 0LQ
UK

TEL:+44(0)1507 604399 FAX:+44(0)1507 601956

Fluids Suitable For This Machine:



*Note:
The JEM warranty will be void if any fluid other than JEM approved fluid is used. If other fluids are used there could be serious damage to the machine and the fluid may not of been tested for use in public areas.*

How To Contact Us

*Address: Martin Manufacturing (uk) Plc
Belvoir Way,
Fairfield Industrial Estate,
Louth, Lincolnshire, LN11 0LQ
UK*

Telephone: +44 (0) 1507 604399

Fax: +44 (0) 1507 601956

Email: jem@martin.dk

Website: [Http://www.jemsmoke.com/](http://www.jemsmoke.com/)

Notes

User Guide Index

Introduction

Safety

Machine Layout

Getting Started

Using The Remote Control

Using The Analogue Link

The ZR12-AL Ducting Kit

Trouble Shooting

How To Contact Us

Note:

Martin Manufacturing (UK) reserves the right to modify or change the specification of this product without prior notice.

No part of this publication shall be copied without permission

© Martin Manufacturing (UK). 1999

Introduction

The ZR12 is the first small JEM machine to feature the new “AL” Analogue Link technology. This allows units to be linked together and controlled from one JEM Multi Function Controller. The ZR12 is also fitted with a 1 kW heat exchanger which guarantees the maximum output from this size of vaporizing system.

The ZR12 uses the ‘DTP’ overheat protection device for the best possible overheat protection. This was first used on the JEM TECHNO-FOG with great success. A 2.5 Litre fluid container is supplied to minimize the need for refilling.

A multi-function controller enables the user to operate the machine manually using the ‘FOG’ button or set the timer for automatic operation. The timer has a new feature called x8 mode, this allows the timer values to be adjusted from x1 to x8 giving the user more variation in the timer settings. There is also a ducting kit for applications where the effect is needed in an area away from the ZR12.

Features:

Analogue Link facility

High Power Piston Pump

Multifunction Remote Controller

“DTP” Safety System

Pump Ramping For Continuous Output

2.5 Litre Fluid Capacity

SMD Electronics

Low Noise Soft Start Pumping

Heavy Duty Construction

Notes

Trouble Shooting

<u>SYMPTOM</u>	<u>CAUSE</u>	<u>CURE</u>
The mains switch does not light when I switch on.	No power connected.	Check power is connected.
The power LED does not light on the remote control.	Fuse on main PCB blown. Remote control not connected.	Check fuse on Main PCB. Check connection of remote control.
The ready LED does not light. even after 15 minutes.	Stand-by button is not on. Sensor fault	Check stand-by button Contact JEM or your Distributor.
No smoke output when fog button is pressed (ready LED is lit).	The output knob is not set correctly No fluid in fluid container.	Turn output knob fully clockwise. Replace fluid container.
The effect is not lasting long enough.	Fluid is the wrong grade.	Choose a longer lasting fluid (SP)

Safety

Always use a JEM approved fluid, other fluids could be dangerous and could cause damage to the machine.

Always check the voltage is correct for use with the machine, the voltage setting is printed on the serial label.

Always read the user guide before operating the machine, smoke machines need to be operated carefully to avoid risk.

Never touch the nozzle at the front of the machine, the nozzle can stay hot for up to 10 hours.

Do not remove the cover or attempt to repair a faulty machine, an authorized JEM dealer should be contacted in the event of a faulty machine.

Always use smoke machines in well ventilated areas, over use could affect sufferers of asthma or other chest conditions.

Do not use the machine if there is a faulty mains lead or plug, this could be dangerous.

Never point the output directly at peoples heads, this is a high power smoke machine.

Always use approved accessories with this machine.

Do not spill fluid over the machine, if fluid is spilt clean with clean water and contact an approved JEM dealer for advice.

Mains Lead Wiring Instructions

Brown = Live
Blue = Neutral
Green/Yelllow = Earth

Note! This Appliance must be earthed

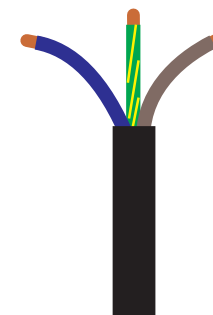

Machine Layout

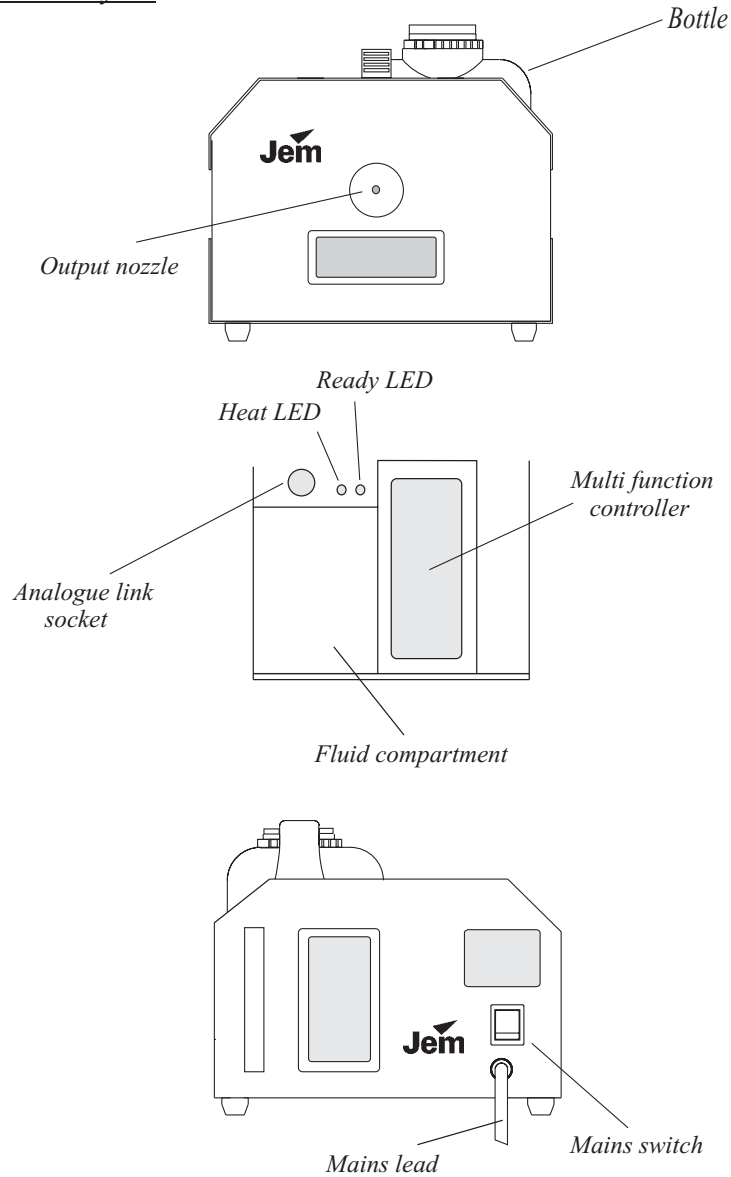

ZR12-AL Ducting Kit

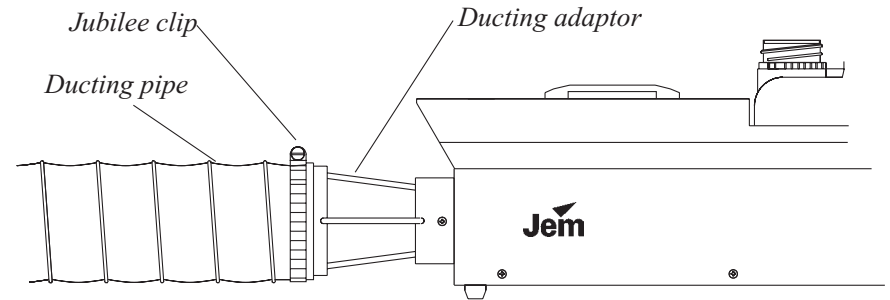

The JEM ZR12-AL ducting kit enables the user to duct the smoke from the machine to an area where the effect is required. This is done by using the JEM ducting adaptor and a length of 100 mm (4") ducting pipe. The length can be anything from a couple of metres up to 20 metres or further. There are one or two things to beware of when using smoke machines with ducting. Firstly if there are bends to redirect the smoke they could cause condensation to form. Also an air space must be provided between the output of the machine and the ducting adaptor.

NOTE! Always use the recommended ducting adaptor and ducting pipe, others may cause damage to the machine.

Using The Analogue Link

The ZR12-AL has the ability to connect machines together using a Din lead and then operating all of the machines with one controller. This is ideal when there is a need for lots of smoke and there is no DMX to operate the machines. Simply remove the controllers from all but one of the machines and then connect a Din lead (5 pin) from the slave socket of the first machine (the one with the controller) to the next machine's remote socket, and then from that machine's slave to the next machine's remote socket. This can be done from two up to ten machines maximum. All of the machines will operate with the same output and timer settings as the first machine.

Wiring of Din

- Pin 1 - NA
- Pin 2 - Gnd
- Pin 3 - NA
- Pin 4 - NA
- Pin 5 - 0 - 10v

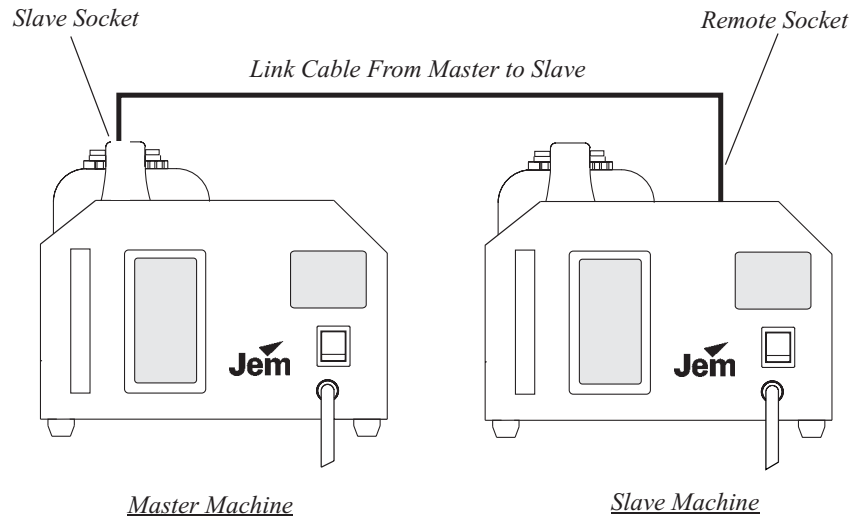

Getting Started

Once you have selected the best position for the ZR12-AL you can begin to use the machine. First check the power supply you have is correct for the machine, if it is you can connect to the power supply and switch the mains switch on at the rear of the machine. This will light when switched on, now de-press the grey "stand-by" button, the machine will now heat up which takes around 7 - 8 minutes. While it heats up you should check the level in the fluid container, the container can hold up to 2.5 litres of fluid.

NOTE! Do not allow the ZR12-AL to run out of fluid. Serious damage may occur if the machine is operated when no fluid is connected.

When the machine has reached working temperature the green "ready" LED will light on the top of the machine and the machine can now be operated. Check the "output" knob is turned fully clockwise (maximum) and press and hold the red "fog" button. The fluid pump will start operating and if the machine has a new container of fluid the fluid will take a few seconds to reach the pump. When the pump has primed smoke will be visible. The output can now be set to the desired level by turning the "output" knob. The timer may be activated or you can simply use the "FOG" button when smoke is required.

Once you have finished using the machine you should de-press the "stand-by" button and then turn the mains switch off. If any problems occur when operating the ZR12-AL please refer to the trouble shooting guide..

Using The Remote Control

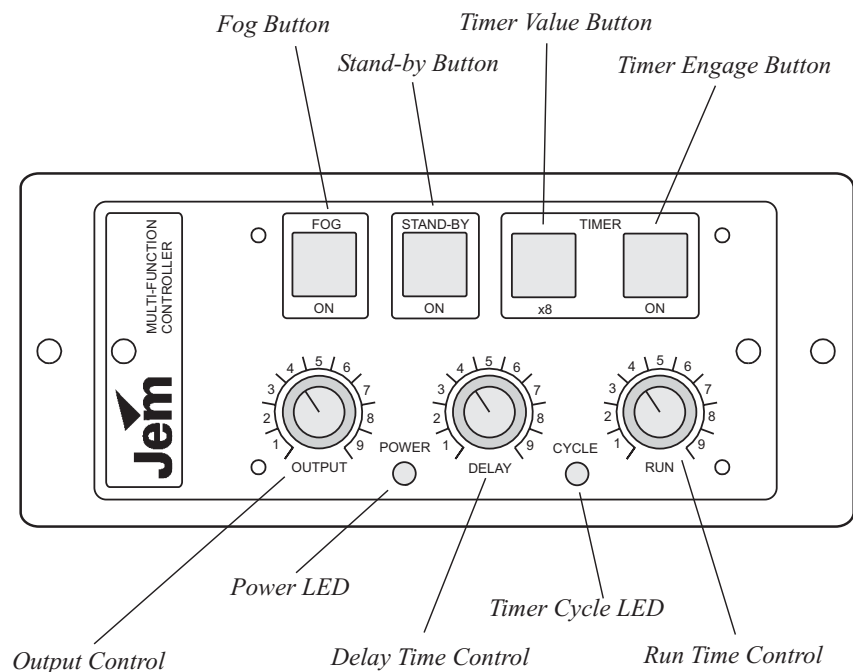

The ZR12-AL comes with a comprehensive controller that allows the user to manually fire the machine or set a well featured timer to operate the machine. When the “ready” LED is lit on the top of the machine, the remote becomes functional and the “Fog” button will operate the machine when pressed. Sometimes a pre-determined amount of smoke is needed and the ZR12-AL remote has a timer that will operate over a wide range of time periods. The x8 timer value gives even greater flexibility when a longer delay and run time are needed.

Functions

FOG BUTTON: Will when the machine has reached operating temperature fire the machine when pressed and held.
STAND-BY BUTTON: This turns the machines electronics on and off.
TIMER VALUE BUTTON: When the timer is being used, the timer values can be adjusted by a factor of 8, i.e. a 5 second minimum run time becomes 40 seconds & a 10 second delay time becomes 1 minute 20 seconds.
TIMER ENGAGE: This will engage the timer to fire the machine according to the present settings.
OUTPUT CONTROL: Turning this knob clockwise will increase the output of the machine, if turned fully anti-clockwise there will be no output.
DELAY TIME CONTROL: This will adjust the amount of time the machine waits between operating when the timer is engaged.
RUN TIME CONTROL: This will adjust the time the machine will operate for when the timer is engaged.
POWER LED: This LED will light when the machine is switched on
CYCLE LED: This LED will light when the timer is engaged and the machine is operating.

Timer Values

Run Time: X1 mode

Minimum = 2 seconds
 Maximum = 18 seconds

Run Time: X8 mode

Minimum = 16 seconds
 Maximum = 2 minutes 24 seconds

Delay Time: X1 mode

Minimum = 2 seconds
 Maximum = 18 seconds

Delay Time: X8 mode

Minimum = 16 seconds
 Maximum = 2 minutes 24 seconds

An extension lead is available from JEM for using the controller out of the machine.