

# THRILL Compact PAR 64 LED



## User Guide



**WARNING!**  
Read the *Safety and Installation Guide* supplied with this product before installing or using this product.

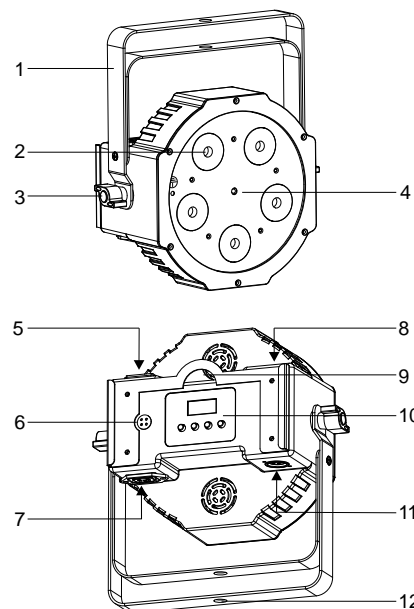

### Fixture overview

1	Multi-function bracket	7	AC Mains out
2	LED emitters	8	DMX In
3	Hand wheel	9	Secondary attachment point
4	IR receiver	10	User interface
5	AC Mains in	11	DMX Out
6	Microphone	12	Clamp attachment point

### Using the control menu

The control menu is shown below. To access the menu, press the MENU button. Scroll through options with the ▼ (down) and ▲ (up) buttons. Press ENTER to select an option. To return to a higher level in the menu, press MENU. To exit the menu, press and hold MENU or wait a few seconds. The default menu settings are shown in **bold**.



Menu	Sub-menu	Explanation
<i>Addr</i>	<b>001-507</b>	Set DMX address
<i>Chan</i>	<b>6 Ch</b>	Select 6-channel DMX mode
	<b>9 Ch</b>	Select 9-channel DMX mode
<i>MSL</i>	<b>SLR</b>	Set Client fixtures
	<b>MSL</b>	Set Master fixture
<i>Show</i>	<b>Sh-</b>	
	<b>oFF</b>	Show mode off
	<b>Sh 1</b>	Select preprogrammed show.
	<b>Sh 2</b>	
	<b>Sh 3</b>	
	<b>Sh 4</b>	
<b>SPEd</b>	Select auto-trigger speed from 1-8	
<i>Sound</i>	<b>oFF - on</b>	Toggle sound activation on/off
<i>Sens</i>	<b>1-100</b>	Set microphone sensitivity
<i>dPH</i>	<b>bLCH</b>	Black out if DMX lost
	<b>SHoU</b>	Run stand-alone show mode
	<b>HoLd</b>	Hold last values if no DMX
<i>diSP</i>	<b>LEd on - oFF</b>	Toggle display on/off
	<b>inur YES</b>	Inverted/normal display
<i>MANU</i>	<b>Stro</b>	Manual mode, select effect and set level from 0 to 255.
	<b>di PH</b>	
	<b>rEd</b>	
	<b>gR EE</b>	
	<b>bLUe</b>	
	<b>Amber</b>	
	<b>UV</b>	
<b>CoN</b>		
<i>TEST</i>		Run fixture test routine
<i>Hours</i>		Readout fixture hours
<i>ver</i>		Readout firmware version
<i>rst</i>	<b>YES</b>	Reset to default values

### DMX mode operation and settings

#### DMX channel mode (*Chan*)

The Compact PAR 64 LED has 2 DMX modes that use 6 or 9 channels. The 6-channel mode provides color mixing with 0-100% control of each color: red, blue green, amber, white, and UV.

In 9-channel mode, the Compact PAR 64 LED provides color mixing, 36 popular preset colors, full-range dimming, and strobe effects. The DMX command tables list all functions and their values.

To set 6-channel or 9-channel DMX mode:

1. Press MENU to enter the control menu.
2. Scroll to *Chan*. Press ENTER to confirm.
3. Scroll to the desired mode: **6 Ch** or **9 Ch**.
4. Press ENTER to save your selection.

#### DMX address (*Addr*)

A DMX controller uses either 6 or 9 DMX channels to control the Compact PAR 64 LED. The DMX address is the first channel used. If fixtures are set to 6-channel DMX mode and the first fixture's DMX address is set to 1, then it receives instructions on DMX channels 1, 2, 3, 4, 5, and 6. The next fixture could then be set to a DMX address of 7.

For independent control, each fixture must have its own unique control channels. For symmetric control, identical fixtures can be set to the same DMX address.

Assign an address for the fixture on the DMX controller. Then set that address on the Compact PAR 64 LED as follows:

1. Press MENU to enter the control menu.
2. Scroll to *Addr*. Press ENTER.
3. Scroll to the address that you assigned to the fixture.
4. Press ENTER to save the address.

#### DMX state (*dPH*)

The fixture runs in DMX mode whenever it receives DMX signals. When there is no DMX signal, the fixture can be set to run in Show Mode (**SHoU**), black out (**bLCH**), or hold the last DMX values received (**HoLd**). **For Show Mode operation, DMX state must be set to SHoU.**

To select behavior when there is no DMX signal:

1. Select *dPH* in the control menu and press ENTER.
2. Select the desired behavior: **SHoU**, **bLCH**, or **HoLd**.
3. Press ENTER to save your selection.

#### DMX commands, 6-Channel Mode

Ch.	Value	Function
1	0-255	Red 0-100%
2	0-255	Green 0-100%
3	0-255	Blue 0-100%
4	0-255	Amber 0-100%
5	0-255	White 0-100%
6	0-255	UV 0-100%

#### DMX commands, 9-Channel Mode

Ch.	Value	Function	
1	0-7	<b>Shutter</b>	
	8-15	Closed	
	16-131	Open	
	132-139	Strobe, slow to fast	
	140-181	Open	
	182-189	Pulse, fast close/slow open	
	190-231	Open	
	232-239	Pulse, slow close/fast open	
	240-247	Open	
	248-255	Random strobe	
	2	0-255	<b>Dimmer</b> , intensity 0-100%
	3	0-255	<b>Red</b> , intensity 0-100%
	4	0-255	<b>Green</b> , intensity 0-100%
5	0-255	<b>Blue</b> , intensity 0-100%	
6	0-255	<b>Amber</b> , 0-100%	
7	0-255	<b>White</b> , 0-100%	
8	0-255	<b>UV</b> , 0-100%	
9	0-10	<b>Color presets</b>	
	11-15	Off	
	16-20	Color 1	
	21-25	Color 2	
	26-30	Color 3	
	31-35	Color 4	
	36-40	Color 5	
	41-45	Color 6	
	46-50	Color 7	
	51-55	Color 8	
	56-60	Color 9	
	61-65	Color 10	
	66-70	Color 11	
	71-75	Color 12	
	76-80	Color 13	
	81-85	Color 14	
	86-90	Color 15	
	91-95	Color 16	
	96-100	Color 17	
	101-105	Color 18	
	106-110	Color 19	
	111-115	Color 20	
	116-120	Color 21	
	121-125	Color 22	
	126-130	Color 23	
	131-135	Color 24	
	136-140	Color 25	
141-145	Color 26		
146-150	Color 27		
		Color 28	

Ch.	Value	Function
	151-155	Color 29
	156-160	Color 30
	161-165	Color 31
	166-170	Color 32
	171-175	Color 33
	176-180	Color 34
	181-185	Color 35
	186-190	Color 36
	191-192	Off (no preset color)
	193-214	Continuous color scroll, fast to slow
	215-221	Color scroll stop
	222-243	Reverse color scroll, slow to fast
	244-247	Random colors, fast
	248-251	Random colors, medium
	252-255	Random colors, slow

### Show mode operation and settings

Show mode lets you run a standalone light show without a DMX controller. Shows can be triggered by sound, or automatically triggered at eight speeds.

To enable Show Mode operation, set the DMX state setting to **SHoU**.

#### Show selection (*Show*)

Four shows are available. To select a preprogrammed show:

1. Press MENU to enter the control menu.
2. Scroll to *Show* and press ENTER.
3. Select **Sh-** and press ENTER.
4. Select a show from **Sh 1** to **Sh 4**, or select **oFF** to disable Show Mode. Press ENTER.

#### Music trigger (*Sound* and *Sens*)

The fixture's built-in microphone triggers effect and color changes in sync with music. To enable sound activation:

1. Select *Sound* in the control menu and press ENTER.
2. Select **on** to enable sound activation or **oFF** to disable it.
3. Press ENTER to save your selection.

To adjust microphone sensitivity for the volume of the music:

1. Turn on the music source and set it to the desired volume.
2. Select *Sens* in the control menu and press ENTER.
3. Press ▼ or ▲ to decrease or increase the sensitivity level.
4. When the fixture responds as desired, press ENTER.

#### Auto trigger speed (*SPEd*)

To use auto trigger in Show Mode:

1. Turn off sound activation as described above.
2. Select *Show* in the control menu and press ENTER.
3. Scroll to *SPEd*. Press ENTER.
4. Select a trigger speed from 1 (slow) to 8 (fast). Press ENTER.

### Master/client mode operation and settings

Up to 32 Compact PAR 64 LEDs can be linked in a chain and set to master/client operation, where the first Compact PAR 64 LED in the chain is set to operate as the "master" that controls the others.

This provides synchronized operation without a controller. Note: **There must be no more than one master in the chain.** Set all other connected fixtures to operate as clients.

To set the first fixture to be the master:

1. Enter the control menu and scroll to *MSL*. Press ENTER.
2. Scroll to *MSL*. Press ENTER.
3. Set show mode options as described above.

To set other fixtures as clients:

1. Enter the control menu and scroll to *MSL*. Press ENTER.
2. Scroll to *MSL*. Press ENTER.

Link the master and client fixtures in a chain, using DMX cable to connect each fixture's DMX OUT socket to the next fixture's DMX IN socket as described in the Safety and Installation Guide.

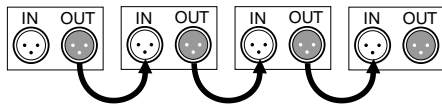

## Other settings

### LED display on/off (LEd)

To set the control panel's LED display to be on all the time, or to automatically sleep when not in use:

1. Select *d SP* in the control menu and press ENTER.
2. Select *LEd* and press ENTER.
3. Select *on* (display on) or *oFF* (display off when not in use).
4. Press ENTER to save your selection.

### LCD display inversion (Inur)

To invert the control panel's LED display for easier reading:

1. Select *d SP* in the control menu and press ENTER.
2. Select *Inur* and press ENTER.
3. Select *YES* to invert the display.
4. Press ENTER to save your selection or MENU to escape.

### Manual mode (Mnu)

Effects can be set from the control panel. To keep the effect settings, do not exit the menu.

See the 9-channel mode DMX table for command values. To set effects from the control panel:

1. Enter the control menu and scroll to *Mnu*. Press ENTER.
2. Scroll to the color or effect to adjust. Press ENTER.
3. Press  $\blacktriangledown$  or  $\blacktriangle$  to specify a value from 0 to 255 for the effect.
4. Press ENTER to set the effect.
5. Press MENU and repeat for the other colors or effects.

### Auto test (tEst)

To test all of the fixture functions select *tEst* and press ENTER. Press MENU to exit the test routine.

### Fixture readouts

Hours: To display the fixture's total operating hours select *Fhr5* and press ENTER. Press MENU to exit.

Firmware: To display the firmware version number, select *vEr* and press ENTER. Press MENU to exit.

### Settings reset

To return all user settings to the factory default values, select *rSt* in the control menu. Press ENTER to confirm or MENU to escape.

## Remote control operation

The remote control works with all Compact PAR 64 LED fixtures within range.

To operate the Compact PAR 64 LED with the remote control:

1. Verify that the fixture is not connected to a DMX controller.
2. Press MENU to enter the control menu.
3. Scroll to *ShDU* and press ENTER.
4. Select *Sh\_* and press ENTER.
5. Select *oFF* to disable Show Mode. Press ENTER.
6. To execute commands, point the remote control towards the front of the fixture and the press corresponding button. See table below.

## Remote Control Commands

Button	Function
BL	Toggle LEDs on/off
SP	Adjust speed (4 levels). Use with JU, FA, and SU.
	Dimming (4 levels)
FL	Strobe (4 speeds)
R	Adjust Red intensity (off, 4 levels)
G	Adjust Green intensity (off, 4 levels)
B	Adjust Blue intensity (off, 4 levels)
W	Adjust White intensity (off, 4 levels)
A	Adjust Amber intensity (off, 4 levels)
UV	Adjust UV intensity (off, 4 levels)
JU	Jump Mode – snaps thru pre-programmed colors. Adjust speed with SP.
FA	Fade Mode – Fades thru pre-programmed colors. Adjust speed with SP.
AU	Auto-trigger mode.
SU	Music-triggered Sound Mode. Adjust sensitivity level with SP.
CM+	Next color
CM-	Previous color

### Replacing the wireless remote control battery

The wireless remote control uses a single CR 2025 coin/button/cell 3 V lithium battery. To replace the battery:

1. Depress the battery tray lock on the reverse of the remote control and slide out the battery tray. Remove the old battery.
2. Insert a fresh battery with the positive terminal towards the back of the remote. A diagram on the remote control indicates the correct orientation.
3. Align the battery tray to the remote control and re-insert the tray ensuring that the locking mechanism is secure.
4. Dispose of used batteries in accordance with local regulations.

If the coin/button/cell battery compartment does not close securely, stop using the product and keep away from children and animals. Contact Martin Professional for service and support.

## Troubleshooting

Symptom	Potential Causes	Remedies
No light from fixture, control panel dead	Power supply issue such as blown fuse, faulty connector or damaged cable	Ensure that the mains supply is connected and supplying power to the fixture
		Check all power connections and cables
		Check and if necessary replace the fuse
Fixture does not respond to DMX control	Fault in the DMX network due to connector or cable damage, incorrect DMX addressing, or signal interference	Ensure that fixture's DMX address matches address set on DMX control device
		Check DMX cables and connections
		Ensure that DMX link is terminated
		Reduce number of fixtures on DMX link
		Attempt to control the fixture with another DMX control device
Fixture does not respond in Show Mode	Fixture set to run as client	Change master/client setting master
	Sound trigger disabled	Enable sound trigger
	Show Mode disabled or no show selected	Change DMX state setting to Show Mode Select a show
	Microphone sensitivity too low	Increase sensitivity <i>SEt in9</i>
Fixtures don't respond in master/client mode	Fixture receiving multiple control signals	Disconnect or turn off DMX controller Verify there is only one fixture master fixture
	No master fixture	Set first fixture in chain as master
Fixture does not respond to remote control	Remote control out of range	Move closer to fixture
	Battery exhausted	Replace battery
	Incorrect menu settings	Verify show mode is disabled ( <i>Sh- = oFF</i> )

Information subject to change without notice. HARMAN Professional Inc. disclaims liability for any injury, damage, direct or indirect loss, consequential or economic loss or any other loss occasioned by the use of, inability to use or reliance on the information contained in this document.

©2017 HARMAN Professional Inc. All rights reserved. Martin® is a registered trademark of HARMAN Professional Inc. registered in the United States and other countries. Features, specifications, and appearance are subject to change without notice.

HARMAN Professional Inc.  
8500 Balboa Boulevard • Northridge, CA, USA • 91329

[www.martin.com](http://www.martin.com)

Document revision: B