

Ego 01
Ego 02
Ego 03
Logo Projector
user manual

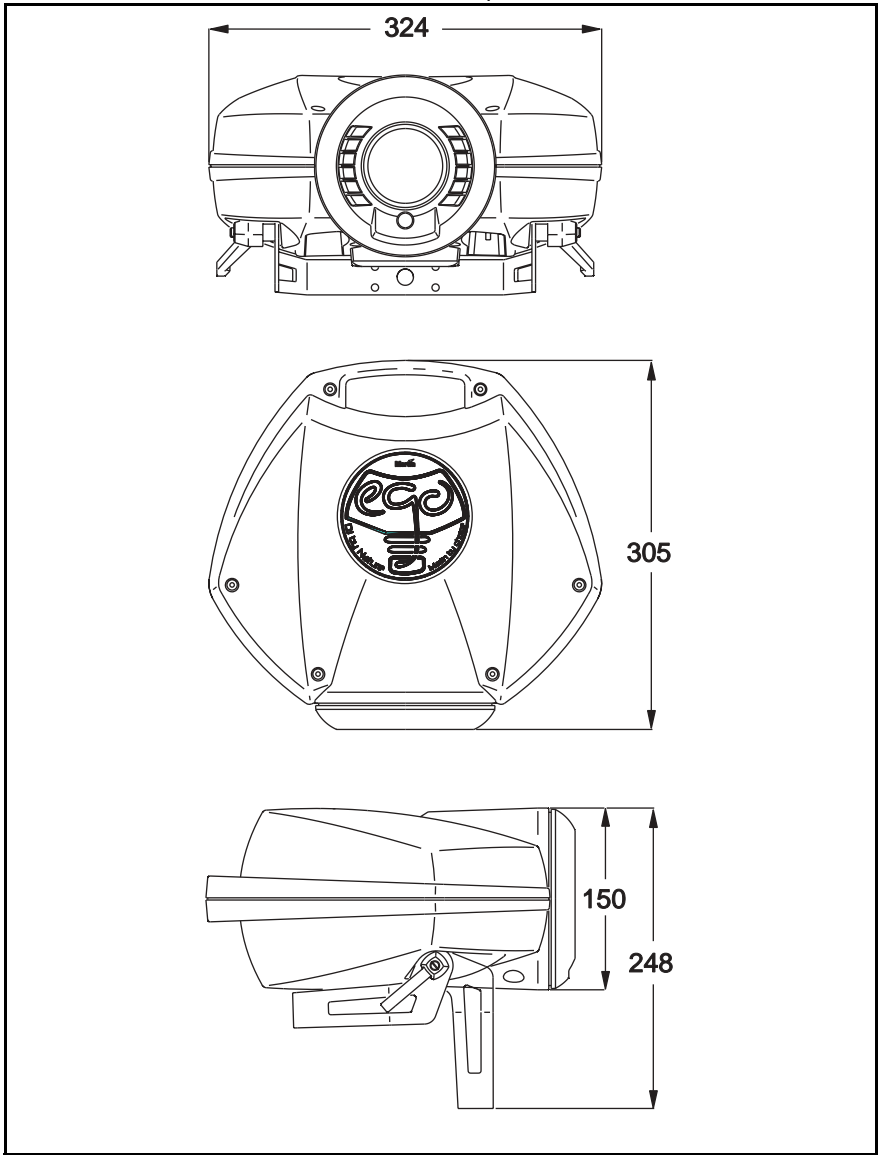

Measurements are expressed in millimeters.



© 2002-2004 Martin Professional A/S, Denmark.

All rights reserved. No part of this manual may be reproduced, in any form or by any means, without permission in writing from Martin Professional A/S, Denmark.

Printed in Denmark.

P/N 35000109, Rev. H

CONTENTS

Introduction	4
Ego 01 / Logo Projector	4
Ego 02	4
Ego 03	5
Safety information	5
Unpacking	6
AC power	7
Installing a plug on the mains lead	7
Installation	8
Mounting	8
Linking multiple Egos for simultaneous control	10
Operation	11
Setting the trig mode	11
Adjusting the effects	11
Focusing the Ego	12
Selecting the gobo on an Ego 2	12
Operation with the optional remote control	13
Basic service	14
Cleaning	14
Lamp maintenance	15
Fuses	16
Gobo replacement or removal (Ego 2)	17
Firmware updates	17
Troubleshooting	18
Specifications	19

INTRODUCTION

1

Thank you for selecting a Martin Ego. The Ego series features 250 watt flower effects with sharp projection quality optics in a moulded composite-plastic casing. They incorporate a 250-watt halogen lamp and a precise focus adjustment that produces crisp projections.

Variable behavior tuning, by adjusting the dynamic, allows you to modify the aggressiveness of the effect in relationship to the music - relaxed, intermediate or quick. The Ego operates in either automatic or music-activated trigger mode.

A convenient handle and lens protection ring make for easy transport and handling. A remote control is also available that enables the simultaneous control of multiple Ego fixtures.

EGO 01 / LOGO PROJECTOR

The Ego 01 provides a flower effect with a range of gobos and colors on a single effect wheel. In addition to variable behavior tuning, effect wheel and mirror dish rotation speeds are controllable.

The Logo Projector is the same as the Ego 01, but it is primarily used to project images around a specific theme.

EGO 02

The Ego 02 features an overlapping color wheel system offering more than 200 color combinations and a manually selectable image effect (etched gobo or textured glass gobo pattern). An interchangeable gobo slot is available so that you can incorporate your own custom patterns or accessories. In addition to variable behavior tuning, the rotation speeds of the color wheels and mirror dish are also controllable.

EGO 03

The Ego 03 is a kaleidoscopic effect with a range of gobo and color combinations on a single effect wheel that are projected onto a series of mirrored tunnels. In addition to variable behavior tuning, effect wheel and mirrored-tunnel rotation speeds are controllable.

SAFETY INFORMATION

Warning! This product is not for household use. It presents risks of lethal or severe injury due to fire and heat, electric shock, and falls.

Read this manual before powering or installing the fixture, follow the safety precautions listed below and observe all warnings in this manual and printed on the fixture. If you have questions about how to operate the fixture safely, please contact a Martin distributor for assistance. Refer any service operation not described in this manual to a qualified technician. Do not modify the fixture or install other than genuine Martin accessories and upgrade kits.

Avoiding electric shocks

- Disconnect the fixture from AC power before removing or installing the lamp, fuses, or any part, and when not in use.
- Always ground (earth) the fixture electrically.
- Use only a source of AC power that complies with local building and electrical codes and has both overload and ground-fault protection.
- Do not expose the fixture to rain or moisture.
- Refer all service to a qualified technician.
- Never operate the fixture with missing or damaged lenses and/or covers.

Protecting yourself and others from burns and fire

- Never attempt to bypass the thermostatic switch or fuses. Always replace defective fuses with ones of the specified type and rating.
- Ensure that the air flow through fans and vents is free and unobstructed.
- Keep all combustible materials (for example fabric, wood, paper) at least 0.1 meters (4 inches) away from the fixture. Keep flammable materials well away from the fixture.
- Do not illuminate surfaces within 0.3 meters (12 inches) of the fixture.

- Provide a minimum clearance of 0.1 meters (4 inches) around fans and air vents.
- Replace the lamp if it becomes defective or worn out, or before usage exceeds the maximum service life. When replacing the lamp, allow the fixture to cool for at least 5 minutes before opening the fixture or removing the lamp. It can take up to 15 minutes for the fixture to cool completely.
- Never place filters or other materials over the lens or mirror drum.
- The exterior of the fixture can become hot. Allow the fixture to cool for at least 5 minutes before handling.
- Do not operate the fixture if the ambient temperature (T_a) exceeds 40° C (104° F).
- Do not stare directly into the light.
- Never operate the fixture without all lenses and covers installed: an unshielded lamp emits dangerous UV radiation that can cause burns and eye damage.

Preventing injuries due to falls

- When suspending the fixture above ground level, verify that the structure can hold at least 10 times the weight of all installed devices.
- Verify that all external covers and rigging hardware are securely fastened and use an approved means of secondary attachment such as a safety cable.
- Block access below the work area whenever installing or removing the fixture.

UNPACKING

The packing material is carefully designed to protect the fixture during shipment - always use it to transport the fixture.

The Ego comes with the following:

- 3-meter, 3-wire IEC power cable
- User manual

AC POWER

2

The Ego has an auto-ranging power supply that can operate in the following voltage ranges at 50-60 Hz:

- 90-130 volts
- 200-250 volts

INSTALLING A PLUG ON THE MAINS LEAD

The fixture's mains lead may require a grounding-type cord cap that fits your power distribution cable or outlet. Consult a qualified electrician if you have any doubts about proper installation.

Warning! *For protection from dangerous electric shock, the fixture must be grounded (earthed). The AC mains supply shall have overload and ground-fault protection.*

Important! *Verify that the feed cables are undamaged and rated for the current requirements of all connected devices before use.*

Following the cord cap manufacturer's instructions, connect the yellow and green wire to ground (earth), the brown wire to live, and the blue wire to neutral. The table below shows some pin identification schemes.

Wire	Pin	Marking	Screw color
brown	live	"L"	yellow or brass
blue	neutral	"N"	silver
yellow/green	ground		green

MOUNTING

Ego fixtures can be flown using a clamp (available from your Martin dealer), or fastened to a horizontal or vertical surface.

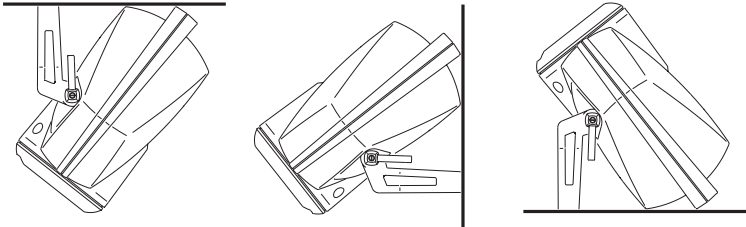

Surface mounting options

Warning! *Block access below the work area before proceeding. Always use a secure means of secondary attachment.*

Do not operate the fixture without fastening it securely to a structure or surface.

Do not install the fixture without the mounting bracket extended, as this reduces the air flow to the fan and may cause overheating.

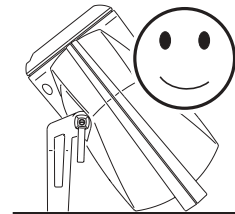

To mount an Ego fixture:

1. Check that the mounting structure or surface can support at least 10 times the weight of all installed fixtures, clamps, cables, auxiliary equipment, and other items.
2. If hanging the fixture with a rigging clamp, check that the clamp is undamaged and is designed for the fixture's weight. Bolt the clamp

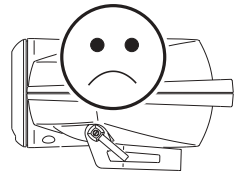

securely to the fixture's mounting bracket with a grade 8.8 (minimum) M12 bolt and lock nut, or as recommended by the clamp manufacturer.

3. If mounting the fixture on a surface, install an eyebolt that can hold ten times the weight of the fixture in the mounting surface for the safety cable.
4. Working from a stable platform, fasten the fixture to the structure or surface. If mounting on a surface, use a grade 8.8 (minimum) M12 bolt or screwbolt, passing it through the hole in the fixture's mounting bracket (see illustration).

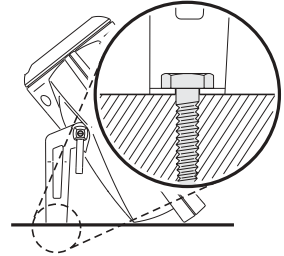

5. Install a safety cable that can hold at least 10 times the weight of the fixture, passing it **through the fixture's handle** (see illustration) and around the mounting structure or through the eyebolt in the mounting surface.

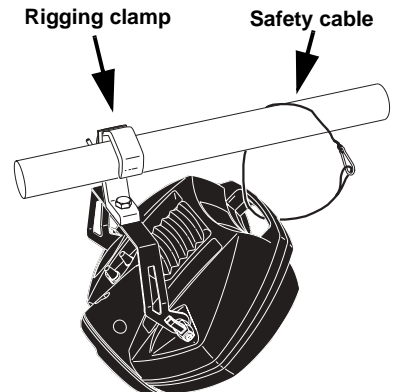

Warning! *Do not simply pass the safety cable through the fixture's mounting bracket, as this will leave the fixture unsecured.*

6. Loosen the swivel locks, tilt the fixture to the desired angle, and retighten.
7. Check that the fixture is held securely.
8. Check that the fixture is at least 0.3 meters (12 in.) from the surface to be illuminated and at least 0.1 meters (4 in.) from any combustible materials.
9. Check that the clearance around the air vents is at least 0.1 meters (4 in.), and that airflow around the vents is free and unobstructed.

LINKING MULTIPLE EGOS FOR SIMULTANEOUS CONTROL

You can link multiple Egos, of any type, using speaker cables with stereo mini-jack connectors for the purpose of controlling them using the optional remote control.

The remote control is connected with a cable to the **Remote In** socket of the first Ego fixture. Additional cables are used from the **Remote Out** sockets to the **Remote In** sockets of subsequent fixtures, and so on, until all the Ego fixtures are connected in a daisy chain. There is no need to terminate this link.

OPERATION

To achieve optimal results the use of smoke effects together with your Ego is recommended.

The lamp turns on as soon as power is applied. The effect wheel/s and mirror dish begin to rotate. The action is varied whenever trigger signals are generated as a result of sounds picked up by the built-in microphone (manual trig) or randomly (when the fixture is in auto trig mode).

SETTING THE TRIG MODE

The Idle Speed dial on the control panel is used to set the trigger mode; when the Idle Speed dial is set:

- In the Auto Trig zone trigger signals are generated randomly in Auto Trig mode. This will result in unsynchronized operation that is not in time with music.
- Out of the Auto Trig zone, the fixture is in Manual Trig mode and the built-in microphone will generate trigger signals as a result of sounds that it picks up. This will result in synchronous operation in time with any music that is being played. When trigger signals are not being received, the effect wheel will idle at a speed that is relative to how far clockwise the Idle Speed dial is set.

ADJUSTING THE EFFECTS

Dynamic

The Dynamic dial on the control panel is used to set the aggressiveness of the effect, regardless of which trig mode is set. When the dial is wound fully anti-clockwise the fixture will react relatively passively, and the level of aggressiveness will increase the further clockwise that the dial is wound.

The separately orderable remote control unit can be used to link multiple Egos and allows the simultaneous adjustment of their dynamics. See “Operation with the optional remote control” on page 13 for more information.

Adjusting the speed of effect wheel

As long as the Idle Speed dial is not in the Auto Trig zone it is used to adjust the speed of rotation of the effects wheel/s between trigger signals.

FOCUSING THE EGO

Adjust the focus using the thumb screw next to the lens.

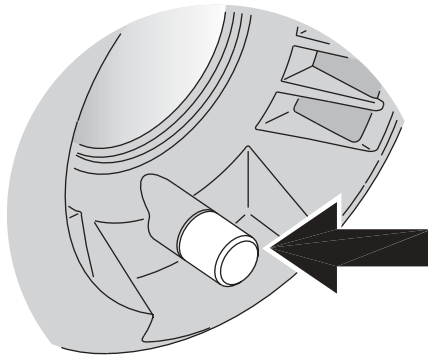

SELECTING THE GOBO ON AN EGO 2

There are two manually-selectable gobos in an Ego 2, one of which is always in the optical path. One is a fixed piece of textured glass and the other interchangeable position is delivered with an etched gobo installed. This gobo can be removed (see “Gobo replacement or removal (Ego 2)” on page 17).

To change the gobo that is currently in the optical path:

- 1 Disconnect the fixture from AC power and allow it to cool. It can take up to 15 minutes for the fixture to cool completely.
- 2 Remove the six access screws from the cover and lift it off. The gobo holder is located between the lamp and the mirror dish.
- 3 Loosen the thumb screw on the gobo holder.

- 4 Pull the tab away from the fixture base to select the textured glass, push it towards the fixture to select the etched gobo position.

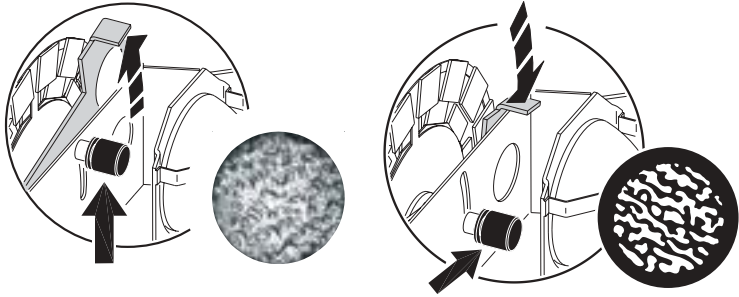

- 5 Tighten the thumb screw.
- 6 Replace the fixture cover and tighten the access screws, taking care not to trap any loose wires.
- 7 Adjust the focus (see “Focusing the Ego” on page 12).

OPERATION WITH THE OPTIONAL REMOTE CONTROL

The (separately orderable) remote control can be used to simultaneously control multiple Ego fixtures that are connected (see “Linking multiple Egos for simultaneous control” on page 10).

A LAMP ON/OFF button is used to turn the fixtures on and off.

A combined dimmer and intensity dial is used to set the intensity of the light and the aggressiveness of the effect, regardless of which trig mode is set. When the dial is set at the beginning of the Dynamic scale, the fixture will react relatively passively, and the level of aggressiveness will increase the further clockwise that the dial is wound.

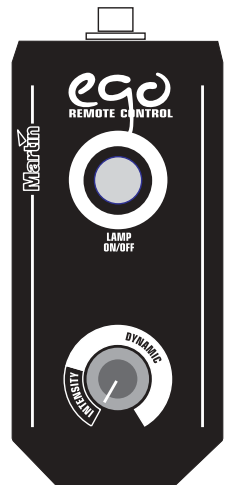

This chapter describes the maintenance procedures that you can perform yourself:

- Cleaning (see below)
- Lamp maintenance (see page 15)
- Replacing fuses (see page 16)
- Gobo replacement/removal (see page 17)
- Updating firmware (see page 17)

CLEANING

Regular cleaning of the elements in the optical path, as well as the fans and air vents, is vital to maintaining the operational quality of the Ego.

Important! Excessive dust, smoke fluid, and particulate buildup degrades performance and causes overheating and damage to the fixture that is not covered by the warranty.

Cleaning the fan and air vents

To maintain adequate cooling, dust must be cleaned from the fan and air vents periodically. Remove dust from the fan and air vents with a soft brush, cotton swab, vacuum, or compressed air.

Cleaning optical components

Clean the optical components regularly. The presence of smudges or dust on optical surfaces can reduce the strength of the light output and the quality of the effects.

Use care when cleaning optical components and work in a clean, well lit area. The coated surfaces are fragile and easily scratched. Do not use solvents that can damage plastic or painted surfaces.

- 1 Disconnect the fixture from power and allow the components to cool completely.
- 2 Remove the fixture cover. You may want to remove the lamp for cleaning (see the related steps in "Installing a lamp in the Ego" on page 15).
- 3 Vacuum or gently blow away dust and loose particles with compressed air.
- 4 Remove stuck particles with an unscented tissue or cotton swab moistened with glass cleaner or distilled water. Do not rub the surface: lift the particles off with a soft repeated press.
- 5 Remove smoke and other residues with cotton swabs or unscented tissues moistened with isopropyl alcohol. A commercial glass cleaner may be used, but residues must be removed with distilled water. Clean with a slow circular motion from center to edge. Dry with a clean, soft and lint-free cloth or compressed air.
- 6 Replace the fixture cover and tighten the access screws, taking care not to trap any loose wires.

LAMP MAINTENANCE

The following lamp types are supported:

- Philips ELC/5H, 24 V / 250 W, 500 hour halogen lamp (included)
- Osram ELC-7/X, 24 V / 250 W, 700 hour halogen lamp
- Philips ELC/8H, 24 V / 250 W, 800 hour halogen lamp
- Osram ELC, 24 V / 250 W, 50 hour halogen lamp

Installing any other lamp may damage the fixture!

Allow the lamp to cool for at least 5 minutes before packing and moving the fixture. To avoid possible damage, remove the lamp when shipping the fixture.

Warning! *Always disconnect the fixture from AC power and allow it to cool for 5 minutes before installing the lamp.*

Installing a lamp in the Ego

- 1 Disconnect the fixture from AC power. If replacing a lamp, allow it to cool for at least 5 minutes before removing the lamp-access cover. The lamp cools faster with the cover in place. It can take up to 15 minutes for the fixture to cool completely.
- 2 Remove the six access screws from the cover and lift it off.

- 3 If replacing a lamp, grasp the old lamp by the reflector and pull it out of the holder. Then pull the socket off the lamp. Do not pull the wires.
- 4 Push the socket fully onto the pins of the new lamp.
- 5 Clean the glass bulb with the cloth supplied with the lamp, particularly if your fingers touched the glass. A clean, lint-free cloth wetted with alcohol may also be used.
- 6 Gently push the lamp into the holder until it snaps into place.
- 7 Replace the fixture cover and tighten the access screws, taking care not to trap any loose wires.

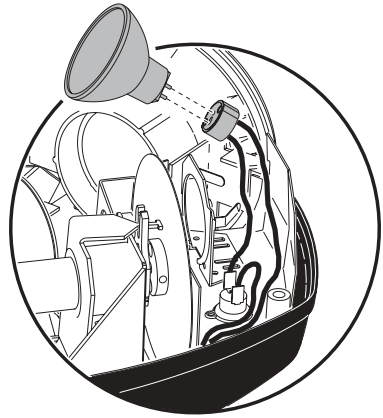

FUSES

The Ego uses a time-delay fuse for protection against current overload. An indication that the fuse may have blown is that when power is applied the lamp does not light and the fan does not operate.

If the fuse blows repeatedly, there is a fault with the unit that requires service by a Martin technician.

Never bypass the fuse or replace it with one of another size or rating.

Replacing the main fuse

- 1 Unplug the mains cable from the input socket.
- 2 Remove the six access screws from the cover and lift it off
- 3 The fuse can be found on the circuit board, a diagram of which can be found on the inside of the fixture cover. Use this to locate the fuse.
- 4 Remove the fuse and replace the fuse with one of the same type. The fuse rating is listed on the serial number label that can be found on the back of the fixture.

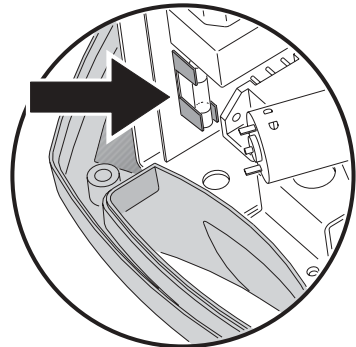

- 5 Replace the fixture cover and tighten the access screws, taking care not to trap any loose wires.

GOBO REPLACEMENT OR REMOVAL (EGO 2)

You can replace (or remove) the etched gobo in an Ego 2 with another aluminium gobo that has:

- An outside diameter of 22.5 mm + 0/- 0.3 mm (0.886 in. +0/- 0.012 in)
- A maximum image diameter of 17 mm (0.669 in)
- A maximum thickness of 1.8 mm (0.071 in)

To replace (or remove) the gobo:

- 1 Unplug the mains cable from the input socket.
- 2 Remove the six access screws from the cover and lift it off. The gobo holder is located between the lamp and the mirror dish.
- 3 Remove the thumb screw on the gobo holder and lift it out to access the interchangeable gobo holder.
- 4 The currently installed gobo can be pressed out of the holder gently with your thumb.
- 5 If you are replacing the gobo, create a gap using a flat head screwdriver, and place the new gobo in the holder.
- 6 Return the gobo holder to its normal position.
- 7 Replace and tighten the thumb screw.
- 8 Replace the fixture cover and tighten the access screws, taking care not to trap any loose wires.

FIRMWARE UPDATES

The factory installed firmware version is indicated on the serial number label.

Firmware is installed using a Martin AVR Uploader and a PC. To install the firmware update, prepare the AVR Uploader as described in its user manual, connect the uploader to the AVR Upload socket on the control panel, and apply power to the fixture. See the AVR user manual for more information.

TROUBLESHOOTING

6

problem	probable cause(s)	suggested remedy
No light	No power to the fixture	Check connections
	Blown fuse	If fan does not function either then check and replace fuse if necessary.
	Burned out lamp	Install new lamp
	Fixture too hot	Allow to cool Improve air flow around fixture
No action	Sound too low to activate control circuit	Increase volume Move speakers closer
	Electrical malfunction	Refer to service technician
Fuse blows repeatedly	Electrical malfunction	Refer to service technician



SPECIFICATIONS

PHYSICAL

Size without standard bracket (L x W x H) 305 x 324 x 150 mm (12 x 12.8 x 5.9 in)
Weight..... 3.8 kg (8.4 lb)

CONSTRUCTION

Housing..... composite plastic
Finish black

THERMAL

Maximum ambient temperature (T_a)..... 40° C (104° F)

INSTALLATION

Minimum distance to combustible materials..... 0.1 m (4 in)
Minimum distance to illuminated surfaces 0.3 m (12 in)
Minimum clearance around fan and air vents..... 0.1 m (4 in)

CONTROL AND PROGRAMMING

Stand-alone triggers music or auto

ELECTRICAL

Input 3-prong IEC male socket
AC Power auto-ranging 90-130 V / 200-250 V, 50-60 Hz
Power and current consumption (@ 230 V, 50 Hz)..... 240 W, 1 A
Power and current consumption (@ 110 V, 60 Hz)..... 250 W 2.2 A
Main fuse 3.15 A T (time delay), P/N 05020013

ACCESSORIES

Ego remote control P/N 91611055
Osram ELC-7/X, 24 V / 250 W, 700 hour halogen lamp P/N 97000108
Philips ELC/5H, 24 V / 250 W, 500 hour halogen lamp P/N 97000107
Osram ELC, 24 V / 250 W, 50 hour halogen lamp P/N 97000104
Half-coupler clamp P/N 91602005