

Destroyer X250

Punisher X250

user manual

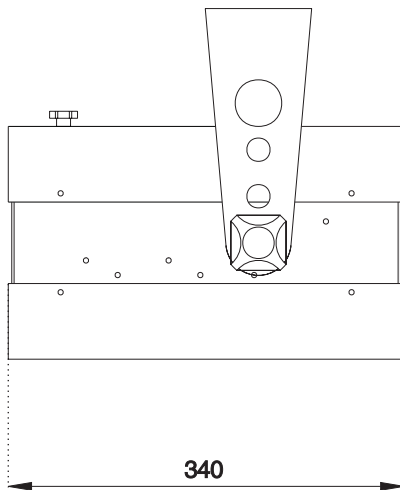

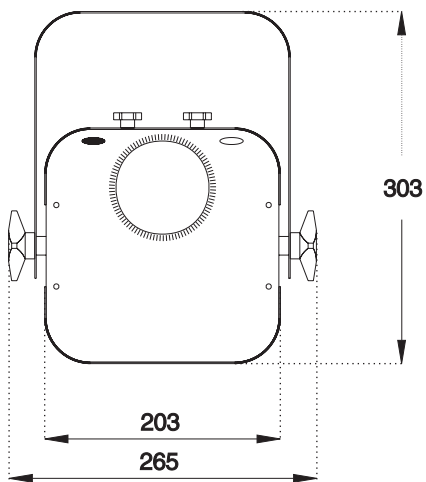

dimensions in millimeters

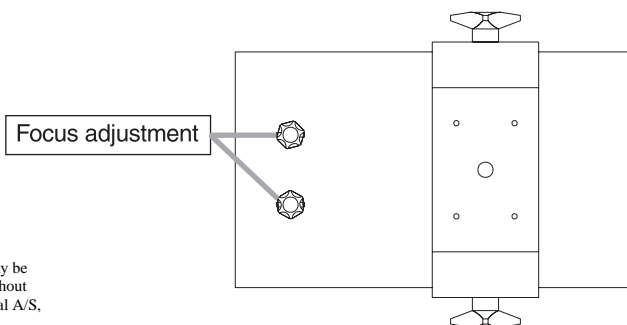
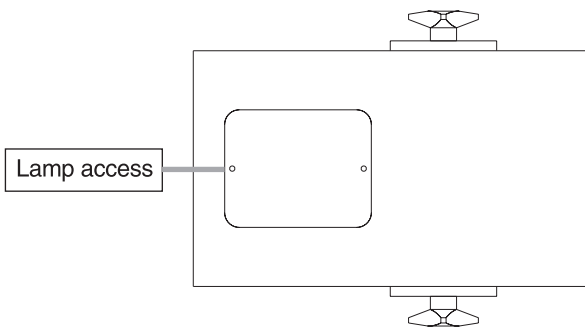

© 1996 - 2001

Martin Professional A/S, Denmark.

All rights reserved. No part of this manual may be reproduced, in any form or by any means, without permission in writing from Martin Professional A/S, Denmark.

Printed in Denmark.

P/N 35000035, Rev. C.

INTRODUCTION

The *Destroyer X250* and *Punisher X250*, developed and manufactured by *Martin Professional*, are aggressive disco lighting effects using a powerful 250W halogen lamp. With a motorized parabolic reflector and gobo wheel, they produce a myriad of turning beams that change color and pattern on demand. There is a “flash” effect for strobe-like animation and, on the *Punisher*, a motor driven “shake” effect.

Unlike most fixtures of this type, the effects of the *Destroyer* and *Punisher* are programmable from any standard DMX-512 controller, using a single or multi-channel protocol. Alternatively, the *Destroyer* and *Punisher* can be directly triggered from a music source as stand-alone units. In addition, the *Destroyer* can run several units in master/client configuration.

FEATURES

- Multiple rotating beams
- 12 pattern gobo wheel, 7 with color and 5 white
- 24 V/250 W halogen lamp
- Dichroic colors
- Adjustable focus
- Sound-activated beam rotation and color/pattern change
- Sound-activated shake effect (*Punisher* only)
- Built-in microphone with automatic sensitivity adjustment
- Multi or single channel DMX control
- Master/client configuration (*Destroyer* only)
- Stepmotor drive
- Adjustable mounting bracket

SAFETY INFORMATION

2

Warning! *This product is not for household use. It presents risks of lethal or severe injury due to fire and heat, electric shock, and falls.*

Read this manual before powering or installing the fixture, follow the safety precautions listed below and observe all warnings in this manual and printed on the fixture. If you have questions about how to operate the fixture safely, please contact a Martin distributor for assistance.

To protect yourself and others from electric shock

- Disconnect the fixture from AC power before removing or installing the lamp, fuses, or any part, and when not in use.
- Always ground (earth) the fixture electrically.
- Use only a source of AC power that complies with local building and electrical codes and has both overload and ground-fault protection.
- Do not expose the fixture to rain or moisture.
- Refer all service to a qualified technician.
- Never operate the fixture with missing or damaged lenses and/or covers.

To protect yourself and others from burns and fire

- Never attempt to bypass the thermostatic switch or fuses. Always replace defective fuses with ones of the specified type and rating.
- Keep all combustible materials at least 0.1 meters (4 inches) away from the fixture. Keep flammable materials well away from the fixture.
- Do not illuminate surfaces within 0.3 meters (12 inches) of the fixture.
- Provide a minimum clearance of 0.1 meters (4 inches) around fans and air vents.
- Replace the lamp if it becomes defective or worn out. When replacing the lamp, allow the fixture to cool for at least 15 minutes before opening the fixture or removing the lamp. Protect your hands and eyes with gloves and safety glasses.
- Never place filters or other materials over the lens.
- The thumbscrews holding the lamp socket assembly reach temperatures up to 120° C (250° F). Allow the fixture to cool for 15 minutes before handling.
- Do not operate the fixture if the ambient temperature (Ta) exceeds 40° C (104° F).

To protect yourself and others from injury due to falls

- When suspending the fixture above ground level, verify that the structure can hold at least 10 times the weight of all installed devices.
- Verify that all external covers and rigging hardware are securely fastened and use an approved means of secondary attachment such as a safety cable.
- Block access below the work area whenever installing or removing the fixture.

The package includes the following items:

Destroyer or Punisher
IEC mains cable
Mounting bracket and hardware
User manual

Before starting to operate the unit you need to:

Install the halogen lamp (not included)
Fit a mains plug
Check voltage setting
Fit the mounting bracket
Rig the unit in its permanent site

WARNING! *Always disconnect the unit from AC power before performing any installation or service procedure.*

INSTALLING THE LAMP

See the specifications on page 16 for lamps that may be used in the Destroyer X250 and Punisher X250. Do not install any other lamp.

Warning! *Allow the unit to cool for 15 minutes before handling.*

- 1 Remove the 2 screws from the lamp access plate on the bottom of the unit.
- 2 Loosen the thumbscrew and pull back on the lamp socket/reflector assembly until the assembly is free of its mounting plate. Remove the lamp assembly.
- 3 Hold the new lamp in a cloth to avoid contaminating it with oils from your fingers. Press it squarely into the socket.
- 4 Hold the lamp assembly by the socket end, with the thumbscrew up. Slide the thumbscrew into the notch on the mounting plate. Align the holes in the assembly with the guide screws on the mounting plate and press the lamp assembly flush against the mounting plate. Tighten the thumbscrew.
- 5 Replace the lamp access cover.

FITTING THE MAINS PLUG

The *Destroyer/Punisher* is delivered from the factory without a plug on the mains cable. You will have to fit a plug that conforms to your local mains outlet. The double insulated mains cable contains three wires.

- 1 Connect the **BROWN** wire to the **LIVE** pin.
- 2 Connect the **BLUE** wire to the **NEUTRAL** pin.
- 3 Connect the **YELLOW/GREEN** wire to the **EARTH** pin.

ADJUSTING THE VOLTAGE SETTING

The voltage setting on the *Destroyer/Punisher* shall match the local power supply. The factory setting is printed on the serial number label on rear of the unit. If the setting does not match the local power supply, rewire the unit as follows:

Important! *To prevent damage, the RED wire must be connected to an outside pin as shown.*

- 1 Disconnect the fixture from AC power. Remove the top cover from the unit by unscrewing the 4 screws that hold it in place.
- 2 Locate and disconnect the plug with red, yellow, and blue wires at the top-right corner of the printed circuit board, as seen from the back of the unit.
- 3 To change to 230 V AC (EU version) or 110 V AC (US version), flip and move the plug *right* so that the *red* wire connects to the pin closest to the edge.
- 4 To change to 245 V AC (EU version) or 120 V AC (US version), flip and move the plug *left* so that the *red* wire connects to the pin furthest from the edge.
- 5 Replace the top cover before applying power.

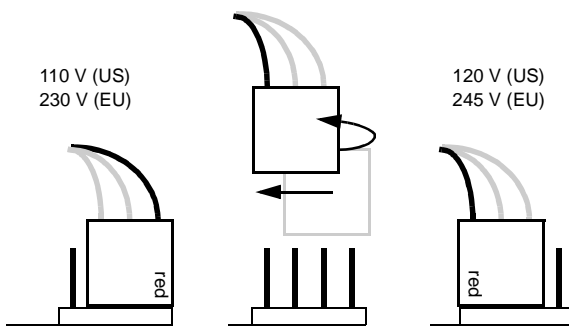

Power setting plug as seen from rear

REMOVING THE TRANSPORT SECURITY PLATE (*PUNISHER* ONLY)

Before first operating the *Punisher*, you need to remove the transport security plate inside the unit. This plate holds the mirror assembly during transit, and must be removed to enable the “shake effect”.

- 1 Remove the top cover from the unit by unscrewing the 4 Phillips screws that hold it in place.
- 2 Locate the parabolic mirror assembly in the center of the unit and unscrew the 4 RED Phillips screws holding the transport plate. Remove the plate.
- 3 Reassemble the unit.

FITTING THE MOUNTING BRACKET

Fit the supplied mounting bracket using the plastic spacers, star washers and thumbscrews. The star washer must be placed between the bracket and the plastic spacer.

RIGGING THE UNIT

- 1 Verify that the structure can support at least 10 times the weight of all installed fixtures, clamps, cables, auxiliary equipment, etc.
- 2 If hanging the fixture with a rigging clamp, verify that the clamp is undamaged and is designed for the fixture’s weight. Bolt the clamp securely to the bracket with a grade 8.8 (minimum) M12 bolt and lock nut, or as recommended by the clamp manufacturer, through the clamp hole in the mounting bracket.
- 3 If permanently installing the fixture, verify that the hardware (not included) and mounting surface can bear at least 10 times the fixture’s weight. The four small holes and the clamp hole in the mounting bracket may be used for attachment.
- 4 Working from a stable platform, clamp or fasten the fixture to the structure.
- 5 Install a safety cable that can hold at least 10 times the weight of the fixture through/over the support and mounting bracket.
- 6 Loosen the thumbscrews, tilt the fixture to the desired angle, and retighten.
- 7 Verify that the fixture is at least 0.3 meters (12 in.) from the surface to be illuminated and at least 0.1 meters (4 in.) from any combustible materials. Verify that the clearance around the air vents is at least 0.1 meters (4 in.).

CONTROLLER OPERATION

CONNECTING THE DATA LINK

A reliable data connection begins with the right cable. Standard microphone cable cannot transmit DMX data reliably over long runs. For best results, use cable specifically designed for RS-485 applications.

The XLR data sockets are wired with pin 1 to ground, pin 2 to signal - (cold), and pin 3 to signal + (hot). This is the standard pin assignment for DMX devices. One or more adaptor cables may be required to connect the fixture to the controller and/or other lights as many devices have 5-pin connectors and others may have reversed signal polarity.

- 1 **Connect a data cable to the controller's output. If controller has a 5-pin output, use a 5-pin male to 3-pin female adaptor cable (P/N 11820005).**
- 2 **Lead the data cable from the controller to the first fixture. Plug the cable into the fixture's data input.**
- 3 **Connect the output of the fixture closest to the controller to the input of the next fixture. If connecting two fixtures with reversed polarity on pins 2 and 3, insert a phase-reversing cable between the two fixtures.**
- 4 **Continue connecting fixtures output to input. Up to 32 devices may be connected on a serial link.**
- 5 **Terminate the link by inserting a male termination plug (P/N 91613017) into the data output of the last fixture. A termination plug is simply an XLR connector with a 120 ohm, 0.25 W resistor soldered across pins 2 and 3.**

5-pin to 3-pin Adaptor		3-pin to 5-pin Adaptor		3-pin to 3-pin Phase-Reversing Adaptor		Male Termination Plug	
Male	Female	Male	Female	Male	Female	Male XLR	
1	1	1	1	1	1	1	
2	2	2	2	2	2	2	
3	3	3	3	3	3	3	
4		4					
5		5					
P/N 11820005		P/N 11820004		P/N 11820006		P/N 91613017	

ADDRESS AND MODE SETTINGS

On the rear of the unit is a 10-way DIP-switch with the following functions:

Switch	ON	OFF
1 - 8	DMX address (1 - 255)	
9	1-channel DMX	Multi-channel DMX (5/6)
10	Client (DMX reception)	Master (DMX transmission - <i>Destroyer</i> only)

DMX MODE SETTING

The *Destroyer/Punisher* has two DMX modes: a 1-channel mode and a multi-channel mode that requires 5 channels for the *Destroyer* and 6 channels for the *Punisher*.

The 1-channel mode is simpler and saves channels on your controller. In this mode, the unit becomes more aggressive the higher you set the fader. The Martin MC-1 controller is specially designed to operate the *Destroyer/Punisher* and other Martin products in 1-channel mode. When using the *Destroyer X250* and *Punisher X250* with the MC-1, the address (see below) must be set to DMX channel 1.

For full control of each effect, use the multi-channel mode. The functions of each mode are described in appendix a.

- **Use DIP-switch 9 to select the DMX mode. Flip the pin ON for 1-channel operation or OFF for multi-channel operation.**

ADDRESS SETTING

Use the first 8 DIP-switches to set the DMX address (the first DMX channel on which the *Destroyer/Punisher* responds to the controller) to any value between 1 and 255. The address is the sum of the values for each individual DIP-switch that is ON.

Important! ***DIP-switch 10 must be flipped ON when using the Destroyer or Punisher with a controller. Otherwise, both the unit and the controller will transmit DMX signals and damage to one or both devices may occur.***

- 1 **Select an address for the fixture on your controller. When using the MC-1 controller, the address must be DMX channel 1.**
- 2 **Look up the DIP-switch setting for the address on page 11.**
- 3 **Set pins 1 through 8 to the ON (1) or OFF (0) position as listed in the table.**
- 4 **Set pin 9 to ON for 1-channel operation, or OFF for multi-channel operation.**
- 5 **Set pin 10 to the ON position.**

ADDRESS TABLE

Locate the channel in the table below. Follow the row to the left to find the settings for pins 1 to 5; follow the column to the top to find the settings for pins 6 to 8. Pin 9 selects DMX mode. Pin 10 selects controller or stand-alone operation and stand-alone master/client on the *Destroyer*.

DIP-Switch Setting 0 = OFF 1 = ON					#10	1: controller, 0: stand-alone													
					#9	1: 1 channel, 0: 5/6 channel DMX													
					#8	0	0	0	0	1	1	1	1						
					#7	0	0	1	1	0	0	1	1						
					#6	0	1	0	1	0	1	0	1						
#1	#2	#3	#4	#5															
0	0	0	0	0															
1	0	0	0	0		1	32	64	96	128	160	192	224						
0	1	0	0	0		2	33	65	97	129	161	193	225						
1	1	0	0	0		3	34	66	98	130	162	194	226						
0	0	1	0	0		4	35	67	99	131	163	195	227						
1	0	1	0	0		5	36	68	100	132	164	196	228						
0	1	1	0	0		6	37	69	101	133	165	197	229						
1	1	1	0	0		7	38	70	102	134	166	198	230						
0	0	0	1	0		8	39	71	103	135	167	199	231						
1	0	0	1	0		9	40	72	104	136	168	200	232						
0	1	0	1	0		10	41	73	105	137	169	201	233						
1	1	0	1	0		11	42	74	106	138	170	202	234						
0	0	1	1	0		12	43	75	107	139	171	203	235						
1	0	1	1	0		13	44	76	108	140	172	204	236						
0	1	1	1	0		14	45	77	109	141	173	205	237						
1	1	1	1	0		15	46	78	110	142	174	206	238						
0	0	0	0	1		16	47	79	111	143	175	207	239						
1	0	0	0	1		17	48	80	112	144	176	208	240						
0	1	0	0	1		18	49	81	113	145	177	209	241						
1	1	0	0	1		19	50	82	114	146	178	210	242						
0	0	1	0	1		20	51	83	115	147	179	211	243						
1	0	1	0	1		21	52	84	116	148	180	212	244						
0	1	1	0	1		22	53	85	117	149	181	213	245						
1	0	1	0	1		23	54	86	118	150	182	214	246						
0	1	1	0	1		24	55	87	119	151	183	215	247						
1	0	0	1	1		25	56	88	120	152	184	216	248						
0	1	0	1	1		26	57	89	121	153	185	217	249						
1	0	1	1	1		27	58	90	122	154	186	218	250						
0	0	1	1	1		28	59	91	123	155	187	219	251						
1	0	1	1	1		29	60	92	124	156	188	220	252						
0	1	1	1	1		30	61	93	125	157	189	221	253						
1	0	1	1	1		31	62	94	126	158	190	222	254						
0	1	1	1	1			63	95	127	159	191	223	255						

STAND-ALONE OPERATION

5

STAND-ALONE

If the unit does not receive control data, it automatically goes into stand-alone mode and performs a random sequence triggered by sounds picked up by the built-in microphone.

STAND-ALONE MASTER/CLIENT (DESTROYER ONLY)

If you have two or more *Destroyers*, this feature allows you to operate all the units in synchronization. *You must assign one, but only one, unit to be master, by setting DIP-switch 10 OFF.* The unit will then be sending DMX signals (via its XLR in and output connectors) that correspond to what it is doing itself. You can then connect up to 32 *clients* which will all perform exactly the same when set to DMX address 1.

Important! *To prevent damage to the electronic circuitry, one, and only one, fixture may be set as master (DIP-switch 10 OFF).*

- 1 Disconnect all fixtures from AC power.
- 2 On the master unit, set DIP-switch 10 OFF.
- 3 On all client units, set DIP-switch 1 and 10 ON.
- 4 Insert a 120Ω female XLR termination plug (P/N 91613018) in the DMX input socket of the master unit.
- 5 Connect the DMX output of the master unit to the input of one of the clients using a XLR-XLR cable. Continue the link this way, always connecting output to input (daisy-chain), until all clients are linked together.
- 6 Finally, insert a 120Ω male XLR termination plug (P/N 91613017) in the free output socket of the last unit on the link.
- 7 Apply power first to the master and then to the client fixtures.

Female Termination Plug
Female XLR
1 2 3 \downarrow 120
P/N 91613018

DMX PROTOCOL



MULTI-CHANNEL MODE

DMX Channel	DMX Value	Description
1	0 - 11	Lamp ON/OFF
	12 - 193	Lamp OFF
	194 - 255	Lamp ON
		Gobo strobe: slow → fast
2	0 - 11	Trigger Mode
	12 - 127	Off
	128 - 255	Music triggered
		Controller triggered - triggers when DMX level crosses 195
3		Parabol Speed
		The rotation time is equal to the trigger decay if trigger mode is set to music or controller.
	0 - 91	Rotation CW, fast → slow
	92 - 98	Stop
	99 - 189	Rotation CCW, slow → fast
	190 - 231	Random CW/CCW slow (music/controller triggered)
	232 - 255	Random CW/CCW fast (music/controller triggered)
4	0 - 4	Trigger Decay
	5 - 252	0 seconds
		0.2 to 9.9 seconds
	253 - 255	Random (music/controller triggered)

DMX Channel	DMX Value	Description
5	0 - 5	Color/Gobo Wheel
		Blackout
	6 - 20	Position 1
	21 - 36	Position 2
	37 - 52	Position 3
	53 - 68	Position 4
	69 - 84	Position 5
	85 - 100	Position 6
	101 - 116	Position 7
	117 - 132	Position 8
	133 - 148	Position 9
	149 - 164	Position 10
	165 - 180	Position 11
	181 - 196	Position 12
197 - 244	No effect	
245 - 255	Random (music/controller triggered)	
6		Shake (<i>Punisher</i> only)
	0-4	Off
	5-252	Slow → fast
	253-255	Random (music/controller triggered)

SINGLE-CHANNEL MODE

Channel	DMX Value	Effect
1	0 - 50	Blackout
	51 - 101	Slow random action
	102 - 152	Medium random action
	153 - 203	Fast random action
	204 - 255	Random speed and action

TROUBLESHOOTING

B

Problem	Probable cause(s)	Suggested remedy
None of the units respond to the controller.	The controller is disconnected from the DMX link.	Connect controller.
	Use of incorrect cable between the controller and the first unit on the DMX link.	Check pin-out of DMX controller against Destroyer/Punisher and ensure that signal + goes to signal + and signal - goes to signal -.
One or more of the units does not respond to the controller or respond erratically.	Bad DMX link connection.	Check connections/cables in the DMX link and correct accordingly.
	DMX link not terminated with termination plug.	Insert termination plug in the last unit on the DMX link.
	Incorrectly addressing (DIP-switch setting) of the unit.	Ensure that all units are addressed in compliance with the controller configuration.
	Unit not powered on.	Power on unit.
	One or more units are set to master, i.e. DIP-switch 10 OFF.	Set DIP-switch 10 ON.
	One of the units is defective and disturbs the data transmission on the link.	By-pass one unit at a time until normal operation is regained. Do this by unplugging the XLR in and out connectors and then connect them directly together.
No light emission from unit.	No lamp or lamp blown.	Install or replace lamp.
Unit appears to be completely dead (no reset when switching on).	Mains fuse blown.	Replace fuse located in power input socket.
	PCB fuse blown.	Replace PCB fuse.
Lamp is cutting out intermittently.	Room temperature is too high.	Reduce room temperature.
	Fan speed is reduced due to fan covered by dirt and dust.	Clean fan and air vents.
	Incorrect voltage setting.	Check voltage setting. Correct if necessary (230/245V, 110/120V).

SPECIFICATIONS

PHYSICAL

Size (L x W x H)..... 340 x 265 x 303 mm (13.4 x 10.4 x 11.9")
Weight..... 7 kg (15.4 lbs.)

THERMAL

Maximum ambient temperature (T_a) 40° C (104° F)
Maximum surface temperature 120° C (250° F)

CONTROL AND PROGRAMMING

Data pin-out pin 1 shield, pin 2 cold (-), pin 3 hot (+)
Control protocol USITT DMX-512 (1990)
DMX channels, Destroyer 1/5
DMX channels, Punisher 1/6

AC POWER

Max. power and current 270 W, 1.2 A @ 230 V; 270 W, 2.3 A @ 120 V
Input socket..... 3-prong IEC male socket
Input, 230/245 V model 230/245 V, 50-60Hz
Input, 110/120 V model 110/125 V, 50-60Hz
Primary fuse, 230/245 V model 2.5 AT / 250 V, P/N 05020010
Primary fuse, 110/120 V model 5.0 AT / 250 V, P/N 05020018

INSTALLATION

Minimum distance to combustible materials 0.1 m (4 in)
Minimum distance to illuminated surfaces 0.3 m (12 in)
Minimum clearance around fan and air vents..... 0.1 m (4 in)

ACCESSORIES

MC-1 controller, EU 90718000
MC-1 controller, US 90718100
50 hour lamp, halogen, EHJ, 24V/250W 97000105
300 hour lamp, halogen, EVC (M33), 24V/250W 97000103
G-clamp 91602003
Half-coupler 91602005