

REVISION HISTORY			
DATE	REV.	DESCRIPTION	BY

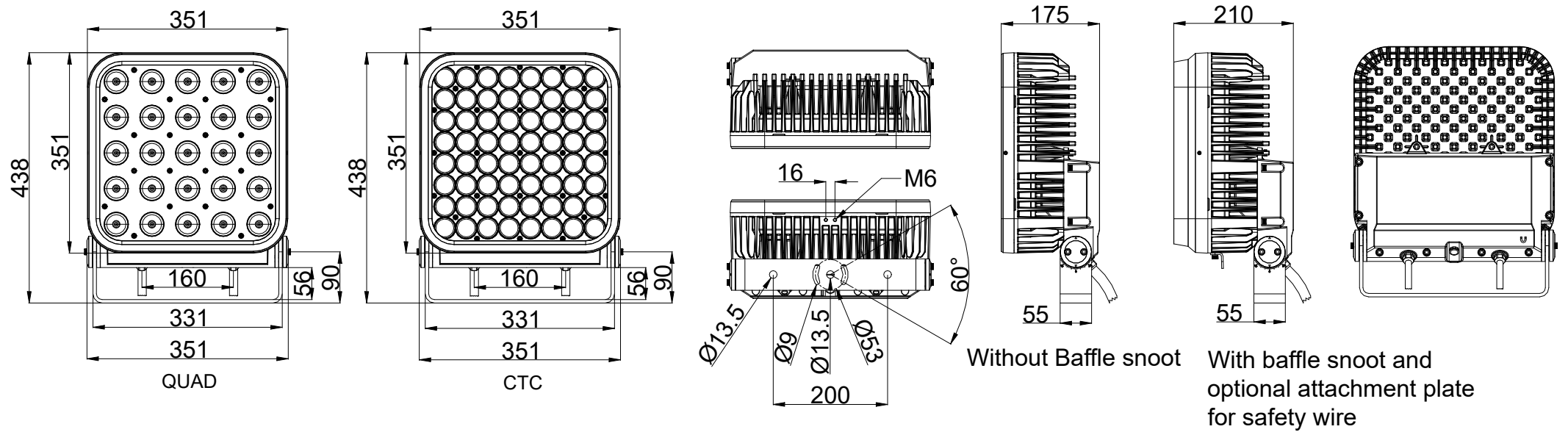

Pre-mounted power and DMX In/Out cables: 2-meter lengths

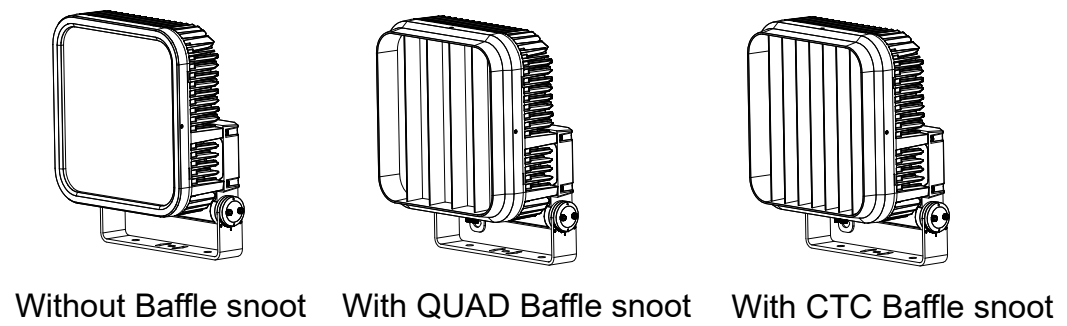

MAR-90590004	EXTERIOR WASH PRO XL QUAD, EU, ALU
MAR-90590008	EXTERIOR WASH PRO XL QUAD, US, ALU
MAR-90590012	EXTERIOR WASH PRO XL CTC, EU, ALU
MAR-90590016	EXTERIOR WASH PRO XL CTC, US, ALU
MAR-90590104	EXTERIOR WASH PRO XL QUAD, EU, WHITE
MAR-90590108	EXTERIOR WASH PRO XL CTC EU WHITE

© 2023 HARMAN Professional Denmark ApS PROPRIETARY AND CONFIDENTIAL PROPERTY OF HARMAN. DO NOT DISCLOSE, REPRODUCE, OR PUBLISH WITHOUT WRITTEN HARMAN APPROVAL.	Material	FIRST ANGLE PROJECTION		HARMAN Professional Denmark ApS Olof Palmes Allé 44 DK 8200 Aarhus N		
	General linear tolerance				Surface treatment	
ROHS RESTRICTION OF HAZARDOUS SUBSTANCES ALL MATERIALS USED IN THIS PART MUST BE ROHS COMPLIANT. SUPPLIER SHALL PROVIDE A CERTIFICATE OF ROHS COMPLIANCE WITH THE FIRST ARTICLE.	General angular tolerance	Color	TITLE (Model in view) EXTERIOR WASH PRO XL			
	General geometrical tolerance	Project number	NO. See above	REV B		
	DIMENSIONS SHOWN ARE FOR REFERENCE AND INSPECTION ONLY. REFER TO CAD MODEL PROVIDED WITH THIS DRAWING FOR OVERALL DEFINITION OF PART GEOMETRY.		SIZE A4	SCALE 1:10	UNIT mm	DO NOT SCALE DRAWING