

# VDO Sceptron XB

## User Manual

with Safety and Installation Manual

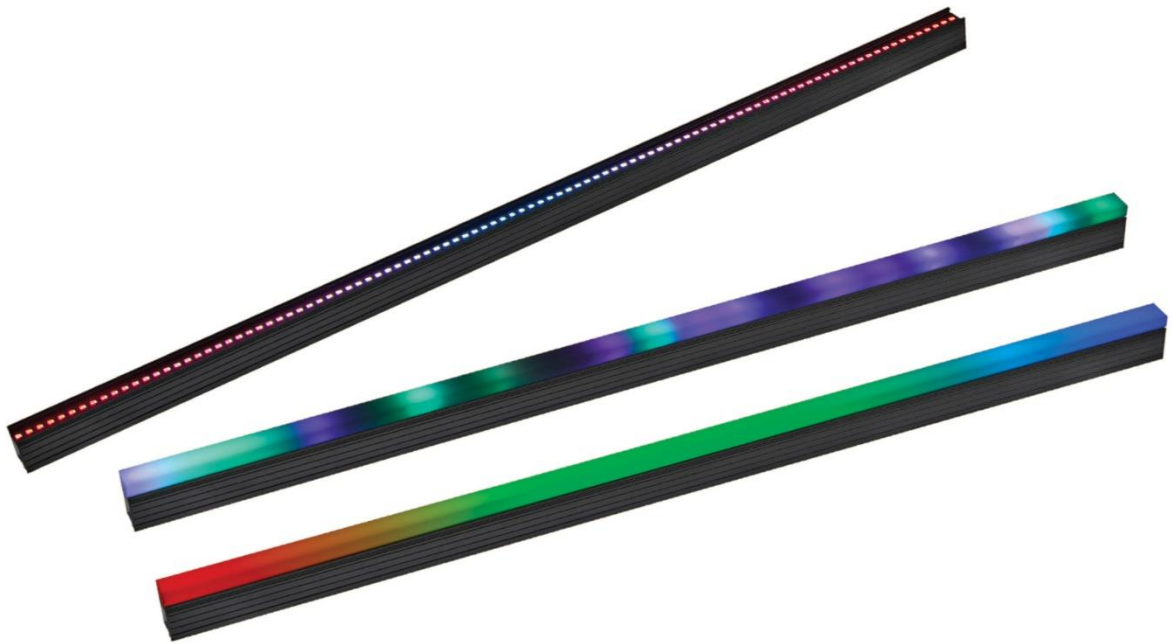

**Martin**<sup>®</sup>

## **Notes**

Revision C of the VDO Sceptron XB user documentation covers firmware version 1.1.0. It gives details of the square law dimming curve that can now be applied to virtual dimmers used on a lighting console. It also sets out limits on the number of fixtures that can be connected in a daisy chain at ambient temperatures below freezing point.

Revision B of the VDO Sceptron XB user documentation gives updated information on use of the magnetic switch on page 27 of the User Manual.

---

©2025-2026 HARMAN PROFESSIONAL DENMARK ApS. All rights reserved. Features, specifications and appearance are subject to change without notice. HARMAN PROFESSIONAL DENMARK ApS and all affiliated companies disclaim liability for any injury, damage, direct or indirect loss, consequential or economic loss or any other loss occasioned by the use of, inability to use or reliance on the information contained in this document. Martin is a registered trademark of HARMAN PROFESSIONAL DENMARK ApS registered in the United States and/or other countries.

HARMAN PROFESSIONAL DENMARK ApS, Olof Palmes Allé 44, 8200 Aarhus N, Denmark  
HARMAN PROFESSIONAL, INC., 8500 Balboa Blvd., Northridge CA 91325, USA

[www.martin.com](http://www.martin.com)

VDO Sceptron XB User Manual and Safety Manual (English) Revision C, P/N 5151761-00

---

# Table of contents

Introduction .....	5
VDO Sceptron XB .....	5
Precautions to avoid damage .....	5
Before using the product for the first time.....	6
System installation .....	7
Creating a chain of VDO Sceptron XB fixtures.....	7
P3 PowerPort and DCE PSU 240 IP devices.....	7
Creating a video-controlled installation.....	8
Creating a DMX-controlled installation .....	9
Creating a mixed control installation.....	10
Using a DCE Data Splitter/Booster IP .....	11
Setting up the VDO Sceptron XB.....	12
Setup methods.....	12
Pixels and segments.....	12
Setting up for DMX control .....	12
Network setup .....	13
Power limit mode .....	13
Dimming curves .....	14
LED refresh rates.....	14
Color modes.....	14
Manual CTC.....	14
Manual Tint value.....	15
Video tracking .....	15
Pixel flip.....	15
Utilities .....	15
Test pattern.....	15
Resetting fixtures .....	15
Disabling DMX reset.....	16
Restoring factory defaults .....	16
Supported parameters .....	16
Fixture information .....	16
Running a self-test.....	16
Status messages .....	17
Hibernation.....	17
RDM communication.....	18
Fixture discovery.....	20
Setting up standalone operation .....	21
Creating a standalone show .....	21
Operating the VDO Sceptron XB .....	26
Test sequences and fixture status.....	26
Identifying fixtures in the installation.....	26
Controlling via Art-Net / sACN .....	26
Combining DMX and P3 control .....	26
Magnetic switch .....	27

DMX protocols.....	28
Compact Mode.....	28
Basic Mode .....	29
Extended Mode.....	31
Compact Direct Mode .....	32
RGB Mode .....	32
PixelMap Mode .....	33
Control / settings channel .....	34
FX overview .....	35
FX list .....	37

# Introduction



**Warning!** Before installing, operating or servicing the VDO Sceptron XB creative LED lighting system, read the latest version of the VDO Sceptron XB Safety and Installation Manual, paying particular attention to the Safety Precautions section. The Safety and Installation Manual is supplied with products and also included at the back of this user manual.

**Important!** Full specifications for VDO Sceptron XB products and accessories are available in the VDO Sceptron XB area of the Martin® website at [www.martin.com](http://www.martin.com).

Thank you for selecting the VDO Sceptron XB from Martin.

This User Guide is a supplement to the Safety and Installation Manual that is supplied with products and attached to the back of this User Manual. This combined User Manual plus Safety and Installation Manual is available for download from the VDO Sceptron XB area of the Martin website. The User Manual contains information that is mainly of interest for lighting designers and operators, whereas the Safety and Installation Manual contains important information for all users, especially installers and technicians.

We recommend that you check the Martin website regularly for updated documentation. We publish revised versions each time we can improve the quality of the information we provide and each time we release new firmware with changes or new features. Each time we revise this guide we list any important changes on page 2 so that you can keep track of updates.

## VDO Sceptron XB

The VDO Sceptron XB from Martin is a powerful, compact and energy-efficient LED batten fixture designed to be used in a creative video installation or as a lighting fixture. Fixtures are available in the following lengths:

- 320 mm fixture with 32 x RGBW pixels, and
- 1000 mm fixture with 100 x RGBW pixels.

The fixture's linear array of LEDs is encapsulated in resin in an aluminum profile to give a rugged IP65-rated fixture that is suitable for permanent and temporary indoor use and temporary outdoor use.

Clip-on optical accessories available from Martin allow the appearance and lighting characteristics of fixtures to be changed in seconds. A hybrid (power and data) cabling system allows VDO Sceptron fixtures to be daisy-chained for easy setup and minimal cabling.

Depending on DMX mode, pixels can be controlled together or separately. Fixtures can be controlled using video mapping via a Martin P3 System Controller or using DMX via any Art-Net or sACN DMX controller. Basic and Extended DMX Modes also let you crossfade between P3 and DMX control of fixtures.

You can use P3 or RDM via Art-Net to set up fixtures, including setting up standalone operation in which fixtures can display up to 20 scenes with individual hold and fade times, with external control not required. Protocol detection is automatic.

## Precautions to avoid damage

**Important!** To get the best out of the VDO Sceptron XB and avoid causing damage that is not covered by the product warranty, read the following information carefully. Make sure that everyone who is involved in working on or using the VDO Sceptron XB has read and understood this information.

Excessive dirt buildup causes overheating and may damage the product. Damage caused by inadequate cleaning is not covered by the product warranty.

### ***Operating temperature precautions***

- Exposing the VDO Sceptron XB to direct sunlight or operating it in an ambient temperature that exceeds the specified maximum of 55° C (131° F) may reduce the lifetime of the product.

- VDO Sceptron XB fixtures have an internal thermal sensor. If the sensor measures excessive temperature, a thermal protection cutout shuts down the fixture. The fixture will not function normally again until the temperature has fallen to a safe level.
- When using a Martin P3 System Controller you can enable "Thermal Throttling" functionality. This feature gradually dims fixtures if they get hot, avoiding full thermal shutdowns.

#### ***Daisy chain limits below freezing point***

- When using the fixture below 0°C in Full-power mode, reduce the number of fixtures per daisy chain by 20%.
- When using the fixture below 0°C in Half-power mode, reduce the number of fixtures per daisy chain by 50%.

### **Before using the product for the first time**

1. Check the support pages on [www.martin.com](http://www.martin.com) for the most recent user documentation and technical information about the product. Martin user manual revisions are identified by the revision letter at the bottom of the inside cover.
2. Read the product's Safety and Installation Manual included at the back of this User Manual before installing, operating or servicing the product.
3. Unpack and ensure that there is no transportation damage before using the product. Do not attempt to operate a damaged product.
4. Install the product as described in the product's Safety and Installation Manual and this User Manual.
5. Remove protective film (if fitted) from optical accessories before applying power.

# System installation



**Warning!** Read “Safety information” and “Precautions to avoid damage” in the VDO Sceptron XB Safety and Installation Manual supplied with products and included at the end of this User Manual before installing a VDO Sceptron XB system.

Connect the VDO Sceptron XB only to the devices and using only the Martin cables specified in this User Manual and the VDO Sceptron XB Safety and Installation Manual.

Do not exceed the maximum numbers of devices that can be connected in chains and maximum cable lengths specified in the VDO Sceptron XB Safety and Installation Manual and in the manuals of the other devices in the system.

Install all devices as described in their Safety and Installation and their User Manuals. All Martin user documentation is available for download from [www.martin.com](http://www.martin.com).

The VDO Sceptron XB is designed to display either Martin P3 video or DMX-controlled lighting effects. It automatically recognizes and responds to either a Martin P3, Art-Net or sACN data signal. When VDO Sceptron XB fixtures are used in a P3-driven setup, you can still control them using an Art-Net or sACN signal that is connected to the P3 System Controller.

See the VDO Sceptron XB area of [www.martin.com](http://www.martin.com) for details of the range of accessories, related devices, pre-assembled cables, bulk cable and connectors available from Martin.

Your Martin supplier will be happy to help you plan your installation and select the most suitable devices and hardware for any given installation.

## Creating a chain of VDO Sceptron XB fixtures

To create a daisy chain of VDO Sceptron XB fixtures:

1. Connect the fixtures together in a chain either directly using the fixtures’ cable tails with DCE connectors or by adding Martin hybrid extension cables with DCE connectors. Do not exceed the maximum total length of fixtures and total chain length given in the VDO Sceptron XB Safety and Installation Manual.
2. Install closing caps on the output connectors of the last fixtures on each chain in order to protect from water, dirt, etc.

## P3 PowerPort and DCE PSU 240 IP devices

Devices in the Martin P3 PowerPort family and the Martin DCE PSU 240 IP let you convert AC mains power to 48 VDC power, combine the DC power with a data signal and send it to VDO Sceptron XB fixtures over hybrid (DC power and data) cable with DCE-type connectors.

Regardless of which model of P3 PowerPort you use or whether you use the DCE PSU 240 IP, you can always choose freely what control protocol you prefer to use. Simply send Art-Net, sACN or Martin P3 into the P3 PowerPort (or DCE PSU) and the system will auto-detect.

## Creating a video-controlled installation

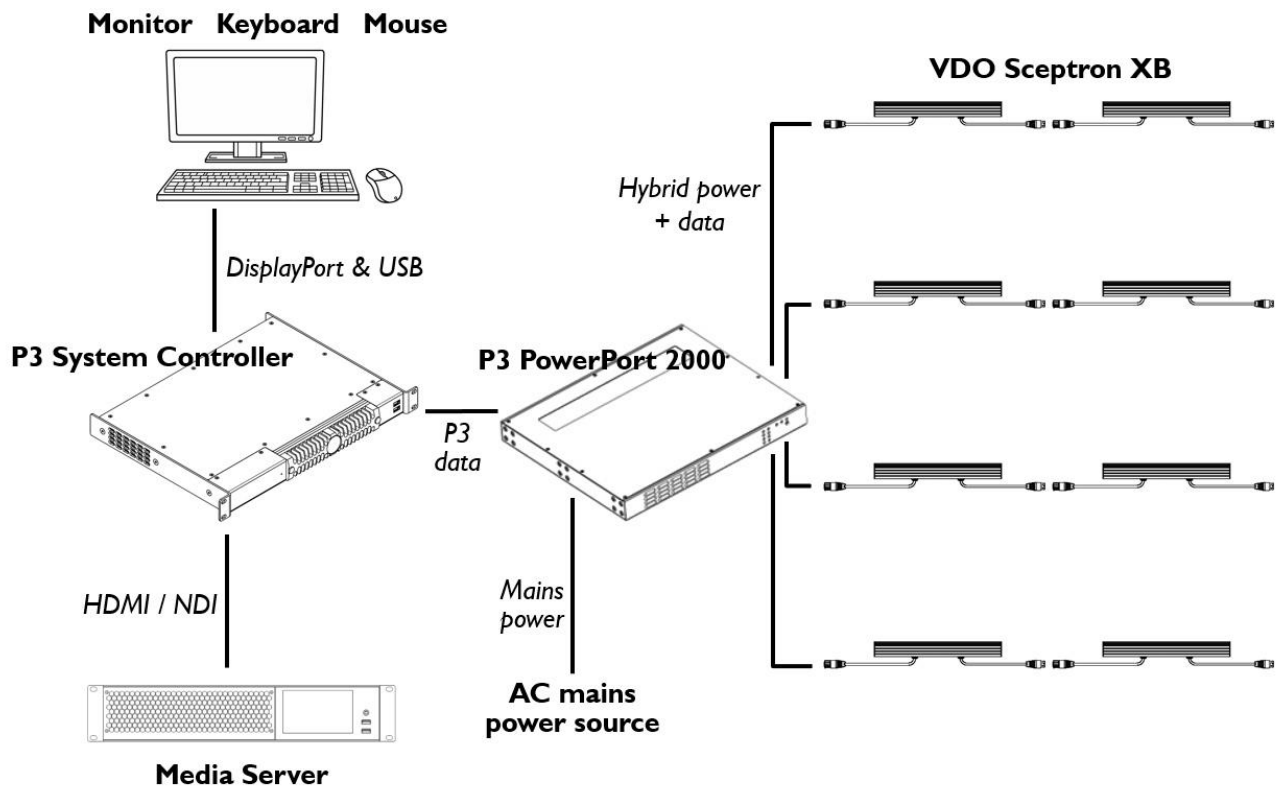

*A P3 PowerPort 2000 is shown here for illustration, but you can also use a P3 PowerPort 500 IP Rental or DCE PSU 240 IP as an alternative*

You can display video on a VDO Sceptron XB installation using a Martin P3 System Controller and a device in the Martin P3 PowerPort family or a Martin DCE PSU 240 IP. Martin P3 controllers simplify pixel mapping, management and setup of the installation with a user-friendly graphic interface.

To set up a P3 video display installation, see the system layout diagram above and follow these instructions:

1. Connect each chain of VDO Sceptron XB fixtures to the hybrid 48 VDC power and data output of a Martin P3 PowerPort device.
2. Supply video to the P3 PowerPort using a P3 System Controller as shown in the system layout diagram.
3. Connect the P3 PowerPort to a source of AC mains power as directed in its user manual and as shown in the system layout diagram.

## Creating a DMX-controlled installation

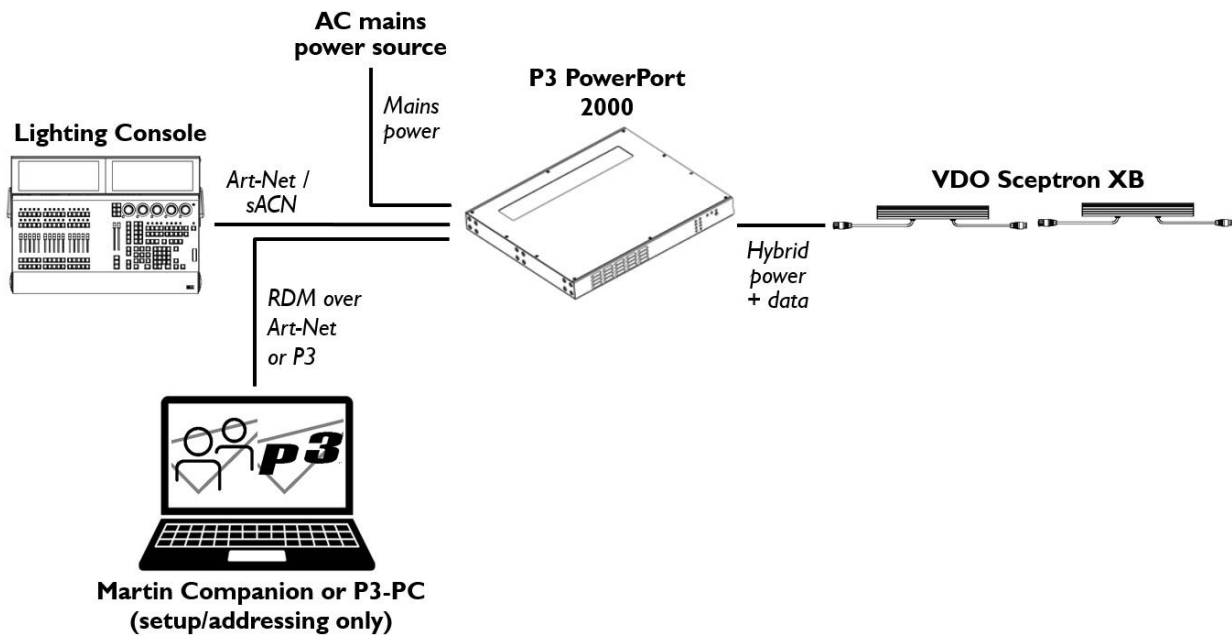

*A P3 PowerPort 2000 is shown here for illustration, but you can also use a P3 PowerPort 500 IP Rental or DCE PSU 240 IP as an alternative*

You can display DMX-controlled lighting effects on a VDO Sceptron XB installation by connecting a DMX lighting controller and a device in the Martin P3 PowerPort family or a Martin DCE PSU 240 IP to add DC power to the Art-Net or sACN signal.

You can use a Windows PC running Martin Companion or Martin P3-PC application to set up the installation, including setting DMX mode and DMX addresses.

To set up a DMX-controlled installation, see the system layout diagram above and follow these instructions:

1. Connect each chain of VDO Sceptron XB fixtures to the hybrid 48 VDC power and data output of a Martin P3 PowerPort or DCE PSU 240 IP.

If you use a DCE PSU 240 IP, you will need to cut the DCE connector off a pre-assembled Martin DCE-to-DCE cable and make DC power and data connections inside the PSU. Instructions for connecting the PSU are provided in the Martin DCE Accessories User Manual that is supplied with PSUs and available for download from [www.martin.com](http://www.martin.com).

P3 PowerPort devices offer advantages over DCE PSU 240 IP devices: P3 PowerPorts let you easily daisy-chain the Art-Net / sACN / Martin P3 signal via their Ethernet THRU port. They also feature a local fixture test button, protocol status indicator, low-power hibernation mode and more.

2. Connect a DMX controller via Ethernet cable to the P3 PowerPort or DCE PSU 240 IP as shown in the system layout diagram.

If you use an RDM-compatible DMX controller, you can carry out nearly all setup functions using RDM over the Art-Net link. You can also connect a PC running the Martin Companion and/or Martin P3-PC Windows applications for additional setup options such as standalone programming and quick DMX addressing.

3. Connect the P3 PowerPort or DCE PSU 240 IP to a source of mains power as directed in its user manual and as shown in the system layout diagram.

## Creating a mixed control installation

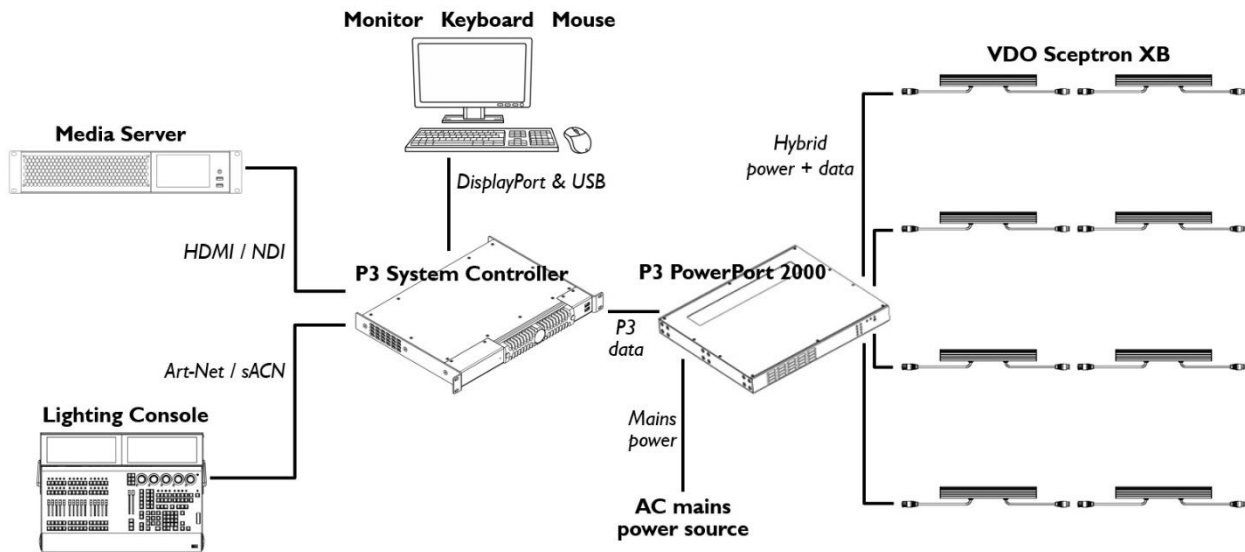

*A P3 PowerPort 2000 is shown here for illustration, but you can also use a P3 PowerPort 500 IP Rental or DCE PSU 240 IP as an alternative*

You can display both video and DMX-controlled lighting effects on a VDO Sceptron XB installation by connecting a DMX lighting controller to a Martin P3 System Controller. The P3 controller lets you manage both video display and DMX lighting effects from the DMX controller.

You can use a device in the Martin P3 PowerPort family or a Martin DCE PSU 240 IP to add 48 VDC power to the data signal.

To set up a combined P3 video and DMX-controlled installation, see the system layout diagram above and follow these instructions:

1. Connect each chain of VDO Sceptron XB fixtures to the hybrid 48 VDC power and data output of a P3 PowerPort or DCE PSU device.
2. Supply video to the P3 PowerPort using a P3 System Controller as shown in the system layout diagram.
3. Connect a DMX lighting controller to the P3 System Controller via Ethernet cable as shown in the system layout diagram.
4. Connect the P3 PowerPort to a source of AC mains power as directed in its user manual and as shown in the system layout diagram.

## Using a DCE Data Splitter/Booster IP

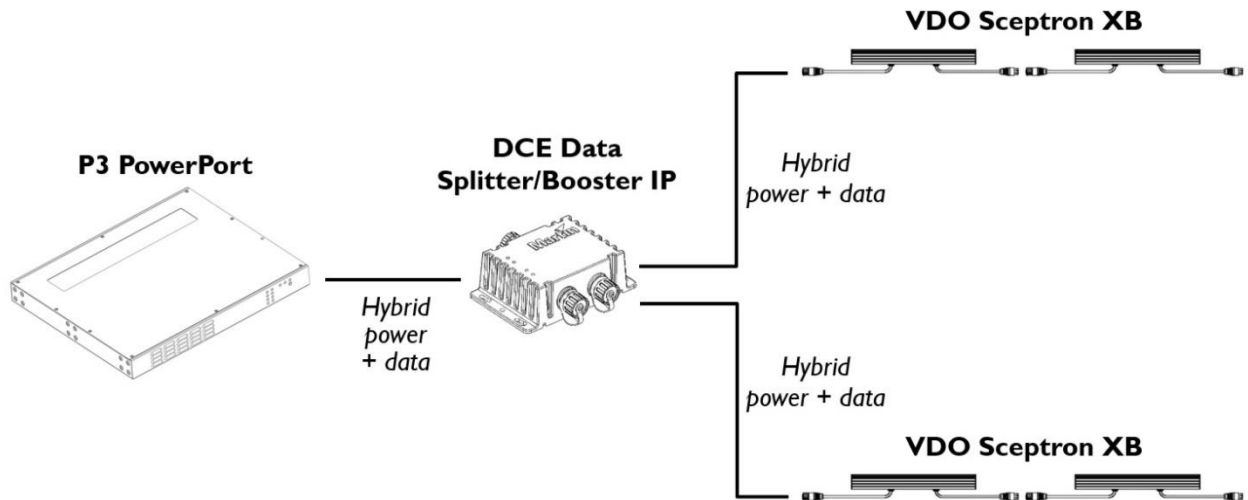

*A P3 PowerPort 2000 is shown here for illustration, but you can also use the Splitter/Booster on a hybrid link coming from a P3 PowerPort 500 IP Rental or DCE PSU 240 IP*

The Martin DCE Data Splitter/Booster lets you extend the distance between a P3 PowerPort or DCE PSU 240 IP and a chain of VDO Sceptron XB fixtures. It also lets you split one hybrid link into two.

**Warning!** The DCE Data Splitter/Booster IP does not enable you to exceed the safety limits for the maximum number of VDO Sceptron XB fixtures per daisy chain (see the VDO Sceptron XB Safety and Installation Manual). It simply allows you to extend the cable length or split the chain into two branches. The maximum number of fixtures per VDO Sceptron XB daisy chain still applies.

To add the Splitter/Booster to an installation, see the system layout diagram above and follow these instructions:

1. Connect each chain of VDO Sceptron XB fixtures to a hybrid output on a DCE Data Splitter/Booster.
2. Connect the hybrid output of either a P3 PowerPort or a DCE PSU 240 IP to the hybrid input of the DCE Data Splitter/Booster.

Refer to the DCE Accessories User Manual supplied with the Splitter/Booster and available for download from [www.martin.com](http://www.martin.com) for details of using the Splitter/Booster's status LEDs to monitor DC power and data on the hybrid link.

# Setting up the VDO Sceptron XB

## Setup methods

You can set up the VDO Sceptron XB using:

- a Martin P3™ System Controller,
- the Martin Companion Windows application running on a PC, and/or
- an RDM-compatible DMX controller.

### Setup using P3

You can set up the VDO Sceptron XB and all the other P3-compatible devices on a P3 data link using a Martin P3 System Controller. See the P3 controller user manual for details of connections and device discovery.

### Setup using Martin Companion

The Martin Companion software suite for Windows can be downloaded free of charge from the Martin website at [www.martin.com](http://www.martin.com). The Martin Companion software suite will always offer the latest VDO Sceptron XB features and firmware when your PC is connected to the Internet.

Martin Companion can communicate with fixtures via RDM over Art-Net.

It offers the following features:

- Simple Windows PC-based user interface
- Update of product firmware
- RDM configuration and addressing
- Standalone show programming with up to twenty scenes and an option to start the show automatically when fixtures are powered on.

### Setup using an RDM-compatible DMX controller

If you are connected to VDO Sceptron XB fixtures via an Art-Net or sACN link, you can set up the fixtures from any RDM-compatible controller that supports RDM over Art-Net. See 'RDM communication' on page 18 for a full overview of RDM functionality.

Note that if you use a P3 System Controller there is no need to use RDM to configure VDO Sceptron XB fixtures because you can carry out all setup, patching and addressing using the P3 System Controller's *DMX & Motion* view.

## Pixels and segments

A pixel is the smallest RGB-controllable unit in a fixture's light output. A segment is a pixel or group of neighboring pixels that can be controlled as a unit.

Pixels and segments are numbered starting from the *female* connector end of fixtures: Pixel 1 and Segment 1 are closest to the female connector end.

## Setting up for DMX control

The VDO Sceptron XB system can be controlled using a DMX-over-Ethernet connection such as Art-Net or sACN.

DMX controllers send control data to devices over DMX control channels in DMX universes. One DMX universe has 512 channels available. Multiple fixtures can share the same DMX channels if you want grouped control and identical fixture behavior.

### Setting DMX addresses

*Available using RDM and P3*

In DMX control, fixtures or segments receive instructions from a DMX controller on their own DMX channels. The DMX address (also known as the control address or start channel) is the first of these channels. A VDO Sceptron XB fixture or pixel uses the DMX address channel and the channels

immediately above it. For example, one VDO Sceptron XB fixture set to RGB Mode and set to DMX address 1 will use DMX channels 1 - 3. Channel 4 will be available for use as a DMX address for the next device.

### **Setting DMX modes**

*Available using RDM and P3*

The VDO Sceptron XB can be controlled using the following DMX modes:

- In **Compact Mode**, each fixture uses 8 x DMX channels.
- In **Basic Mode**, each fixture uses 14 x DMX channels.
- In **Extended Mode**, each fixture uses 14 x DMX channels *plus* between 6 and 300 *additional* DMX channels for individual RGB control of between 2 and 32 segments (320 mm fixtures) or individual RGB control of between 5 and 100 segments (1000 mm fixtures).
- In **Compact Direct Mode**, each fixture uses 8 x DMX channels.
- In **RGB Mode**, each fixture uses 3 x DMX channels.
- In **PixelMap Mode**, each fixture uses between 6 and 300 DMX channels for individual RGB control of between 2 and 32 segments (320 mm fixtures) or individual RGB control of between 5 and 100 segments (1000 mm fixtures).

For details of the control options and commands available in each mode, see 'DMX protocols' starting on page '28'.

Different DMX modes can be mixed in an installation. For example, some VDO Sceptron XB fixtures can be set to Compact Mode and others to Pixelmap Mode. Allocating DMX addresses and DMX channels in a mixed installation will require some planning.

Because DMX mode affects the number of DMX channels a fixture uses, it will affect the assignment of DMX addresses to fixtures. It is therefore a good idea to set the DMX modes of all the fixtures in the installation before you set their DMX addresses.

### **Setting DMX universes**

*Available using RDM and P3*

If an installation needs to use more than the 512 DMX channels available in one DMX universe, you can create additional DMX universes and assign VDO Sceptron XB to those universes using a P3 system controller or Martin Companion.

## **Network setup**

*Available using RDM and P3*

You can set VDO Sceptron XB fixtures to use their default IP address in the 2.x.x.x range (Art-Net standard), or you can manually assign static IP addresses.

IP addressing is not relevant for P3 communication, as P3 traffic is not based on IP addresses.

Fixtures can communicate their Ethernet port information and MAC addresses via RDM.

## **Power limit mode**

*Available using RDM and P3*

You can set fixtures to full- or half-power remotely via RDM or P3.

You can also set fixtures to full or half power by moving a physical switch on Martin P3 PowerPort 500 IP and P3 PowerPort 2000 devices.

Setting fixtures to half power can be useful for night-time or TV studio applications, for example, where full power is not needed or may be undesirable. The HALF setting also lets you connect a higher number of fixtures, meaning that an installation will require fewer system components.

## Dimming curves

Available using RDM, P3 and the Control / settings DMX channel

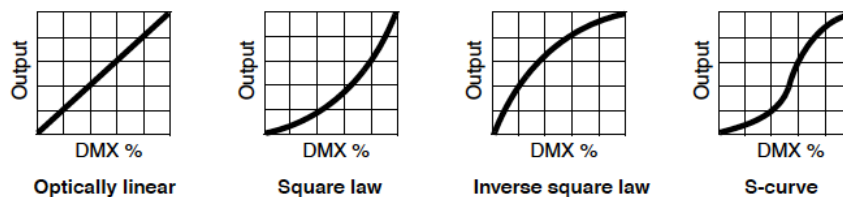

Four dimming curves are available:

- **Optically linear** (default setting) – The increase in light intensity appears to be linear as DMX value is increased.
- **Square law** – light intensity control is finer at low levels and coarser at high levels.
- **Inverse square law** – Light intensity control is coarser at low levels and finer at high levels.
- **S-Curve** – light intensity control is finer at low levels and high levels and coarser at medium levels.

## LED refresh rates

Available using RDM, P3 and the Control / settings DMX channel

You can set the VDO Sceptron XB to one of two PWM refresh rates:

- **Standard** refresh mode (default setting): 1001 Hz
- **High** refresh mode: 4004 Hz.

In High refresh mode, dimming is in 12-bit resolution. In Standard refresh mode, dimming is in 16-bit resolution.

For camera applications, we recommend using High refresh mode.

## Color modes

Available using RDM, P3 and the Control / settings DMX channel

The VDO Sceptron XB has four color modes: Direct, Extended Gamut, Calibrated Color and Linear Video.

When a fixture is set to Compact Direct DMX control mode, it is fixed in Direct Color Mode – you cannot select a calibrated color mode.

When a fixture is set to Compact, Basic, Extended, RGB or Pixelmap DMX control mode, you can select from three color modes via RDM:

- **Extended Gamut** (default setting) – The White point and mixed colors are calibrated, but you can saturate colors to the maximum level available. No brightness calibration is used, so you may observe minor brightness differences between individual fixtures or individual pixels within the same fixture.
- **Calibrated Color** – The entire color gamut is calibrated, resulting in a slight loss of color saturation. Additionally, the brightness of each fixture and each pixel is calibrated for best consistency.
- **Linear Video** – The entire color gamut is calibrated, resulting in a slight loss of color saturation. Additionally, the brightness of each fixture and each pixel is calibrated and adjusted so that the product behaves like a video screen.

## Manual CTC

Available using RDM and P3

You can manually set a default color temperature for fixtures when controlling them in a DMX mode that does not offer CTC.

## Manual Tint value

*Available using RDM and P3*

You can manually set a default tint value for fixtures when controlling them in a DMX mode that does not offer Green/Magenta shift.

## Video tracking

*Available using RDM, P3 and the Control / settings DMX channel*

Video tracking optimizes performance when the VDO Sceptron XB is used with a video source.

With video tracking disabled, the fixture processes the signal it receives, tracking (or smoothing out) changes in values in order to ensure smooth fading between colors and/or intensities. This signal processing takes fractions of a second and is normally invisible, but if the fixture is used to display video this latency can interfere with video response times.

With video tracking enabled (the default setting), the fixture does not 'smooth out' input but instead snaps instantly when a value changes. We recommend that you keep video tracking enabled for most applications.

## Pixel flip

*Available using RDM, P3 and the Control / settings DMX channel*

Pixels are normally numbered starting from the *female* connector end of fixtures. Applying a Pixel flip command reverses the order of the pixels.

This can be useful for setting up symmetrical display in multiple fixtures, for example. Pixel flip also reverses the order of internal FX macros, which lets you easily get FX on different fixtures to move in the same direction, even if fixtures are physically orientated differently.

Note that Pixel flip does not affect P3 pixel mapping. Video pixels are always mapped as they are laid out on the P3 System Controller canvas.

## Utilities

*Available using RDM and P3*

The VDO Sceptron XB offers various functions to help you manage fixtures:

- If you send an IDENTIFY DEVICE command to a fixture, it will flash a signal to let you know which fixture you are communicating with. This can be useful when setting up fixtures in a large installation.
- SELF\_TEST\_DESCRIPTION – Lets you select from various sequences that test the fixture's functionality and LEDs.
- PERFORM\_SELFTEST – Runs a test sequence.
- FACTORY\_DEFAULTS – Deletes any custom settings that have been configured via RDM and returns a fixture to its factory default settings.
- RESET\_DEVICE – Carries out a full reset of the fixture's electronics.

## Test pattern

*Available using P3*

P3 System Controllers let you set fixtures to display a test pattern to ensure correct setup. You can adjust the intensity of the test pattern.

## Resetting fixtures

*Available using RDM, P3 and the Control / settings DMX channel*

It is possible to carry out a complete reset, which restarts the fixture and returns all DMX values (apart from values on the Control / settings DMX channel) that you have sent to the fixture to zero.

## Disabling DMX reset

*Available using RDM and P3*

By default, it is possible to carry out a complete reset on the DMX Control / settings channel by holding a DMX value from 10–14 for 5 seconds. If you send a reset command by mistake, however, you can cause severe disruption to a lighting show. To avoid any possibility of this happening, you can disable the reset command on the DMX Control / settings channel. When this command is disabled, sending the reset value has no function.

## Restoring factory defaults

*Available using RDM and P3*

If at any time you wish to return a fixture to its factory defaults, deleting any custom settings that you have programmed into the fixture, you can send a FACTORY DEFAULTS command via RDM or P3.

This command does not affect factory-set fixture information such as the serial number and RDM ID number, and it does not affect the non-resettable device hours, LED hours and power cycle counters. However, it does zero the user-resettable counters for device hours, LED hours and power cycles.

## Supported parameters

*Available using RDM*

VDO Sceptron XB fixtures can communicate the control parameters that they support to the RDM controller and give brief information on each parameter.

## Fixture information

*Available using RDM and P3*

The VDO Sceptron XB can communicate the following information to the RDM or P3 controller:

- Basic fixture information – type of fixture.
- Name of product and manufacturer.
- Device label – This information can be edited by the user, providing a means of giving an individual fixture its own ID number, for example.
- Unique factory-set RDM ID number.
- Serial number – This is a factory-set fixture serial number.
- Device length (32 or 100 pixels).
- Currently installed firmware version.
- Temperature sensor readouts.

### **Counters**

- Number of hours fixture has had power applied since manufacture.
- Number of hours LEDs have been active since manufacture.
- Number of On/Off power cycles since manufacture.

*Each of the three counters above is implemented as (a) one resettable counter that can be viewed and reset using RDM and P3, and (b) one non-resettable counter that can be viewed using P3 only.*

## Running a self-test

*Available using RDM and P3*

You can set fixtures to run a test sequence that tests all functionality. If the fixture detects an issue, it will create a status message and store it in memory. Status messages can be retrieved via RDM (see below).

## Status messages

*Available using RDM*

The VDO Sceptron XB features a self-diagnostic system that detects any issues concerning correct operation or safety (temperature that exceeds safe level, for example) and communicates the issues as status messages or warnings. These messages can be useful in connection with service and maintenance.

It is possible to:

- Call up a list of any status messages that the fixture has stored in memory.
- View information on the messages.
- Clear the stored list of status messages.

## Hibernation

*Available using RDM, P3 and the Control / settings DMX channel*

You can set fixtures to enter a hibernation state in which normal operation is disabled and power consumption is reduced to a minimum, but you can leave power applied to the installation.

When you take a fixture out of hibernation it performs a reset (just as it does when powered is reapplied after the fixture has been powered off).

# RDM communication

The VDO Sceptron XB responds to the RDM parameter IDs (PIDs) listed in the table below:

RDM DISCOVERY	
0x0001	DISC_UNIQUE_BRANCH
0x0002	DISC_MUTE
0x0003	DISC_UN_MUTE

STATUS INFORMATION		GET	SET	
0x0020	QUEUED_MESSAGE	✓		Get queued messages
0x0030	STATUS_MESSAGES	✓		Get status/error information
0x0031	STATUS_ID_DESCRIPTION	✓		Status/error description
0x0032	CLEAR_STATUS_ID		✓	Clear status/error queue

RDM INFORMATION		GET	SET	
0x0050	SUPPORTED_PARAMETERS	✓		List supported PIDs
0x0051	PARAMETER_DESCRIPTION	✓		Supported PIDs description

PRODUCT INFORMATION		GET	SET	
0x0060	DEVICE_INFO	✓		Get basic info
0x0080	DEVICE_MODEL_DESCRIPTION	✓		Product name
0x0081	MANUFACTURER_LABEL	✓		Manufacturer name
0x0082	DEVICE_LABEL	✓	✓	User- settable label
0x0090	FACTORY_DEFAULTS	✓	✓	Restore factory defaults
0x00C0	SOFTWARE_VERSION_LABEL	✓	✓	Firmware version
0x833C	SERIAL_NUMBER	✓		Factory serial number
0x8700	FIXTURE_LENGTH	✓		Fixture length in pixels

DMX SETUP		GET	SET	
0x00E0	DMX_PERSONALITY	✓	✓	DMX mode
0x00E1	DMX_PERSONALITY_DESCRIPTION	✓		Name of current DMX mode
0x00F0	DMX_START_ADDRESS	✓	✓	DMX address
0x0121	SLOT_DESCRIPTION	✓		DMX channel description

<b>ETHERNET SETUP</b>		<b>GET</b>	<b>SET</b>	
0x0700	LIST_INTERFACES	✓		List Ethernet ports
0x0701	INTERFACE_LABEL	✓		Name of Ethernet port
0x0702	INTERFACE_HARDWARE_ADDRESS_TYPE1	✓		MAC address of Ethernet port
0x0703	IPV4_DHCP_MODE	✓		Enable/Disable DHCP client
0x0705	IPV4_CURRENT_ADDRESS	✓		Get current IP address
0x0706	IPV4_STATIC_ADDRESS	✓	✓	Set static IP address
0x0709	INTERFACE_APPLY_CONFIGURATION		✓	Apply Ethernet configuration

<b>USAGE INFORMATION</b>		<b>GET</b>	<b>SET</b>	
0x0200	SENSOR_DEFINITION	✓		Sensor description
0x0201	SENSOR_VALUE	✓		Sensor readout
0x0400	DEVICE_HOURS	✓	✓	Counter, total number of hours powered on (resettable)
0x0401	LAMP_HOURS	✓	✓	Counter, number of hours LEDs powered on (resettable)
0x0405	DEVICE_POWER_CYCLES	✓	✓	Counter, total number of power cycles (resettable)

<b>CONTROL</b>		<b>GET</b>	<b>SET</b>	
0x1000	IDENTIFY_DEVICE	✓	✓	Highlight device in installation
0x1001	RESET_DEVICE		✓	Warm/Cold Reset
0x1020	PERFORM_SELFTEST	✓	✓	Perform self-test
0x1021	SELF_TEST_DESCRIPTION	✓		Self-test description

<b>STANDALONE</b>		<b>GET</b>	<b>SET</b>	
0x1030	CAPTURE_PRESET		✓	Capture current DMX scene
0x1031	PRESET_PLAYBACK	✓	✓	Play standalone scene
0x8220	MANUAL_MODE_OVERRIDE	✓	✓	Remote manual control
0x810B	PRESET_PLAYBACK_LIMIT	✓	✓	Standalone cue counter
0x8101	SYNCHRONIZED	✓	✓	Sync mode in standalone operation
0x810C	OFFLINE_MODE	✓	✓	Behavior when no DMX signal present

DEVICE SETTINGS		GET	SET	
0x8001	DMX_RESET	✓	✓	Allow fixture to be reset via DMX
0x8003	FIXTURE_ID	✓	✓	User-changeable fixture ID number (also used by P3 controller)
0x8004	COLOR_MODE	✓	✓	Set color mode
0x8310	DIMMER_CURVE	✓	✓	Set dimmer curve
0x8325	VIDEO_TRACKING	✓	✓	Video tracking On/Off
0x8329	HIBERNATION_MODE	✓	✓	Enable/Disable hibernation
0x832F	PIXEL_FLIP_MODE	✓	✓	Reverse pixel numbering end-to-end
0x8330	HIGH_REFRESH	✓	✓	Enable/Disable high PWM frequency mode
0x8335	POWER_LIMIT_MODE	✓	✓	Limit power per fixture
0x8339	MANUAL_CTC_VALUE	✓	✓	Set CTC in DMX Mode that does not have CTC control
0x833A	MANUAL_TINT_VALUE	✓	✓	Set Tint in DMX Mode that does not have Tint control

## Fixture discovery

Before you can communicate with fixtures using RDM, you must send a scan command (fixture discovery command) to all the devices on the data link so that the RDM controller can identify them. It does this by retrieving each device's factory-set unique identifier (UID). This process can take some time, depending on the number of devices on the link.

To identify the fixtures on the link:

1. Check that the fixtures are correctly connected to the RDM controller on the data link and that power is applied to all fixtures.
2. Send a discovery command via RDM (Martin Companion does this automatically as soon as the cable is connected).
3. Give the controller time to identify the devices on the link and prepare for communication with the devices.

# Setting up standalone operation

In standalone mode, the VDO Sceptron XB can display a 'scene' (a color, an intensity or a dynamic FX etc.) or a 'show' that can contain up to twenty scenes if you use Martin Companion. Once standalone scenes have been programmed, fixtures can display them without needing a control signal.

You can program standalone operation using the Martin Companion Windows application that is available for download free of charge from [www.martin.com](http://www.martin.com). Standalone programming using Martin Companion offers the following advantages:

- Standalone show with up to twenty standalone scenes
- Standalone scenes with global or individual fade and hold times
- Easy programming of multiple fixtures simultaneously
- Different types of Martin lighting fixture in one standalone show
- Possibility of automatic standalone show start when fixtures are powered on.

Standalone operation is only possible if no P3 / Art-Net / sACN signal is present. If you connect a P3 / Art-Net / sACN signal to fixtures that are running a standalone show, they will stop standalone operation and respond to that signal.

You must connect the PC running Martin Companion to fixtures via the Art-Net link.

## Creating a standalone show

To program a standalone show using Martin Companion:

1. Connect a PC running the Martin Companion application to the Art-Net link. Apply power to the fixtures on the link that you want to program.
2. Navigate to the Standalone screen within Martin Companion and wait for all fixtures to be discovered automatically. Then select which fixtures you want to program for Standalone operation using the checkboxes in front of them.

You can now:

- click on **Create** to create a new Standalone show for those fixtures,
- or click on **Edit** to modify the Standalone show already present inside the selected fixtures,
- or click on **Clear Fixture(s)** to delete any previous Standalone show from the selected fixtures.

You can also load a previously created show from a file if you click on **Load Show**.

In this example we click on **Create**.

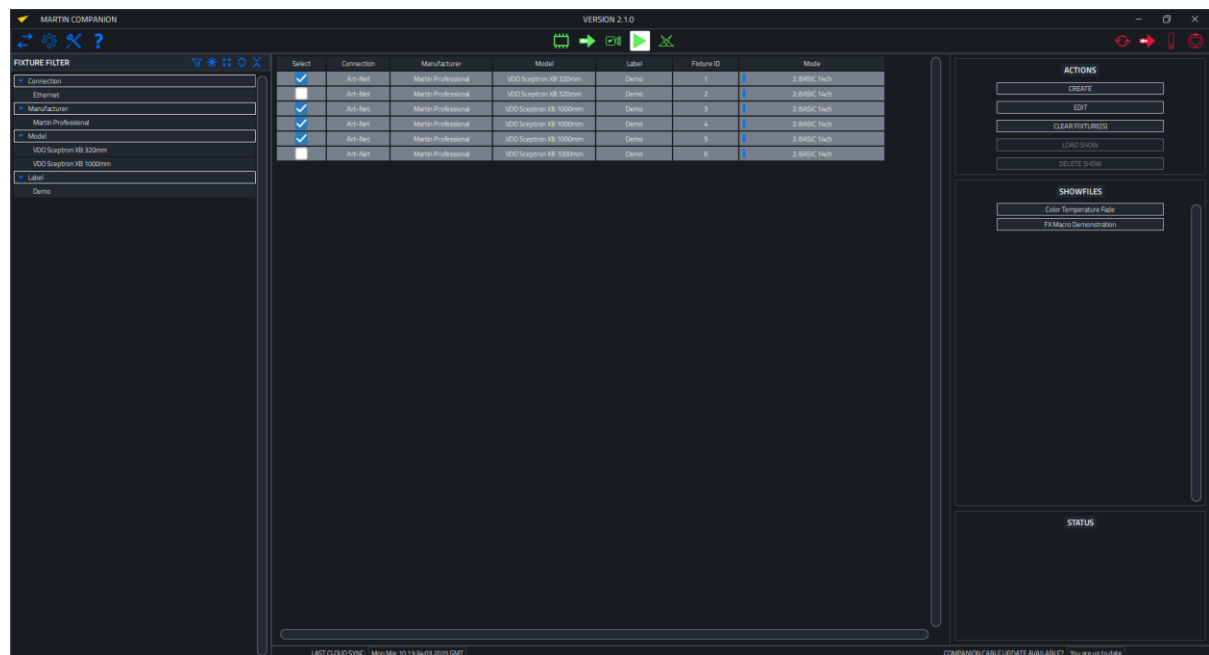

- Now select one or multiple fixtures and create a scene using the faders.

A scene can also contain a dynamic FX macro.

It is possible to create a different scene for each fixture (not all fixtures in a Standalone show have to show the same scenes).

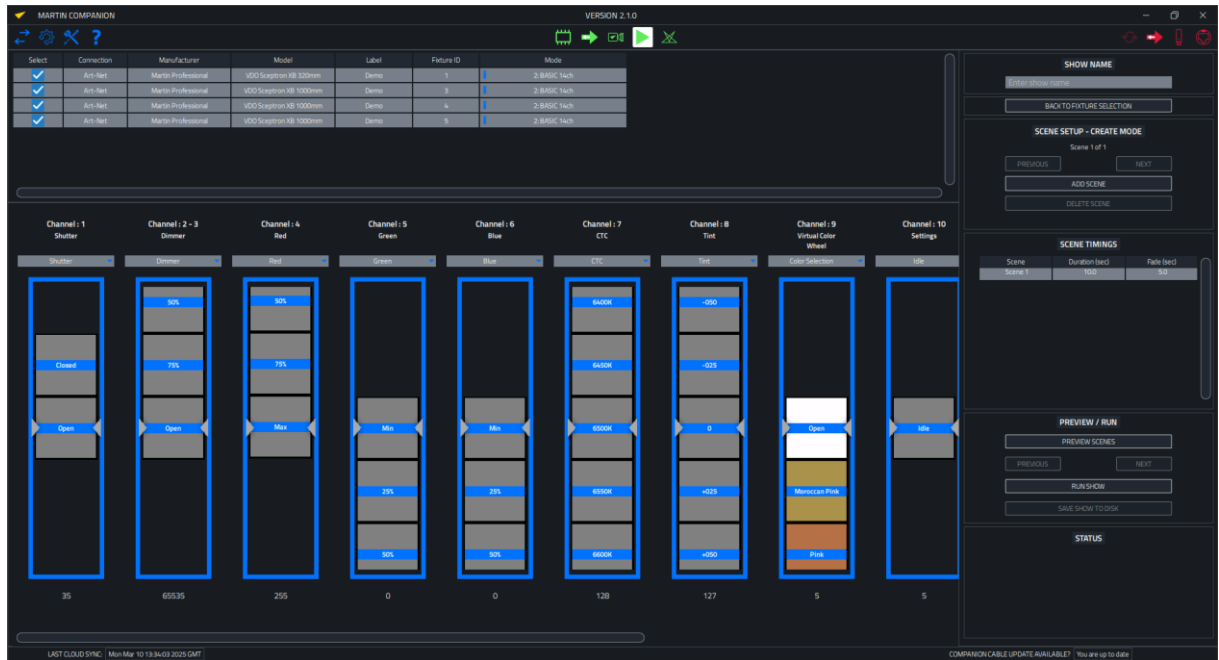

- Click Add Scene to create additional scenes. You can create up to 20 scenes.

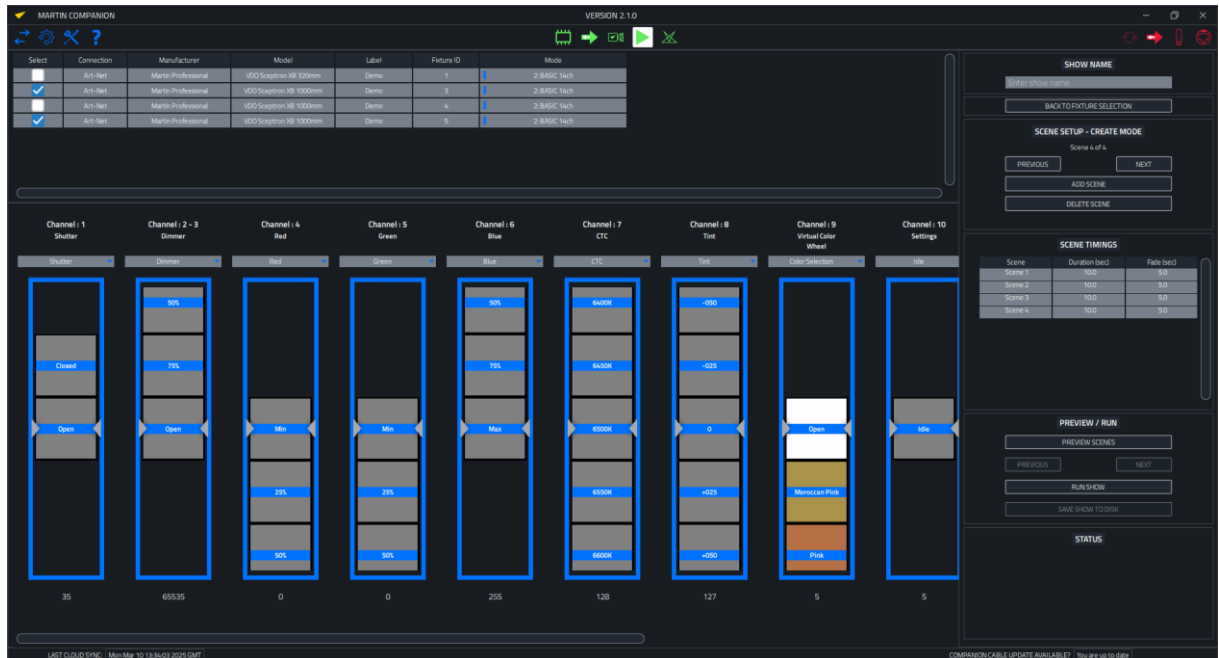

- In the **Scene Timings** field you can enter **Duration** and **Fade** times for each of the scenes.

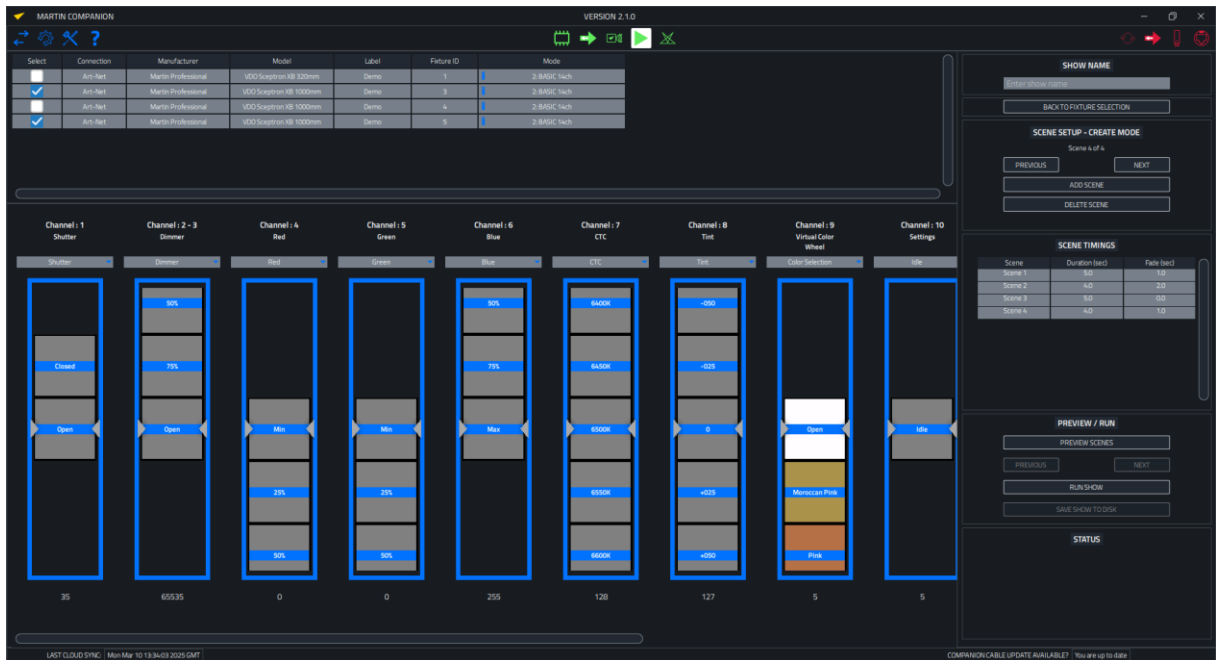

- Click on **Preview Scenes** to see all scenes played back with the timings that have been entered for them. You can click on **Previous** and **Next** to manually step through the scenes. Click **Stop** to end the preview.

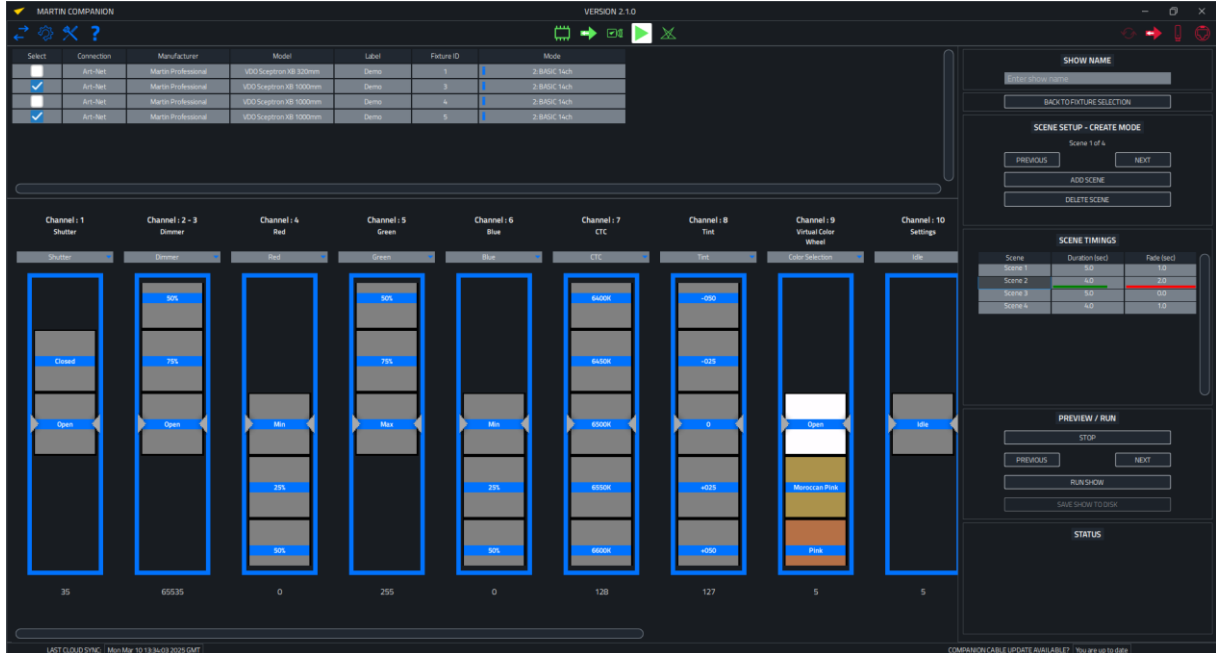

- (Optional) Give a name to your show in the **Show Name** box and click on **Save Show To Disk** to store the Standalone show as a file which can be re-used later.



- Click on **Run Show** to program the Standalone show into the fixtures. Once you disconnect the network cable – the cable between the PC running Martin Companion and the P3 PowerPort(s) – the fixtures will start to run the Standalone show. Martin Companion will automatically elect one fixture to become the Sync Host, which keeps all fixtures synchronized.



### ***Synchronized standalone operation***

All fixtures programmed together for standalone operation will synchronize the playback of their standalone scenes. Fixtures need to be connected to each other using their hybrid power and data cables for synchronization to work, but they do not need to be connected to a P3 / Art-Net / sACN controller. Fixtures that are synchronized will switch to the same scene number with the same duration and fade time, but different fixtures can have a different lighting effect programmed into them for any one scene number.

Note that Martin Companion automatically assigns one fixture as the standalone *host*, and all the others as *clients*. The host fixture only tells the client fixtures to “go to scene X with fade time Y”. The lighting effect that each fixture uses in a specific scene is stored inside each fixture individually. Again, not all fixtures have to show the same lighting effect in each scene. Only the duration and fade times are synchronized.

# Operating the VDO Sceptron XB



**Warning!** Read the Safety and Installation Manual that is included at the end of this User Manual, paying particular attention to the Safety Precautions section, before operating the VDO Sceptron XB.

Note that the output of LEDs, like all light sources, changes gradually over many thousands of hours of use. If you require products to perform to very precise color specifications, you may eventually need to make small readjustments at the lighting controller.

## Test sequences and fixture status

The VDO Sceptron XB Series Safety and Installation Manual that is included at the end of this User Manual contains information on displaying fixture status codes and running test sequences that you may find useful before starting operation.

## Identifying fixtures in the installation

To help with programming scenes and controlling the installation, it is possible to send a command that causes a fixture to flash a signal so that you can identify it. To identify a fixture:

1. Black out all fixtures if you have been using them.
2. If you are using RDM, send an IDENTIFY DEVICE unicast command to an individual fixture in the installation. The fixture will respond by flashing white, letting you identify it.
3. If you are using Martin Companion, enable the “Identify” button in the toolbar. Any fixture (or fixtures) that you select will immediately identify itself. With “Identify” enabled, you can also use the arrow keys to navigate through the list of fixtures – each fixture in the list will flash as soon as you reach it.
4. If you are using P3, select a fixture and click on the **Highlight** button.

## Controlling via Art-Net / sACN

Once you have set up DMX modes and DMX addresses via RDM, you can control fixtures using any standard DMX-512 controller that is connected to the installation. It can be an advantage to use an RDM-compatible DMX controller that you can use for both setup and control.

See the ‘DMX protocols’ section at the end of this manual for full details of the control options and commands available.

## Combining DMX and P3 control

If you connect a DMX controller to a P3 System Controller, you can use both DMX and video control.

Basic and Extended DMX modes feature a P3 Mix channel that lets you crossfade between P3 control only and DMX control only. If you select an intermediate crossfading value, commands sent via DMX color the P3 video.

You can also manually override DMX control at the P3 System controller so that fixtures respond to P3 video only.

If you send P3 *and* Art-Net / sACN signals *at the same time* to fixtures that are not in either Basic or Extended DMX mode, fixtures ignore the P3 video signal and respond only to commands via Art-Net / sACN from the lighting console.

## Magnetic switch

A magnetic sensor is located inside the VDO Sceptron XB behind the **Test/Reset** label on the back of the fixture. The sensor acts as a switch that lets you display the fixture's status, test the LEDs and reset the fixture.

To activate the sensor, swipe a magnet past it. We recommend that you use a Martin Magnetic Test Tool (see photo on right) available from your Martin supplier.



**Martin Magnetic Test Tool**

Swiping or holding a magnet over the sensor has the functions described below.

### **First short swipe**

The first four LEDs and the last LED indicate fixture status by lighting as follows:

LED color	Signal	Status
Blue	Constant	Busy (booting or receiving firmware upload).
Red	Constant	Error. The fixture has detected an error and cannot run.
Red	Flashing	No control source detected (no P3, Art-Net or sACN detected on the Ethernet link).
Green	Flashing	Ready. P3 packets detected, but fixture not in joined state.
Green	Constant	Running normally in P3 mode (P3 joined).
Cyan	Flashing	Ready. Fixture in Art-Net/sACN mode but not receiving valid DMX data.
Cyan	Constant	Running normally in Art-Net/sACN mode.

### **Following short swipes**

Continuing to swipe the magnet past the sensor lets you test the LEDs. Each swipe advances to the next step in the following sequence:

1. All LEDs go to calibrated mixed White at full intensity.
2. All Red LEDs go to full intensity.
3. All Green LEDs go to full intensity.
4. All Blue LEDs go to full intensity.
5. All White LEDs go to full intensity.
6. The fixture exits the test sequence and resumes normal operation.

### **Holding the magnet – rebooting the fixture**

If you hold the magnetic tool over the sensor for a few seconds until the first four LEDs and the last LED light blue, the VDO Sceptron XB resets. The reset takes a few seconds, and the fixture is then ready for normal operation.

### **Returning to normal operation**

Cycling power to the fixture off and on at any point in the test sequence returns the fixture to normal operation.

If the fixture is receiving a control signal via sACN, Art-Net or P3, it will exit the test sequence and return to normal operation approximately 30 seconds after the last magnet swipe, no matter which step it has reached in the sequence.

If the fixture has not been receiving a control signal via sACN, Art-Net or P3 but it begins to receive one, it will exit the test sequence and return to normal operation immediately.

# DMX protocols

The VDO Sceptron XB offers the following DMX control modes:

<b>VDO Sceptron XB 320mm</b>	<b>VDO Sceptron XB 1000mm</b>
<ul style="list-style-type: none"> <li>• Compact Mode</li> <li>• Basic Mode</li> <li>• Extended Mode – 2 Segments</li> <li>• Extended Mode – 4 Segments</li> <li>• Extended Mode – 8 Segments</li> <li>• Extended Mode – 32 Pixels</li> <li>• Compact Direct Mode</li> <li>• RGB Mode</li> <li>• PixelMap Mode – 2 Segments</li> <li>• PixelMap Mode – 4 Segments</li> <li>• PixelMap Mode – 8 Segments</li> <li>• PixelMap Mode – 32 Pixels</li> </ul>	<ul style="list-style-type: none"> <li>• Compact Mode</li> <li>• Basic Mode</li> <li>• Extended Mode – 5 Segments</li> <li>• Extended Mode – 10 Segments</li> <li>• Extended Mode – 25 Segments</li> <li>• Extended Mode – 100 Pixels</li> <li>• Compact Direct Mode</li> <li>• RGB Mode</li> <li>• PixelMap Mode – 5 Segments</li> <li>• PixelMap Mode – 10 Segments</li> <li>• PixelMap Mode – 25 Segments</li> <li>• PixelMap Mode – 100 Pixels</li> </ul>

## Compact Mode

Channel	Resolution	Value	Function	Fade	Default value
1, 2	16-bit	0-65535	<b>Dimmer</b> Closed → Open	Fade	0
3	8-bit	0-255	<b>Red</b> 0 → 100%	Fade	255
4	8-bit	0-255	<b>Green</b> 0 → 100%	Fade	255
5	8-bit	0-255	<b>Blue</b> 0 → 100%	Fade	255
6	8-bit	0-34 35 36 ... 128 ... 255	<b>CTC (Color Temperature Control)</b> <i>1800 K to 12850 K in 50 K steps</i> 1800 K 1850 K 1900 K ... 6500 K ... 12850 K	Fade	128
7	8-bit	0-126 127-128 129-255	<b>Green/Magenta shift (Tint)</b> Shift towards magenta / negative Duv (0 is maximum offset from black body curve = Duv -0.05) No shift (on black body curve) Shift towards green / positive Duv (255 is maximum offset from black body curve = Duv +0.05)	Fade	128
8	<i>Control / settings (see page 34)</i>				

## Basic Mode

Channel	Resolution	Value	Function	Fade	Default value
1	8-bit	0 - 19 20 - 49 50 - 200 201 - 210 211 - 255	<b>Strobe/Shutter</b> Shutter closed Shutter open Strobe (slow → fast) Shutter open Random strobe (slow → fast)	Snap	30
2, 3	16-bit	0-65535	<b>Dimmer</b> Closed → Open	Fade	0
4	8-bit	0-255	<b>Red</b> 0 → 100%	Fade	255
5	8-bit	0-255	<b>Green</b> 0 → 100%	Fade	255
6	8-bit	0-255	<b>Blue</b> 0 → 100%	Fade	255
7	8-bit	0-34 35 36 ... 128 ... 255	<b>CTC (Color Temperature Control)</b> <i>1800 K to 12850 K in 50 K steps</i> 1800 K 1850 K 1900 K ... 6500 K ... 12850 K	Fade	128
8	8-bit	0-126 127-128 129-255	<b>Green/Magenta shift (Tint)</b> Shift towards magenta / negative Duv (0 is maximum offset from black body curve = Duv -0.05) No shift (on black body curve) Shift towards green / positive Duv (255 is maximum offset from black body curve = Duv +0.05)	Fade	128
9	8-bit	0-10 11-12 13-14 15-16 17-18 19-20 21-22 23-24 25-26 27-28 29-30 31-32 33-34 35-36 37-38 39-40	<b>Virtual color wheel</b> Open <b>Solid colors</b> Moroccan Pink (LEE 790) Pink (LEE 157) Special Rose Pink (LEE 332) Follies Pink (LEE 328) Fuchsia Pink (LEE 345) Surprise Pink (LEE 194) Congo Blue (LEE 181) Tokyo Blue (LEE 071) Deep Blue (LEE 120) Just Blue (LEE 079) Medium Blue (LEE 132) Double CT Blue (LEE 200) Slate Blue (LEE 161) Full CT Blue (LEE 201) Half CT Blue (LEE 202)		

9 contd.	8-bit	41-42 Steel Blue (LEE 117) 43-44 Lighter Blue (LEE 353) 45-46 Light Blue (LEE 118) 47-48 Medium Blue Green (LEE 116) 49-50 Dark Green (LEE 124) 51-52 Primary Green (LEE 139) 53-54 Moss Green (LEE 089) 55-56 Fern Green (LEE 122) 57-58 Jas Green (LEE 738) 59-60 Lime Green (LEE 088) 61-62 Spring Yellow (LEE 100) 63-64 Deep Amber (LEE 104) 65-66 Chrome Orange (LEE 179) 67-68 Orange (LEE 105) 69-70 Gold Amber (LEE 021) 71-72 Millennium Gold (LEE 778) 73-74 Deep Golden Amber (LEE 135) 75-76 Flame Red (LEE 164) 77-78 Red Magenta (LEE 113) 79-80 Medium Lavender (LEE 343) 81-82 Pure White (White LEDs only) 83-84 Pure Red (Red LEDs only) 85-86 Pure Yellow (Red + Green LEDs only) 87-88 Pure Green (Green LEDs only) 89-90 Pure Cyan (Green + Blue LEDs only) 91-92 Pure Blue (Blue LEDs only) 93-94 Pure Magenta (Blue + Red LEDs only) 95-96 Peacock Blue (LEE 115) 97-98 Dark Lavender (LEE 180) 99-100 Double CT Orange (LEE 287) 101-102 Full CT Orange (LEE 204) 103-104 Half CT Orange (LEE 205) 105-106 Deep Straw (LEE 015) 107 - 190 <i>No function</i>  <b>Continuous rotation</b> 191 - 214 CW, fast → slow 215 - 219 Stop (wheel stops at current color) 220 - 243 CCW, slow → fast  <b>Random slots</b> 244 - 247 Fast 248 - 251 Medium 252 - 255 Slow	Snap	0
10	<i>Control / settings (see page 34)</i>			
11	8-bit	0 - 26 <b>P3 Mix</b> DMX Mode Color of LEDs is fully controlled by DMX channels, P3 pixel data is ignored 27 - 228 <b>Mix Mode</b> At the bottom of the range (27), the output is pure DMX-controlled. In-between there is a crossfade between DMX and P3 Pixels At the top of the range (228), the output is pure P3 pixel-controlled 229 - 255 <b>Video Mode</b> Color of LEDs is controlled by P3 pixels multiplied with DMX channels. This allows the DMX channels to "color" the P3 pixel data	Snap	0

12	8-bit	0 - 255	<b>FX Select</b> (see 'FX list' on page 37) FX selection 1 -255	Snap	0
13	8-bit	0 - 126 127 - 128 129 - 255	<b>FX Adjust</b> Reversed Fast → Slow Stop Forwards Slow → Fast	Fade	128
14	8-bit	0 1 - 35 36 37 - 100 101 - 120 121 - 140 141 - 255	<b>FX Synchronization</b> No sync fixture offset (Shift from 10–350 degrees) Synchronized <i>No function</i> Random start Random duration <i>No function</i>	Snap	36

## Extended Mode

Channel	Resolution	Value	Function	Fade	Default value
1–14	Identical to Basic Mode				
15–XXX (see below)	8-bit	0–255	<b>RGB control of multiple segments</b> 0 → 100%	Fade	0

Extended DMX Mode is identical to Basic Mode, but it adds direct RGB control of segments with options for individual control of 2, 4, 8 or 32 segments (320 mm fixtures) or of 5, 10, 25 or 100 segments (1000 mm fixtures). You select the number of segments that you want to control individually when you set the fixture's DMX Mode via RDM or P3.

DMX channels are used as follows:

Segment control options	Channels used
<b>320mm variant</b>	
2 x RGB segments with 16 x LEDs each	15–20
4 x RGB segments with 8 x LEDs each	15–26
8 x RGB segments with 4 x LEDs each	15–38
32 x RGB segments with 1 x LED each	15–110
<b>1000mm variant</b>	
5 x RGB segments with 20 x LEDs each	15–29
10 x RGB segments with 10 x LEDs each	15–44
25 x RGB segments with 4 x LEDs each	15–89
100 x RGB segments with 1 x LED each	15–314

Global RGB control on channels 4–6 is added to segment RGB control using HTP (Highest Takes Priority).

## Compact Direct Mode

Channel	Resolution	Value	Function	Fade	Default value
1, 2	16-bit	0-65535	<b>Dimmer</b> Closed → Open	Fade	0
3	8-bit	0-255	<b>Red</b> 0 → 100%	Fade	255
4	8-bit	0 -255	<b>Green</b> 0 → 100%	Fade	255
5	8-bit	0-255	<b>Blue</b> 0 → 100%	Fade	255
6	8-bit	0-255	<b>White</b> 0 → 100%	Fade	255
7	<i>No function</i>				
8	<i>Control / settings (see page 34)</i>				

## RGB Mode

Channel	Resolution	Value	Function	Fade	Default value
1	8-bit	0-255	<b>Red</b> 0 → 100%	Fade	0
2	8-bit	0 -255	<b>Green</b> 0 → 100%	Fade	0
3	8-bit	0-255	<b>Blue</b> 0 → 100%	Fade	0

*CTC defaults to 6500 K but can be changed using RDM.*

*Tint defaults to zero but can be changed using RDM.*

## PixelMap Mode

Channel	Resolution	Value	Function	Fade	Default value
1-XXX (see below)	8-bit	0-255	<b>RGB control of multiple segments</b> 0 → 100%	Fade	0

PixelMap DMX Mode offers direct RGB control of segments, with options for individual control of 2, 4, 8 or 32 segments (320 mm fixtures) or of 5, 10, 25 or 100 segments (1000 mm fixtures). You select the number of segments that you want to control individually when you set the fixture's DMX Mode via RDM or P3.

DMX channels are used as follows:

Segment control options	Channels used
<b>320mm variant</b>	
2 x RGB segments with 16 x LEDs each	1-6
4 x RGB segments with 8 x LEDs each	1-12
8 x RGB segments with 4 x LEDs each	1-24
32 x RGB segments with 1 x LED each	1-96
<b>1000mm variant</b>	
5 x RGB segments with 20 x LEDs each	1-15
10 x RGB segments with 10 x LEDs each	1-30
25 x RGB segments with 4 x LEDs each	1-75
100 x RGB segments with 1 x LED each	1-300

*CTC defaults to 6500 K but can be changed using RDM.*

*Tint defaults to zero but can be changed using RDM.*

## Control / settings channel

The Control / settings DMX channel in each DMX mode has the following functions.

Channel	Resolution	Value	Function	Fade	Default value
<i>Channel depends on DMX mode</i>	8-bit	0 - 9	<i>No function</i>	Snap	0
		10 - 14	Reset fixture (5 sec.)		
		15 - 22	<i>No function</i>		
		23	Linear dimming curve (default, 1 sec.)		
		24	Square law dimming curve (1 sec.)		
		25	Inverse square law dimming curve (1 sec.)		
		26	S-Curve dimming curve (1 sec.)		
		27 - 35	<i>No function</i>		
		36	Video tracking = ON (default, 1 sec.)		
		37	Video tracking = OFF (1 sec.)		
		38	Extended gamut mode (default): calibrated mixed colors, uncalibrated saturated colors, no brightness calibration (1 sec.)		
		39	Calibrated color mode: calibrated mixed and saturated colors, brightness calibration (1 sec.)		
		40	<i>No function</i>		
		41	Linear video mode: calibrated mixed and saturated colors, brightness calibration, intensity of R+G+B = intensity of mixed white (1 sec.)		
		42 - 60	<i>No function</i>		
		61	Hibernation mode = ON (5 sec.)		
		62	Hibernation mode = OFF (default, 5 sec.)		
		63 - 73	<i>No function</i>		
		74	Standalone: record current scene (5 sec.)		
		75	Standalone operation = ON (5 sec.)		
		76	Standalone operation = OFF (default, 5 sec.)		
		77 - 82	<i>No function</i>		
		83	Pixel flip = ON (1 sec.)		
		84	Pixel flip = OFF (default, 1 sec.)		
		85	High refresh = ON, 4004 Hz (1 sec.)		
86	High refresh = OFF, 1001 Hz (default, 1 sec.)				
87 - 255	<i>No function</i>				

The DMX values must be held for the number of seconds indicated in order to activate their function.

# FX overview

The FX (pre-programmed macros) are outlined below:

FX type	Description	Number of effects	Color adjustments	FX adjustment (speed/direction)	FX synchronization (offsetting)
<b>Intensity</b>	<b>Intensity effects on entire fixture</b>	13	<ul style="list-style-type: none"> <li>• RGB or P3 sets foreground color</li> <li>• Virtual color wheel sets background color</li> </ul>	X	X
<b>Pixel intensity</b>	<b>Intensity effects on individual pixels</b>	119	<ul style="list-style-type: none"> <li>• RGB or P3 sets foreground color</li> <li>• Virtual color wheel sets background color</li> </ul>	X	X
<b>Overlay</b>	<b>Overlay effects on individual pixels</b>	26	<ul style="list-style-type: none"> <li>• Overlay color white or set by virtual color wheel</li> <li>• Overlaid on normal output by RGB or P3</li> </ul>	X	X
<b>Color pixel effect</b>	<b>Color effects on individual pixels</b>	44	<ul style="list-style-type: none"> <li>• Predefined color effects</li> <li>• Ignores P3 or DMX colors</li> </ul>	X	X
<b>Color modifier</b>	<b>Color modification on individual pixels</b>	13	<ul style="list-style-type: none"> <li>• Takes DMX or P3 colors and modifies them</li> </ul>	Degree of color offset	X
<b>Video SloMo</b>	<b>Output of LEDs is average of last x frames</b>	1		Number of frames to average	No function
<b>Pixelmasks</b>	<b>256 pixel masks</b>	256	<ul style="list-style-type: none"> <li>• RGB or P3 sets color for "On pixels"</li> <li>• Color wheel sets color for "OFF pixels"</li> </ul>	Selects Pixel mask combination	No function
<b>Color looks</b>	<b>256 predefined color looks</b>	256	<ul style="list-style-type: none"> <li>• Predefined color effects</li> <li>• Ignores P3 or DMX colors</li> </ul>	Selects Color mask combination	No function

<b>Dimming curve effects</b>	Virtual dimmer square law	Enhances bottom end of dimming range when using virtual dimmer on pixel RGB channels	No function
------------------------------	---------------------------	--	-------------

# FX list

The table below lists the FX patterns available in “Extended” DMX mode.

Type	DMX Name
	0 No FX
<b>Intensity all</b>	1 Strobe Width
	2 Blackout Strobe
	3 2x Strobe
	4 3x Strobe
	5 4x Strobe
	6 Up, Down, Flash
	7 Up, Down, Flash Second Color
	8 Up, Flash, Down, Flash
	9 Up, Flash, Down, Flash Second Color
	10 Random Levels
	11 Movie Flicker
	12 Atomic Lighting
	13 Thunderstorm
	14 No FX
	... 18
<b>Pixel intensity</b>	19 Pixel Killer Static
	20 Sparkle Stars
	21 Sparkle Stars Heavy
	22 Lightning Flashes Random
	23 Lightning Flashes Random Heavy
	24 Lightning Flashes Linear
	25 Lightning Flashes Linear Heavy
	26 Fiberoptic
	27 Noise
	28 Build Up/Down Step
	29 Build Up/Down Fade
	30 Build Up/Down Random Step
	31 Build Up/Down Random Fade
	32 Random 5% Step
33 Random 5% Fade	
34 Random 10% Step	
35 Random 10% Fade	

<b>Pixel intensity</b>	36	Random 20% Step
	37	Random 20% Fade
	38	Random 40% Step
	39	Random 40% Fade
	40	Random 80% Step
	41	Random 80% Fade
	42	Split Static
	43	Split Bounce Step
	44	Split Bounce Fade
	45	Odd-Even 1-2 Step
	46	Odd-Even 1-2 Fade
	47	Odd-Even 2-4 Step
	48	Odd-Even 2-4 Fade
	49	Odd-Even 4-8 Step
	50	Odd-Even 4-8 Fade
	51	1-4 Chase Step
	52	1-4 Chase Fade
	53	2-4 Chase Step
	54	2-4 Chase Fade
	55	1-8_10 Chase Step
	56	1-8_10 Chase Fade
	57	1-8_10 Chase Mirror Step
	58	1-8_10 Chase Mirror Fade
	59	4_5-8_10 Chase Step
	60	4_5-8_10 Chase Fade
	61	4_5-8_10 Chase Mirror Step
	62	4_5-8_10 Chase Mirror Fade
	63	1-16_20 Chase Step
	64	1-16_20 Chase Fade
	65	8_10-16_20 Chase Step
	66	8_10-16_20 Chase Fade
	67	4-32_100 Chase Step
	68	4-32_100 Chase Fade
	69	8_10-32_100 Chase Step
70	8_10-32_100 Chase Fade	
71	8_10-32_100 Chase Mirror Step	
72	8_10-32_100 Chase Mirror Fade	
73	Block Chase 2/5 Step	

<b>Pixel intensity</b>	74	Block Chase 2/5 Fade
	75	Block Chase 2/5 Step Random
	76	Block Chase 2/5 Fade Random
	77	Block Chase 4/10 Step
	78	Block Chase 4/10 Fade
	79	Block Chase 4/10 Step Random
	80	Block Chase 4/10 Fade Random
	81	Block Chase 8/25 Step
	82	Block Chase 8/25 Fade
	83	Block Chase 8/25 Step Random
	84	Block Chase 8/25 Fade Random
	85	Snake 1 LED Step
	86	Snake 1 LED Fade
	87	Snake 2 LED Step
	88	Snake 2 LED Fade
	89	Snake 4 LED Step
	90	Snake 4 LED Fade
	91	Snake 8 LED Step
	92	Snake 8 LED Fade
	93	Snake 16 LED Step
	94	Snake 16 LED Fade
	95	Snake 32 LED Step
	96	Snake 32 LED Fade
	97	Snake Bounce 1 LED Step
	98	Snake Bounce 1 LED Fade
	99	Snake Bounce 2 LED Step
	100	Snake Bounce 2 LED Fade
	101	Snake Bounce 4 LED Step
	102	Snake Bounce 4 LED Fade
	103	Snake Bounce 8 LED Step
	104	Snake Bounce 8 LED Fade

<b>Pixel intensity</b>	105	Snake Bounce 16 LED Step	
	106	Snake Bounce 16 LED Fade	
	107	Snake Bounce 32 LED Step	
	108	Snake Bounce 32 LED Fade	
	109	Half Sine	
	110	Double Half Sine	
	111	5/4 Half Sine	
	112	Sine	
	113	Double Sine	
	114	5/4 Sine	
	115	Exp	
	116	Double Exp	
	117	5/4 Exp	
	118	InExp	
	119	Double InExp	
	120	5/4 InExp	
	121	Ramp Up	
	122	Double Ramp Up	
	123	5/4 Ramp Up	
	124	Ramp Down	
	125	Double Ramp Down	
	126	5/4 Ramp Down	
	127	Sawtooth	
	128	Double Sawtooth	
	129	5/4 Sawtooth	
	130	Nightrider	
	131	Starfield	
	132	Starfield Heavy	
	133	Snowflakes	
	134	Snowflakes Heavy	
	135	Rain	
	136	Rain Heavy	
	137	Waterdrop	
		138 ... 143	No FX

<b>Overlays</b>	144	Overlay Sparkle Stars
	145	Overlay Sparkle Stars Heavy
	146	Overlay Lightning Flashes Random
	147	Overlay Lightning Flashes Random Heavy
	148	Overlay Lightning Flashes Left-Right
	149	Overlay Lightning Flashes Top-Bottom
	150	Overlay Fiberoptic
	151	Overlay Noise
	152	Overlay Random 5% Step
	153	Overlay Random 5% Fade
	154	Overlay Random 10% Step
	155	Overlay Random 10% Fade
	156	Overlay Random 20% Step
	157	Overlay Random 20% Fade
	158	Overlay Random 40% Step
	159	Overlay Random 40% Fade
	160	Overlay Random 80% Step
	161	Overlay Random 80% Fade
	162	Overlay Nightrider
	163	Overlay Starfield
	164	Overlay Starfield Heavy
	165	Overlay Snowflakes
	166	Overlay Snowflakes Heavy
	167	Overlay Rain
168	Overlay Rain Heavy	
169	Overlay Waterdrop	
	170	No FX
	...	
	175	
<b>Color pixels</b>	176	Rainbow LEDs Step
	177	Rainbow LEDs Fade
	178	Random Rainbow LEDs Step
	179	Random Rainbow LEDs Fade
	180	Red-Yellow LEDs Step
	181	Red-Yellow LEDs Fade
	182	Random Red-Yellow LEDs Step
	183	Random Red-Yellow LEDs Fade

<b>Color pixels</b>	184	Yellow-Green LEDs Step
	185	Yellow-Green LEDs Fade
	186	Random Yellow-Green LEDs Step
	187	Random Yellow-Green LEDs Fade
	188	Green-Cyan LEDs Step
	189	Green-Cyan LEDs Fade
	190	Random Green-Cyan LEDs Step
	191	Random Green-Cyan LEDs Fade
	192	Cyan-Blue LEDs Step
	193	Cyan-Blue LEDs Fade
	194	Random Cyan-Blue LEDs Step
	195	Random Cyan-Blue LEDs Fade
	196	Blue-Magenta LEDs Step
	197	Blue-Magenta LEDs Fade
	198	Random Blue-Magenta LEDs Step
	199	Random Blue-Magenta LEDs Fade
	200	Magenta-Red LEDs Step
	201	Magenta-Red LEDs Fade
	202	Random Magenta-Red LEDs Step
	203	Random Magenta-Red LEDs Fade
	204	Red White Blue Step
	205	Red White Blue Fade
	206	Fire
	207	Water
	208	Swimming pool
	209	Ice
	210	Hot and cold
	211	Warm and fuzzy
	212	Silver and gold
	213	Gold and silver
214	Electric arc	
215	Plasma	
216	Police Car 1	
217	Police Car 2	
218	Police Car 3	
219	Welding	

<b>Color modifier</b>	226	Spectrum Shifter Static
	227	Spectrum Shifter Step
	228	Spectrum Shifter Fade
	229	Pixel Spectrum Shifter Static
	230	Pixel Spectrum Shifter Step
	231	Pixel Spectrum Shifter Fade
	232	Pixel Spectrum Shifter Random Static
	233	Pixel Spectrum Shifter Random Step
	234	Pixel Spectrum Shifter Random Fade
	235	Color Toggle Step
	236	Color Toggle Fade
	237	Tungsten
	238	Tungsten Delay
	239 ... 243	No FX
	<b>Timing</b>	244
	245 ... 250	No FX
<b>Special</b>	251	Pixel Masks Static
	252 253	No FX
<b>Special</b>	254	Color Looks Static
<b>Dimming curve FX</b>	255	Virtual dimmer square law



# VDO Sceptron XB

## Safety and Installation Manual

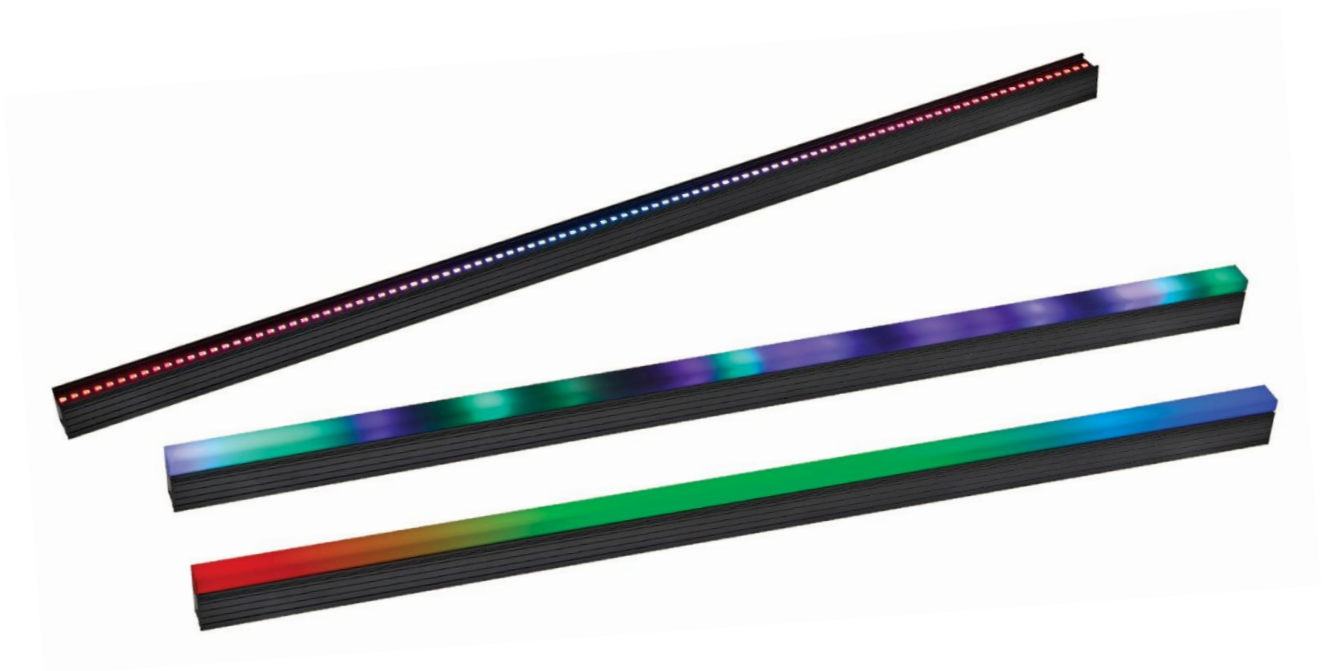

**Martin**<sup>®</sup>

# Dimensions

All dimensions are in millimeters

## VDO Sceptron XB

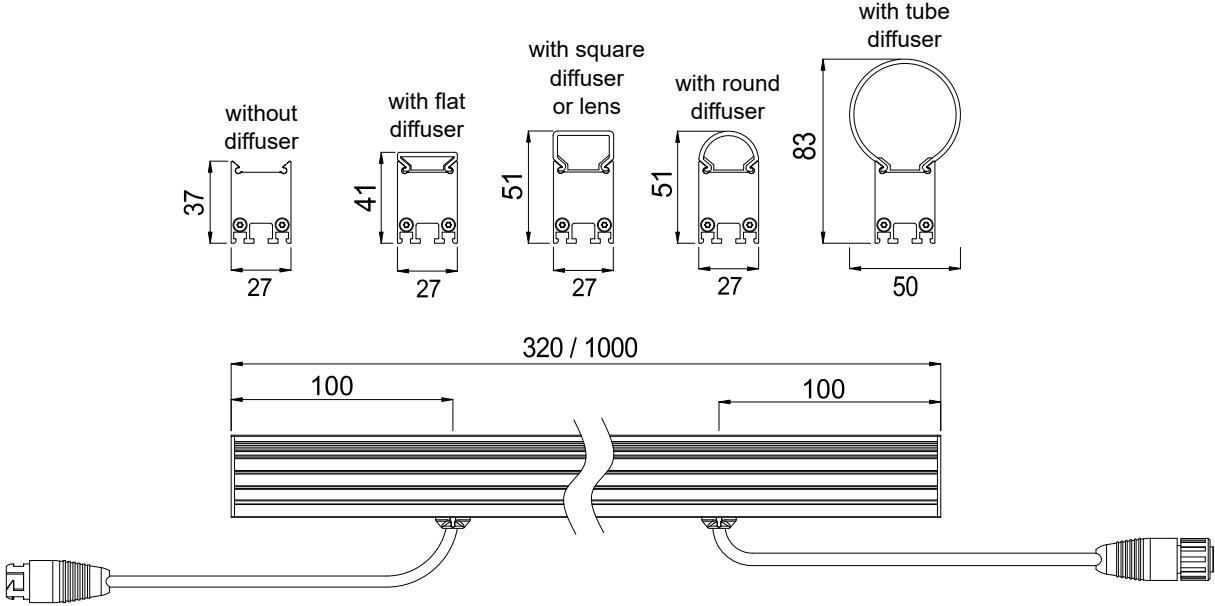

## VDO Sceptron XB Sliding bracket

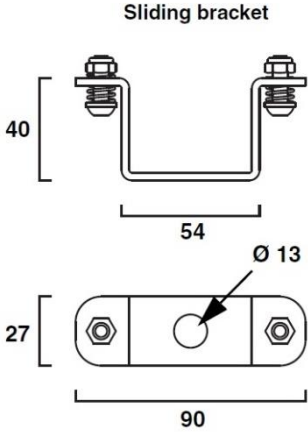

©2024-2026 HARMAN PROFESSIONAL DENMARK ApS. All rights reserved. Features, specifications and appearance are subject to change without notice. HARMAN PROFESSIONAL DENMARK ApS and all affiliated companies disclaim liability for any injury, damage, direct or indirect loss, consequential or economic loss or any other loss occasioned by the use of, inability to use or reliance on the information contained in this document. Martin is a registered trademark of HARMAN PROFESSIONAL DENMARK ApS registered in the United States and/or other countries.

HARMAN PROFESSIONAL DENMARK ApS, Olof Palmes Allé 44, 8200 Aarhus N, Denmark  
HARMAN PROFESSIONAL, INC., 8500 Balboa Blvd., Northridge CA 91325, USA

[www.martin.com](http://www.martin.com)

### VDO Sceptron XB Low Profile Half Coupler

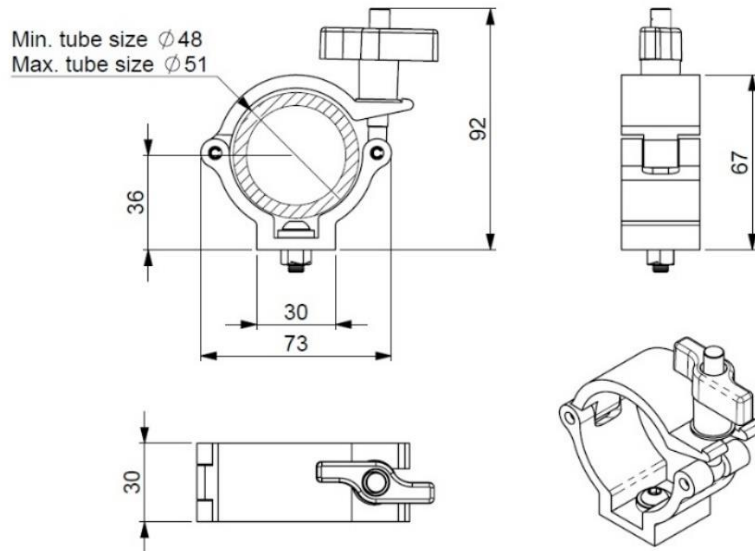

### VDO Sceptron XB Floor Stand Pair

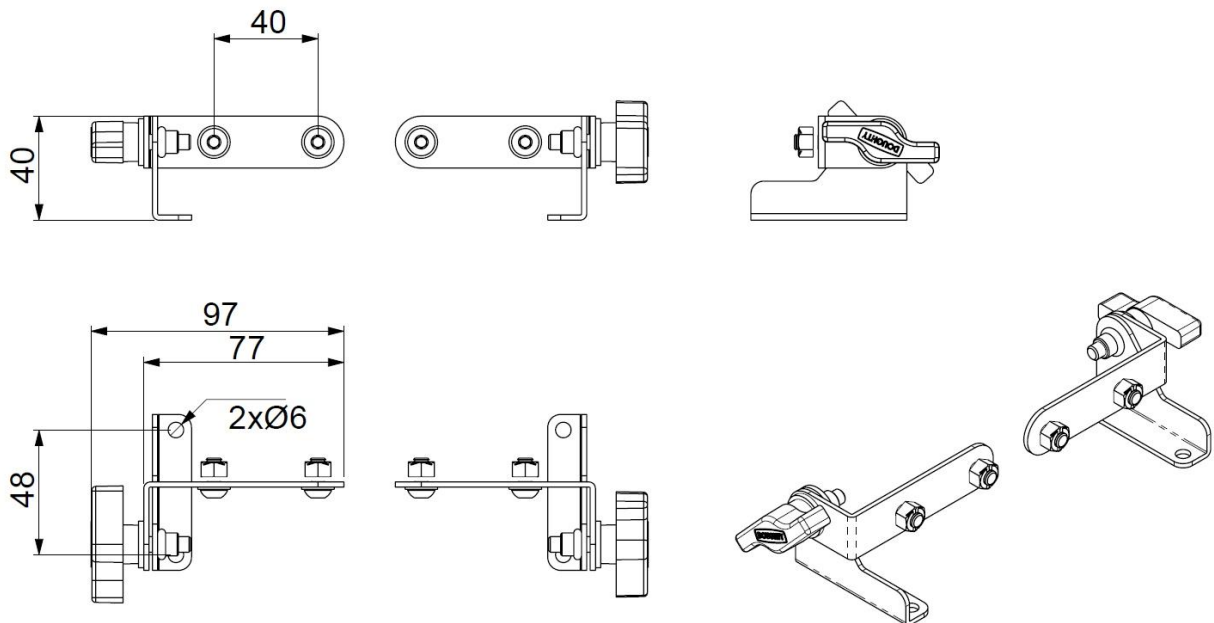

### VDO Sceptron XB Linear Coupler

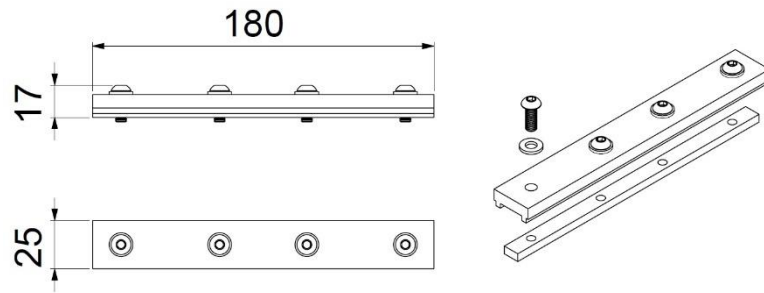

### VDO Sceptron XB Linear Aligner

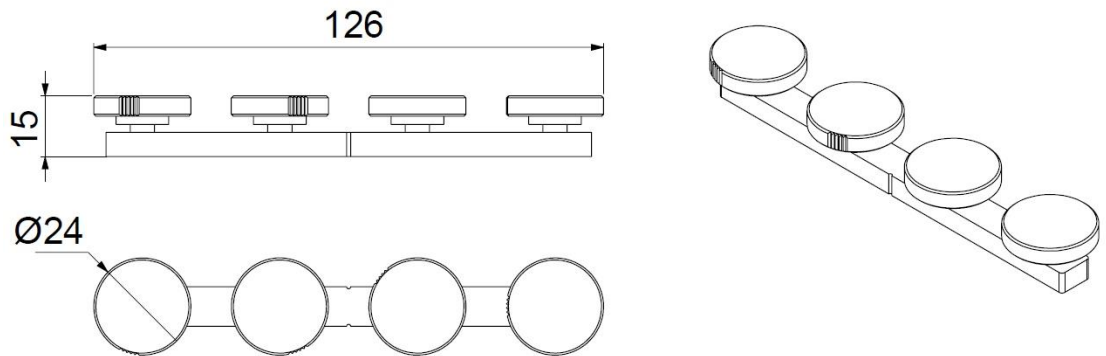

### VDO Sceptron XB Spigot Adapter

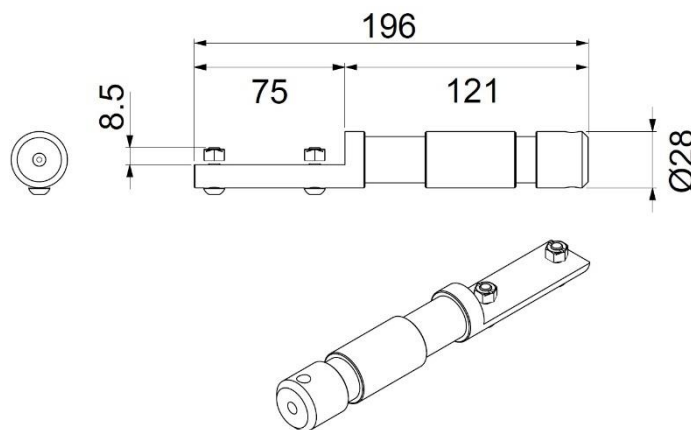

### VDO Sceptron XB Pivot Coupler

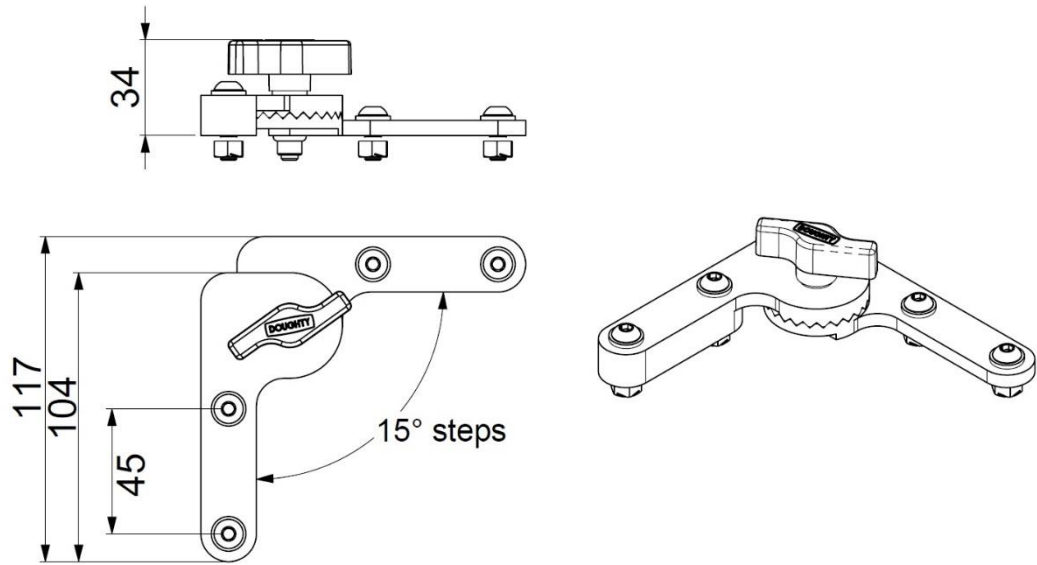

### VDO Sceptron XB Parallel Coupler 30/40/50 mm

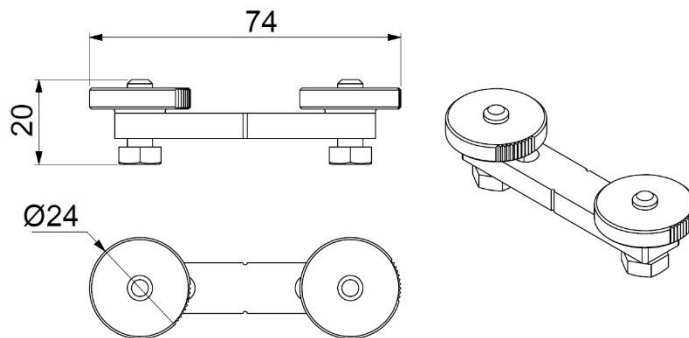

### VDO Sceptron XB Parallel Coupler 60/70/80mm

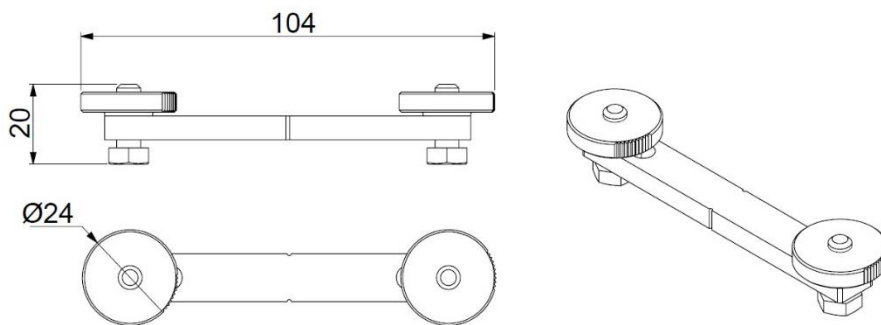

# Table of contents

Dimensions .....	2
Safety information .....	7
Precautions to avoid damage .....	13
Cleaning .....	13
Operating temperature precautions .....	13
Sealing unused connectors with blanking caps .....	13
Maintaining IP65 protection.....	13
Introduction .....	14
Before using the product for the first time .....	14
VDO Sceptron XB overview.....	15
Physical installation.....	16
Captive fasteners .....	17
Installing a safety cable.....	17
Installing a sliding bracket.....	17
Installing parallel couplers.....	19
Joining fixtures end-to-end.....	19
Using a Linear Aligner.....	20
Mounting a single fixture .....	21
Suspending a curtain of horizontally oriented fixtures .....	21
Mounting on a non-vertical structure or surface.....	23
Suspending a vertical column of fixtures .....	24
Installing and removing optical accessories.....	25
System installation .....	27
Maintenance.....	28
Cleaning .....	28
LED performance .....	28
Installing firmware .....	28

# Safety information



## WARNING!

Read the safety precautions in this manual before installing, operating or servicing this product.

The following symbols are used to identify important safety information on the product and in this manual:



**Warning!**

**Safety hazard.  
Risk of severe  
injury or death.**



**Warning!**

**Hazardous  
voltage. Risk of  
lethal or severe  
electric shock.**



**Warning!**

**Fire hazard.**



**Warning!**

**Burn hazard.  
Hot surface. Do  
not touch.**



**Warning!**

**Intense light  
emission.**



**Warning!**

**See user  
documentation.**



Warning! Read this Safety and Installation Manual before installing, powering or servicing the VDO Sceptron XB. Follow the safety precautions given in this manual, in the VDO Sceptron XB User Manual and in the manuals of all the devices you connect to the product. Observe all warnings given in manuals and printed on devices. Respect all locally applicable laws and regulations. Make sure that everyone who is involved in working on or using the product has read and understood these safety precautions and warnings.

This Safety and Installation Manual is supplied with the VDO Sceptron XB and available for download together with the VDO Sceptron XB User Manual from the Martin® website at [www.martin.com](http://www.martin.com). Check the Martin website and make sure that you have the latest revisions of the user documentation for all the devices in your installation. Martin user manual revisions are identified at the bottom of page 2.

Install, operate and service Martin products only as directed in their manuals, or you may create a safety hazard or cause damage that is not covered by product warranties. Keep this manual for future use.

The VDO Sceptron XB is for professional use and must be installed by a qualified technician. It is not for household use.

The safety and suitability of lifting equipment, installation location, anchoring method, mounting hardware and electrical installation are the responsibility of the installer.

Users may carry out external cleaning and install the accessories available from Martin following the instructions and warnings given in this manual, but any service operation not described in this manual or in the VDO Sceptron XB User Manual must be referred to an authorized Martin service agent. The light source contained in the VDO Sceptron XB is non-replaceable.

The VDO Sceptron XB is suitable for mounting at any height, including less than 1.2 m (3.9 ft.) and more than 5 m (16.4 ft.) above ground or floor level.

Do not operate the VDO Sceptron XB at an altitude of more than 2000 m (6570 ft.) above sea level.

### **Technical Support**

If you have any questions about how to install or operate the VDO Sceptron XB safely, please contact Harman Professional Technical support.

For technical support in N. America, please contact:

HProTechSupportUSA@harman.com

Phone: (844) 776-4899

For technical support outside North America, please contact your national distributor.



### **Protection from electric shock**

Read and respect the directions given in the user documentation of the VDO Sceptron XB and of all the devices that you intend to connect to it, particularly the instructions, limits and warnings that apply to:

- system layout
- connections to other devices,
- specified cables,
- maximum cable lengths, and
- maximum number of devices that can be connected.

Connect the VDO Sceptron XB system only to the devices specified in the VDO Sceptron XB user documentation and only as directed in that documentation.

Use only the cables specified in the VDO Sceptron XB user documentation and on the Martin website at [www.martin.com](http://www.martin.com) to interconnect devices in the installation. If the specified cables are not long enough for an intended cable run, consult Martin for assistance in finding or creating a safe alternative solution.

Provide a means of locking out AC mains power so that power to the installation can be shut down and made impossible to reapply, even accidentally, during work on the installation.

Shut down power to the installation at the main power distribution board and lock out power before carrying out any installation or maintenance work.

Shut down power to the installation when it is not in use.

Before using the VDO Sceptron XB, check that all power distribution equipment and cables are in perfect condition, are rated for the current requirements of all connected devices, are protected to IP65 or higher and are of suitable type for the location (including water, pollution, temperature and UV resistance).

Isolate the installation from power immediately if any product, cable, connector, seal, cover or other component is damaged, defective, deformed or showing signs of overheating. Do not reapply power until repairs have been completed.

The VDO Sceptron XB is IP65-rated. It is suitable for temporary or permanent indoor use and temporary outdoor use, but do not immerse it in water or install it in a location where it may become submerged. Ensure sufficient drainage to cope with the heaviest rainfall. Make sure that water can drain away from the installation area at least as fast as it can enter it.

Arrange cables so that they arrive at connectors from below. Create a 'drip loop' if necessary. With this arrangement, gravity will cause any condensation or water droplets to run away from connectors.

Install a DCE connector sealing cap (available from Martin as an accessory) on the DCE cable at the end of each chain of VDO Sceptron XB fixtures.

Support the weight of cable runs. Do not allow a length of cable to hang from a VDO Sceptron XB fixture or connector.

The VDO Sceptron XB must be connected to power only as described in this manual. It accepts 48 VDC power from one of the following devices:

- Martin P3 PowerPort 2000,
- Martin P3 PowerPort 500 IP Rental,
- Martin P3 PowerPort 500 IP Install,
- Martin DCE PSU 240 IP, or
- suitable generic 48-volt PSU.

When creating a VDO Sceptron XB installation, respect carefully the safety limits and instructions in the user documentation of the above products.

### **Power characteristics**

VDO Sceptron XB devices have the following power characteristics:

#### **1000 mm variant**

- DC voltage: 48 VDC +/- 4%
- Typical total power consumption (at full intensity, full white):
  - 30.0 W (full power mode)
  - 16.9 W (half power mode)
- Idle power consumption: 3.3 W
- Hibernation power consumption: 1.6 W

#### **320 mm variant**

- DC voltage: 48 VDC +/- 4%
- Typical total power consumption (at full intensity, full white):
  - 10.4 W (full power mode)
  - 6.5 W (half power mode)
- Idle power consumption: 2.2 W
- Hibernation power consumption: 1.6 W

If the cable length between the P3 PowerPort and the first VDO Sceptron XB exceeds 70 m (230 ft.), use a Martin DCE Data Splitter/Booster IP to amplify the data signal.

Likewise, if the cable length between any two VDO Sceptron XB fixtures exceeds 70 m (230 ft.), use a Martin DCE Data Splitter/Booster IP to amplify the data-signal

If you supply a chain of VDO Sceptron XB fixtures with DC power from a generic 48 VDC external PSU and the DC output used does not have constant overcurrent protection that limits current to 10 A, install an inline fuseholder with a 10 A fuse on the circuit that you connect to the DC output.

### **Martin P3 PowerPort safety limits**

If you supply VDO Sceptron XB fixtures with DC power from a Martin P3 PowerPort 2000 or P3 PowerPort 500:

- The P3 PowerPort 2000 has four DCE outputs and the P3 PowerPort 500 IP Install and Rental models have one DCE output.
- Outputs can be split using the DCE Data Splitter/Booster IP, but the total length of fixtures per P3 PowerPort output must not exceed the limits described in the safety limits table on the next page.
- Do not exceed the maximum total length of fixtures that you can include in one chain (see the safety limits table on the next page).

Total chain length	P3 PowerPort – Full-power Mode	P3 PowerPort – Half-power Mode	DCE PSU 240 IP – Full-power Mode	DCE PSU 240 IP – Half-power Mode
25 meters	12 meters of fixtures	21 meters of fixtures	6 meters of fixtures	10 meters of fixtures
50 meters	11 meters of fixtures	18 meters of fixtures	5 meters of fixtures	9 meters of fixtures
75 meters	9 meters of fixtures	15 meters of fixtures	5 meters of fixtures	9 meters of fixtures
100 meters	7 meters of fixtures	11 meters of fixtures	4 meters of fixtures	8 meters of fixtures
125 meters	5 meters of fixtures	9 meters of fixtures	4 meters of fixtures	7 meters of fixtures
150 meters	4 meters of fixtures	7 meters of fixtures	3 meters of fixtures	7 meters of fixtures
175 meters	3 meters of fixtures	6 meters of fixtures	3 meters of fixtures	6 meters of fixtures
200 meters	3 meters of fixtures	5 meters of fixtures	2 meters of fixtures	5 meters of fixtures

#### **Safety limits for length of VDO Sceptron daisy-chain**

The total chain length means the total length of cable and fixtures from the P3 PowerPort or DCE PSU to the END of the LAST fixture on the chain.

Where the table gives 'meters of fixtures' it means the number of meters of the chain that can be fixtures. For example, if the total chain length is 25 meters and you are supplying the chain with power using a P3 PowerPort in full-power mode, the chain can contain a maximum of 12 meters of fixtures (which would allow 13 meters of cable).

If any cable between a P3 PowerPort and a fixture or between two fixtures exceeds 70 meters (230 ft.), you must insert a Martin DCE Data Splitter/Booster IP unit to amplify the data signal.

#### ***Daisy chain limits below freezing point***

When using the fixture below 0°C in Full-power mode, reduce the number of fixtures per daisy chain by 20%.

When using the fixture below 0°C in Half-power mode, reduce the number of fixtures per daisy chain by 50%.

#### **Martin DCE PSU 240 IP safety limits**

If you supply VDO Sceptron XB fixtures with DC power from a Martin DCE PSU 240 IP, do not exceed the maximum lengths given in the safety limits table above.

#### **Generic 48 VDC external PSU safety limits**

If you wish to supply VDO Sceptron XB fixtures with DC power from a 48 V external PSU that you obtain yourself, obtain a power supply that can supply 5 A at 48 VDC and respect the maximum lengths given for the DCE PSU 240 IP running in full-power mode in the safety limits table above.



### Protection from eye injury

Do not stare directly into a VDO Sceptron XB device's light output.

Do not look at the light output with magnifiers, telescopes, binoculars or similar optical instruments that may concentrate the light output.

Ensure that nobody is looking directly into the front of a device when it lights up suddenly. This can happen when power is applied or when the device receives a control signal.

Provide well-lit conditions to reduce the pupil diameter of anyone working on or near the device.

Wear protective glasses when working on or near the device.



### Protection from burns and fire

Do not operate the fixture if the ambient temperature ( $T_a$ ) exceeds 55° C (131° F).

Keep flammable materials well away from the fixture. Keep all combustible materials (e.g. fabric, wood, paper) at least 0.2 m (8 in.) away from the fixture.



Ensure that there is free and unobstructed airflow around the fixture.

Use only optical accessories supplied by Martin for the fixture. Do not stick filters, masks or other materials onto the front of the fixture.

Do not attempt to bypass thermostatic switches or fuses.



### Protection from injury

Fasten the fixture securely to a fixed surface or structure when in use. The fixture is not portable when installed.

To reduce the risk of strangulation, all flexible wiring connected to the fixture shall be effectively fixed to the installation surface or structure if the wiring is within arm's reach.

The weight of a VDO Sceptron XB fixture not including diffusers, lenses or mounting hardware is as follows:

- VDO Sceptron XB 1000 mm: 1.6 kg (3.5 lb.)
- VDO Sceptron XB 320 mm: 0.6 kg (1.3 lb.)

If a fixture may cause injury or damage if it falls, secure it as described in this manual with a secondary attachment such as a safety cable that is approved by an official body such as TÜV as a safety attachment for the weight that it secures. The safety cable must comply with EN 60598-2-17 Section 17.6.6 or BGV C1 / DGUV 17 and it must also be capable of bearing a static suspended load at least ten times (or more if required by locally applicable regulations) the weight that it secures.

Use at least one safety cable per fixture: do not loop a safety cable through the bracket of more than one fixture.

Eliminate as much slack as possible from the safety cable (by looping it more than once around the rigging truss, for example). If the primary attachment fails, the safety cable must catch the fixture before the fixture has dropped 10 cm (4 in.).

Ensure that any supporting structure and/or hardware used can hold at least six (6) times (or more if required by local regulations) the weight of all the devices they support.

The safety and suitability of lifting equipment, installation location, anchoring method, mounting hardware and electrical installation are the responsibility of the installer.

Block access below the work area and work from a stable platform whenever installing, setting, adjusting, or cleaning the device.

All fasteners used to mount VDO Sceptron XB fixtures must be suitable for the application, corrosion resistant to suit the environment and strong enough to safely carry the load that they support.

After installation or service, check that all devices, accessories and rigging hardware items used are securely fastened in place.

Do not add more than three (3) flightcase extenders to one VDO Sceptron XB flightcase base unit.

Do not use the VDO Sceptron XB without an optical accessory installed on the front of the fixture as directed in this manual. Optical accessories for the VDO Sceptron XB are listed on the Martin website at [www.martin.com](http://www.martin.com)

In any location where an array of VDO Sceptron XB fixtures may be exposed to the wind, follow the precautions listed below as well as the instructions in the Physical Installation chapter of this manual. Ensure that professional technicians:

- are in attendance at the installation at all times,
- constantly monitor weather forecasts and local wind speed, and
- remove all fixtures from the installation immediately if constant or gusting wind speed that exceeds Force 8 on the Beaufort scale (74 km/h, 46 mph or 20 meters/sec.) is forecast or present at the installation location.

# Precautions to avoid damage

Important! To get the best out of the VDO Sceptron XB and avoid causing damage that is not covered by the product warranty, make sure that everyone who is involved in installing, working on or using the VDO Sceptron XB has read and understood the following information.

## Cleaning

Excessive dirt buildup causes overheating and may lead to damage that is not covered by the product warranty. Clean the product at regular intervals (see "Cleaning" on page 32).

## Operating temperature precautions

- Exposing the VDO Sceptron XB to direct sunlight or operating it in an ambient temperature lower than  $-30^{\circ}\text{C}$  ( $-22^{\circ}\text{F}$ ) or higher than  $55^{\circ}\text{C}$  ( $131^{\circ}\text{F}$ ) may reduce the lifetime of the product.
- VDO Sceptron XB fixtures have an internal thermal sensor. If the sensor detects excessive temperature, the fixture will gradually regulate light output and eventually shut down output completely. The fixture will function normally again when the temperature has fallen to a safe level.
- When using a Martin P3 System Controller you can enable "thermal throttling" functionality. This feature gradually dims all the fixtures in an installation if one or more fixtures begin to overheat, avoiding full thermal shutdowns.

## Sealing unused connectors with blanking caps

Blanking caps for male and female hybrid DCE connectors can be ordered separately from Martin. Install blanking caps on all unused DCE connectors to seal them against water and dirt, otherwise short-circuits and damage may occur.

## Maintaining IP65 protection

The VDO Sceptron XB is supplied as a sealed unit. Do not try to disassemble the product in any other way, or you will affect the product's IP65-rated weatherproofing. This may cause the product to malfunction and lead to damage that is not covered by the product warranty.

## Avoiding shocks and stress

Do not expose the VDO Sceptron XB to physical shocks (by dropping onto a hard surface, for example).

Do not apply pressure to or otherwise stress diffusers or lenses.

Do not stress cables (by bending them sharply, for example). Protect cables from sharp edges. Note that sub-zero temperatures cause stress in cable materials.

## Protecting from galvanic corrosion

The VDO Sceptron XB is corrosion-protected to C3 High according to EN ISO 12944-2, but take precautions to avoid direct contact between aluminum and other metals because this can cause galvanic corrosion:

- Use an electrically insulating material (such as rubber or plastic) or a protective coating between aluminum mounting profiles and any other metal.
- Use a non-conductive coating such as Delta Seal on fasteners (screws, bolts, washers, etc.) where they come into contact with VDO Sceptron XB fixtures or mounting profiles.

# Introduction

Thank you for selecting a VDO Sceptron XB lighting device from Martin®. This Safety and Installation Manual is supplied with each VDO Sceptron XB fixture. It gives details of installing and servicing the device as well as connecting to power. The VDO Sceptron XB User Manual, containing system diagrams and full instructions for setting up, controlling and monitoring devices, is available for download from the VDO Sceptron XB area of the Martin website at [www.martin.com](http://www.martin.com). System diagrams are also available for download separately. If you have any difficulty locating this information, your Martin supplier will be happy to help you.

Before installing, operating or servicing a VDO Sceptron XB fixture, please check the VDO Sceptron XB area of the Martin website at [www.martin.com](http://www.martin.com) and make sure that you have the latest user documentation for the fixture.

Not all product specifications are included in the fixture's user documentation. You can find full specifications for the fixture in the VDO Sceptron XB area of the Martin website. The online specifications include information to help you order accessories such as cables, P3 PowerPorts, external PSUs etc.

See the VDO Sceptron XB area of the Martin website at [www.martin.com](http://www.martin.com) for details of fixtures, accessories for the fixture and related products.

## Flightcases

Martin can supply flightcases for the VDO Sceptron XB. These are identical to the original VDO Sceptron flightcases but have new foam inserts in their lids to accept the slightly taller XB fixtures. Martin can supply the foam inserts for XB fixtures separately if you wish to re-use older flightcases.

## Before using the product for the first time

1. Read 'Safety information' at the beginning of this manual before installing, operating or servicing the VDO Sceptron XB.
2. Unpack the fixture. Please make sure to recycle packaging material.
3. Ensure that there is no transportation damage before using fixtures. Do not attempt to operate a damaged fixture.
4. Check the VDO Sceptron XB area of the Martin Professional website at [www.martin.com](http://www.martin.com) for the most recent user documentation and technical information about the fixture. Martin manual revisions are identified by the revision letter at the bottom of the inside cover.

# VDO Sceptron XB overview

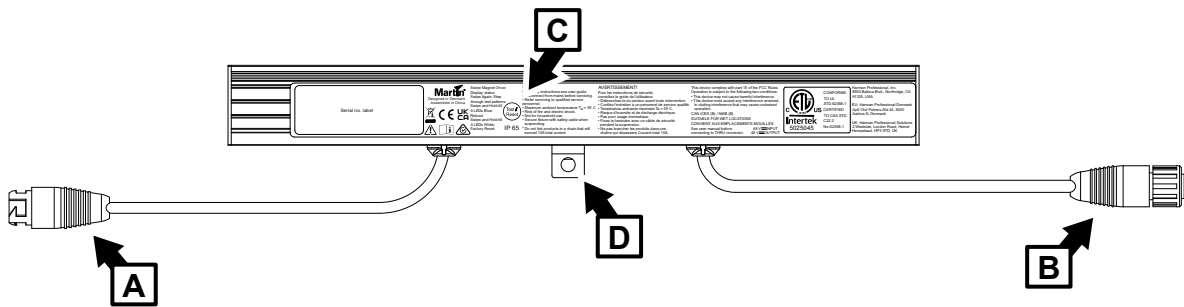

320 mm fixture illustrated

- A** - 48 VDC power + data DCE-type male input connector
- B** - 48 VDC power + data DCE-type female output (thru) connector
- C** - Magnetic control sensor (encased inside fixture) – can be activated using Martin magnetic multi-tool
- D** - Safety cable attachment point

# Physical installation



**Warning!** Read 'Safety information' on page 7 and 'Precautions to avoid damage' on page 13 before installing the VDO Sceptron XB.

Contact your Martin supplier for assistance if you have any questions about how to install this product safely.

VDO Sceptron XB fixtures are intended for temporary or permanent indoor and temporary outdoor use. With an IP65 rating, they are protected against dust, humidity and water and are able to withstand powerful water jets, but they are not submersible. Do not submerge the device and do not install it in a location where water can build up around the device. If necessary, provide drainage at the installation location.

Avoid stress on cables and tension at cable entries or connectors by supporting all cable runs with plenty of cable ties or similar supports that are suitable for the location, application and environment.

Allow free airflow around VDO Sceptron XB fixtures and allow at least 10 mm (0.4 in.) of clearance around the front surface.

Different installation methods and hardware are required depending on size of fixture, orientation, number of fixtures fastened together and conditions in the installation location (a) indoors on a static structure or (b) in a location that is exposed to wind, vibration or other forces. Read this chapter carefully before installing VDO Sceptron XB fixtures and use the method that is suitable for the installation site.

The VDO Sceptron XB is designed to withstand low-pressure water projections but is not designed for permanent installation in wet locations. Do not submerge it or expose it to high-pressure water jets.

The VDO Sceptron XB can be installed in any orientation. The most evenly matched optical characteristics when viewing an installation from the side at an angle are obtained when all VDO Sceptron fixtures are oriented vertically, but unevenness will hardly be noticeable in horizontal strips, and then only when viewed from the side.

## Mounting surface or structure

Any structure or surface used to support VDO Sceptron XB fixtures must be stable and it must be capable of safely holding six times (or more if required by local regulations) the weight of all the items that it will support.

## Fasteners

All fasteners must be suitable for the application and environment. Steel fasteners must be grade 8.8 minimum according to ISO 898-1. Stainless steel fasteners must be grade 304 (A2) or better – and in marine environments stainless steel fasteners must be grade 316 (A4) or better – according to ISO 3506.

Use washers under the heads of all fasteners.

To minimize the risk of galvanic corrosion, apply a non-conductive coating such as Delta Seal to steel items that will come into contact with aluminum parts.

## Wind precautions

Wind can create a risk of serious or lethal injury and damage due to falling fixtures. Follow the instructions in this chapter carefully.

If fixtures are to be installed in a location where they can be exposed to wind force, take these precautions:

- Observe all locally applicable laws, regulations and codes regarding safety of structures and installations.
- Follow the instructions in this chapter for installing in locations that are exposed to wind. A location that is exposed to wind is not a stable location as defined in this manual.
- Suspend fixtures from a structure that is capable of holding the fixtures securely without any safety risk when fixtures are exposed to wind pressure.

- Ensure that weather forecasts and local wind speed are constantly monitored while the installation is in place.
- Ensure that all fixtures are removed from the installation immediately if constant or gusting wind speed exceeding Force 8 on the Beaufort scale (74 km/h, 46 mph or 20 meters/sec.) is forecast or present.

## Captive fasteners

A channel for M6 fasteners (bolt heads and nuts) is provided in the profile on the back of VDO Sceptron XB fixtures. See drawing on right. To fasten brackets etc. to a fixture, pass each fastener through the cutout next to the cable tail and slide it into the channel. The channel holds the fastener captive so that you can tighten against it.

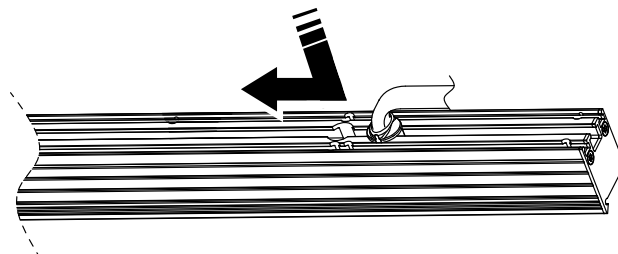

## Installing a safety cable

Safety cable attachment brackets and fasteners are supplied with fixtures. If you install a VDO Sceptron XB fixture in a location where it may cause injury or damage if it falls, you must install a safety cable bracket on the fixture and secure it with a secondary attachment (such as a safety cable) that will prevent the fixture from falling if the primary attachment fails.

To install a safety cable attachment bracket and safety cable:

1. Place the fixture with the LEDs facing downwards on a surface that will not scratch or damage the fixture.
2. See drawing on right. Slide the safety cable attachment bracket's nut into the channel in the back of the fixture. On 1000 mm fixtures, slide the nut until it is as close as possible to the center of the fixture.
3. Tighten the supplied Torx bolt into the nut to a torque of 8 Nm so that the safety cable attachment bracket is held securely.
4. Obtain a safety cable that is approved as a secondary attachment for the weight it will secure. Pass the safety cable through the bracket on the fixture.
5. As soon as you have fastened the fixture in the installation location, pass the safety cable through a secure anchoring point and secure the cable so that it will catch the fixture and prevent any injury or damage if the sliding brackets or other primary attachments fail.

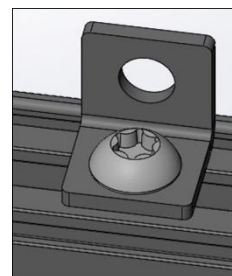

When installing multiple fixtures, you can loop one safety cable through the attachment brackets of more than one fixture and through the anchoring point, but only do this if:

- the safety cable is rated for the total weight it secures,
- the anchoring point can support at least ten times the weight it secures, and
- the arrangement will catch all the items supported and prevent injury or damage if the primary attachment fails.

## Installing a sliding bracket

Sliding brackets for the VDO Sceptron XB allow you to fasten fixtures to a truss using a rigging clamp or to a surface or other structure using M12 bolts passed through the bracket.

**In locations with stable conditions only** (i.e. no wind, movement, vibration or other forces) you can fasten the brackets to fixtures using the spring-loaded fasteners supplied with the brackets. **In all other situations** you must remove the supplied spring-loaded fasteners and fasten the brackets to fixtures using M6x16mm bolts and self-locking nuts. Read all of this chapter carefully for information about the requirements of different situations.

## Installing a sliding bracket with spring-loaded fasteners

To install a sliding bracket on a VDO Sceptron XB fixture using the supplied spring-loaded fasteners:

1. See drawing on right. Place the fixture with the LEDs facing downwards on a surface that will not scratch or damage the fixture. Push one of the spring-loaded mounting screws **B** on a bracket **A** down with your thumb so that the nut **C** on the screw is pushed down and away from the bracket.

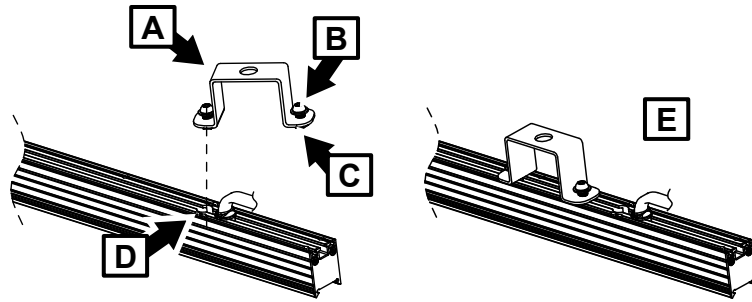

2. Pass the nut **C** through the cutout **D** in the rear of the fixture and into the channel in the rear of the fixture. Slide the nut towards the center of the fixture until you can pass the second nut in the bracket through cutout **D** while pressing down on the second spring-loaded screw.
3. Pressing down on both spring-loaded screws, slide the bracket towards the center of the fixture and release the screws. When you have finished, the bracket should be as shown at **E**, with both nuts securely held in the channel in the rear of the fixture.

Use at least one spring-loaded fastener to support 320 mm fixtures. Use at least two spring-loaded fasteners to support 1000 mm fixtures.

## Installing a sliding bracket with M6 bolts

To install a sliding bracket on a VDO Sceptron XB fixture using M6 bolts:

1. See drawing below. Remove the spring-loaded fasteners **F** from the sliding bracket, removing the two Torx screws with their washers, springs and self-locking nuts. Keep all these items safe for possible future use.

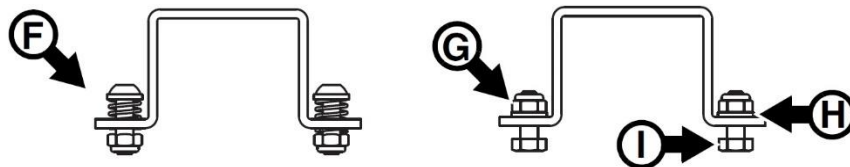

2. Install grade 8.8 strength M6x16mm bolts, washers and self-locking nuts **G** on the bracket. Put the washer between the nut and the sliding bracket at **H**.
3. Pass the bolt heads **I** through the cutout and into the channel in the rear of the fixture. When the bracket is in position, tighten the nuts **G** to a torque of 8 Nm.

## Reinstalling spring-loaded fasteners

**Warning! If you do not install the original washer between the head of each Torx screw and the spring when reinstalling spring-loaded fasteners, there is a danger that the fastener may fail.**

If you have replaced the spring-loaded fasteners on a sliding bracket with M6x16 bolts as described above, and you need to re-install the original spring-loaded fasteners:

1. See drawing above. Remove the M6 nuts **G**, washers **H** and bolts **I** from the bracket.
2. Reassemble the spring-loaded fasteners as shown at **F**. Install the original washer between the head of the screw and the spring. If you do not install the washer, there is a danger that the fastener may fail! Use a new grade 8.8 strength M6 self-locking nut. Hold the nut with a wrench/spanner while you tighten the screw to 1 Nm against the pressure from the spring.

## Installing parallel couplers

The parallel couplers available from Martin let you install fixtures parallel to each other in regularly spaced lines. The couplers are supplied with thumbscrews for fastening to fixtures. The drawing on the right shows the center-to-center spacings between parallel fixtures that you can obtain by passing the thumbscrews through different combinations of holes.

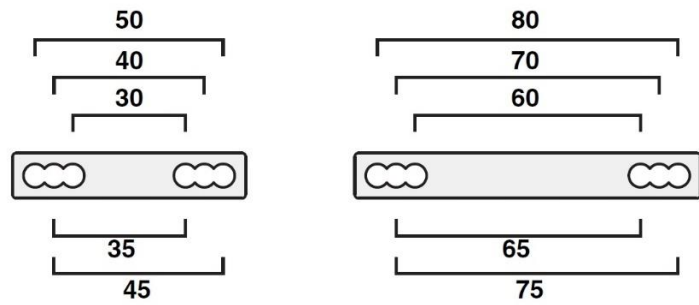

In locations **with stable conditions only** (i.e. no wind, movement, vibration or other forces), you can use the supplied thumbscrews to fasten fixtures parallel to each other. In **all other situations** you must remove the thumbscrews and fasten the couplers to fixtures using grade 8.8 strength M6x16mm bolts, washers and self-locking nuts. Read the instructions in this chapter for instructions that apply to different types of installation and different conditions.

To fasten a parallel coupler to a fixture:

1. Install a safety cable attachment bracket close to the center of the fixture as described on page 17.
2. Pass the coupler bolt head through the cutouts and into the channels in the rear of the two fixtures to be joined.
3. Depending on the instructions later in this chapter, fasten the coupler to the fixtures with either grade 8.8 strength M6x16mm bolts, washers and self-locking nuts or with the thumbscrews supplied with the couplers. See drawing below. Install parallel couplers (arrowed) as close as possible to the ends of fixtures, but allow space for sliding brackets.

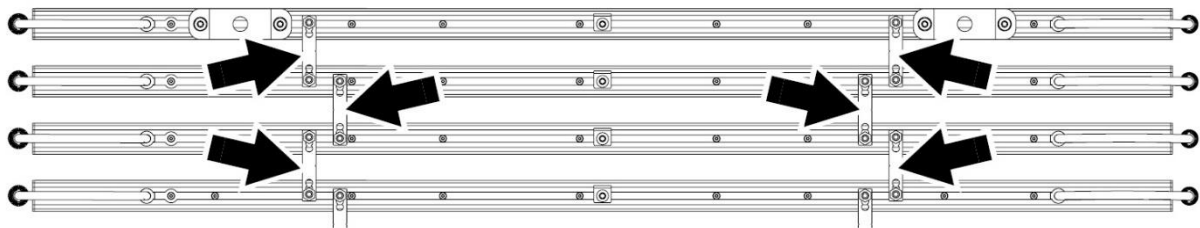

## Joining fixtures end-to-end

The Linear Coupler accessory available from Martin lets you fasten VDO Sceptron XB fixtures to each other end-to-end and suspend the fixtures in a vertical column. You can also use Linear Couplers to align multiple fixtures accurately in a straight line at any angle, but if you do this, each VDO Sceptron XB fixture must be fastened independently to a surface or structure.

Linear Couplers and VDO Sceptron XB profiles are strongly constructed, but you must not expose end-to-end joints to bending, shear or torsion stress. If you try to move the bottom of a vertical column of VDO Sceptron XB fixtures when the top fixture is fastened to a structure or surface and the other fixtures are hanging freely, you will apply a leverage force that can cause damage and can cause the column to break apart and fall. You may only use a Linear Coupler to support weight if you are hanging fixtures vertically downwards in a chain in stable conditions (i.e. in a location that is free of wind, vibration and movement). In all other situations, support the weight of each fixture independently so that no Linear Coupler is subjected to bending, shear or torsion stress.

See “Suspending a vertical chain of fixtures joined end-to-end” on page 24 for instructions on installing fixtures in a vertical column.

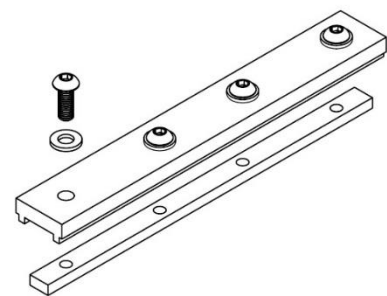

**VDO Sceptron XB Linear Coupler**

To join two fixtures using a Linear Coupler:

1. See drawing below. Slide the Linear Coupler into the channels in the rear of the fixtures and push the fixtures together until both fixtures meet in the center of the coupler.

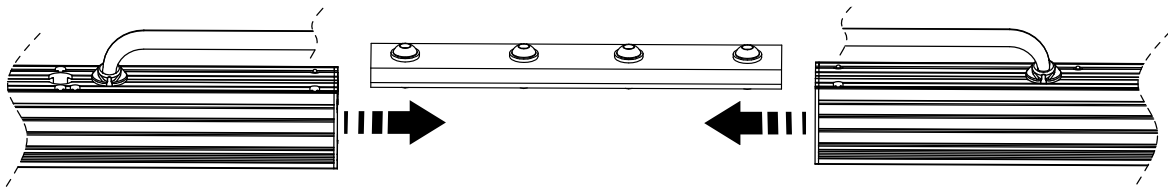

**Joining fixtures with a Linear Coupler**

2. Tighten all four Torx screws on the coupler to a torque of 6 Nm using a torque driver.

## Using a Linear Aligner

The Linear Aligner accessory available from Martin lets you align multiple fixtures accurately in a straight line at any angle, but if you do this, each VDO Sceptron XB fixture must be fastened independently to a surface or structure.

**Warning!** Do not use a Linear Aligner to support the weight of a fixture vertically or at any other angle. Support the weight of fixtures while you are installing Linear Aligners and while installing the fixtures. If you want to suspend multiple fixtures in a vertical column, use Linear Couplers to fasten them end-to-end as described in the previous section.

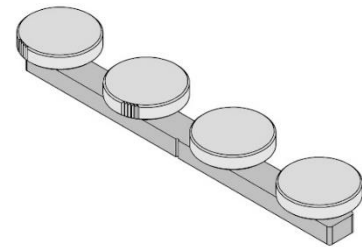

**VDO Sceptron XB Linear Aligner**

To align VDO Sceptron XB fixtures using Linear Aligners:

1. Install sliding brackets on the fixtures as described earlier in this chapter. Install at least one sliding bracket on 320 mm fixtures and at least two sliding brackets on 1000 mm fixtures
2. Install the first fixture securely on a surface or structure using its sliding bracket or brackets.
3. See drawing below. Supporting the weight of the second fixture, slide the Aligner into the channels in the rear of the fixtures and push the fixtures together until both fixtures meet in the center of the Aligner.

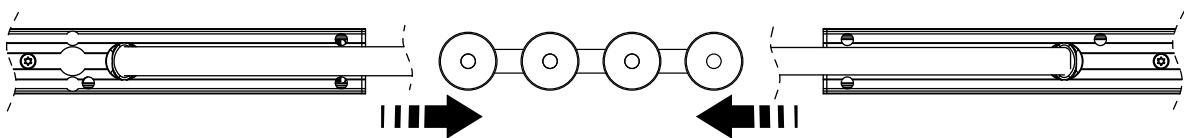

**Aligning fixtures with a Linear Aligner**

4. Continuing to support the weight of the second fixture, fasten it securely to the surface or structure using its sliding bracket or brackets, then tighten the four thumbscrews on the Linear Aligner by hand.
5. Continue adding VDO Sceptron XB fixtures as described for the second fixture.

## Mounting a single fixture

### **All conditions**

To mount a single 320 mm or 1000 mm fixture on a structure or surface in any orientation in a location that may be exposed to wind, vibration or other forces:

1. Install a safety cable attachment bracket close to the center of the fixture (see 'Installing a safety cable' on page 17).
2. Install two sliding brackets on a 1000 mm fixture or one sliding bracket on a 320 mm fixture using grade 8.8 M6x16mm bolts (see 'Installing a sliding bracket with M6 bolts' on page 18).
3. Pass a grade 8.8 strength M12 bolt through the hole in the center of each sliding bracket to fasten the fixture to a rigging clamp, surface or structure. Secure the bolt with a self-locking nut.
4. If you are installing the fixture in a location where it may cause injury or damage if it falls, secure the fixture with a safety cable as described in 'Installing a safety cable' on page 17.

### **Stable conditions only**

To mount a single 320 mm or 1000 mm fixture on a structure or surface in any orientation in a location with stable conditions (no wind or other forces, no vibration, fixed and rigid supporting structure):

1. Install a safety cable attachment bracket close to the center of the fixture (see 'Installing a safety cable' on page 17).
2. Install one sliding bracket in the center the fixture using spring-loaded fasteners (see 'Installing with spring-loaded fasteners on page 18).
3. Pass a suitably dimensioned grade 8.8 strength bolt through the hole in the sliding bracket to fasten the fixture to a rigging clamp (such as the Superlight half-coupler rigging clamp, black, P/N 91602018 from Martin), surface or structure. Secure the bolt with a self-locking nut.
4. If you are installing the fixture in a location where it may cause injury or damage if it falls, secure the fixture with a safety cable as described in 'Installing a safety cable' on page 17.

## Suspending a curtain of horizontally oriented fixtures

### **All conditions, 1000 mm fixtures**

To suspend horizontally oriented 1000 mm VDO Sceptron XB fixtures in a curtain in a location that may be exposed to wind, vibration or other forces:

1. Install a safety cable attachment bracket close to the center of each fixture (see 'Installing a safety cable' on page 17).
2. Install two sliding brackets on the top fixture and two on the bottom fixture using grade 8.8 M6x16mm bolts as described in 'Installing a sliding bracket with M6 bolts' on page 18. Use a torque wrench to tighten the bolts to a torque of 8 Nm.
3. You will need two parallel couplers each time you join two fixtures together. Remove the thumbwheels supplied with the parallel couplers and replace them with grade 8.8 strength M6 washers and self-locking nuts.
4. See drawing at top of next page. You can fasten up to a maximum of 10 fixtures to each in parallel lines using two parallel couplers **B** each time you join two fixtures together. Fasten the parallel couplers to fixtures using grade 8.8 strength M6x16mm bolts and self-locking nuts with washers (see 'Installing parallel couplers' on page 19). Use a torque wrench to tighten the bolts to a torque of 6 Nm. If you have joined ten fixtures in parallel lines using parallel couplers and you need to add more fixtures, you must start a new array of fixtures.
5. Use grade 8.8 strength M12 bolts and self-locking nuts to fasten the four sliding brackets **A** at the edges of the array to a stable structure that can safely hold the weight of all the items it must support.
6. If you are installing the fixtures in a location where they may cause injury or damage if they fall, secure each fixture with a safety cable as described in 'Installing a safety cable' on page 17.

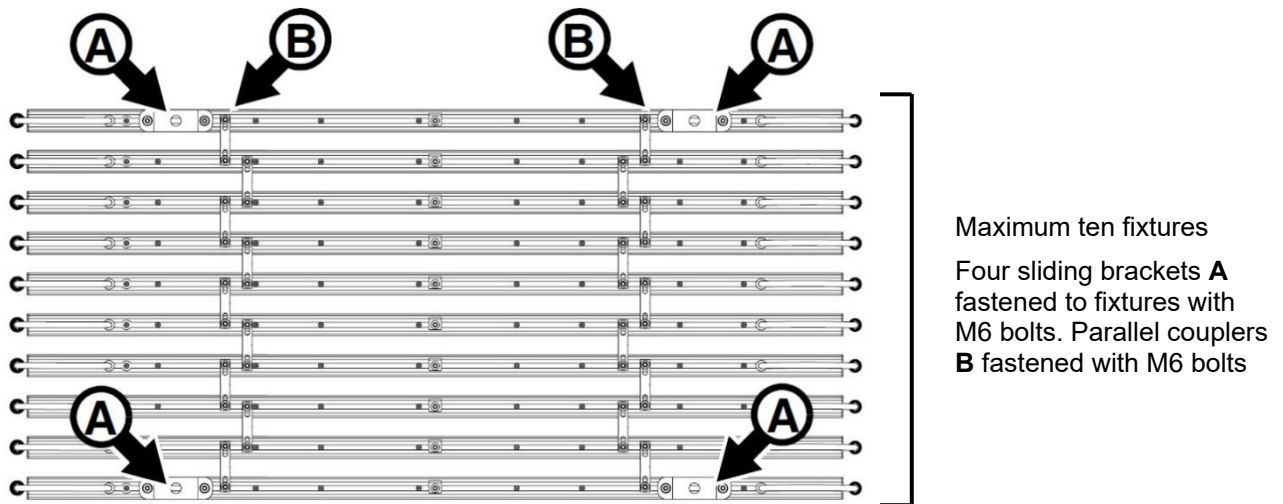

### **Stable conditions only, 1000 mm fixtures**

To suspend horizontally oriented 1000 mm VDO Sceptron XB fixtures in a curtain that is hanging vertically downwards in a location with stable conditions (no wind or other forces, no vibration, fixed and rigid supporting structure):

1. Install a safety cable attachment bracket close to the center of each fixture (see 'Installing a safety cable' on page 17).
2. See drawing below. Install two parallel couplers **B** on the top fixture (see 'Installing parallel couplers' on page 19).

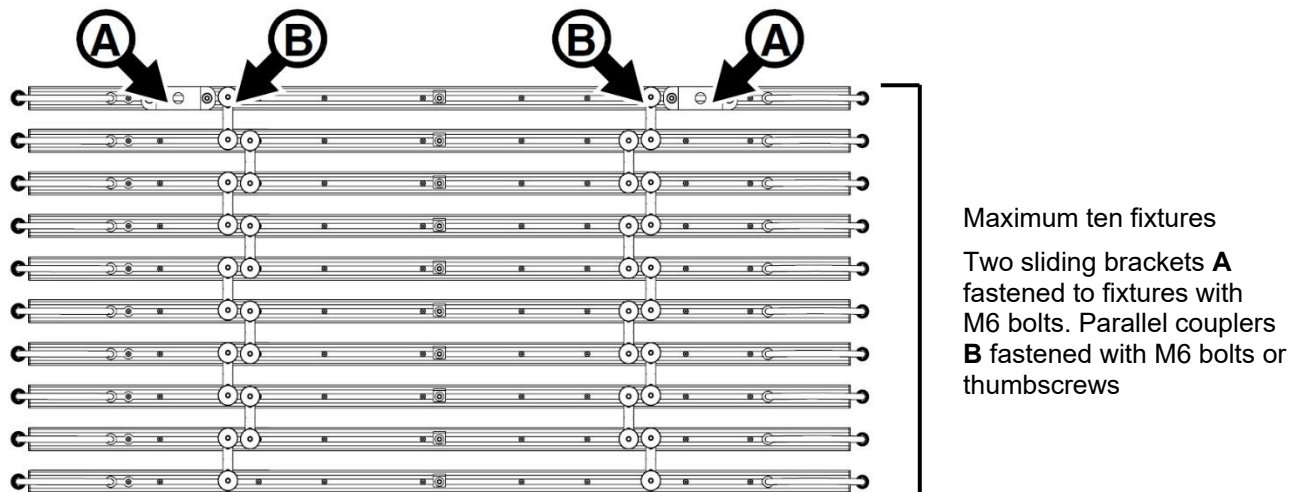

3. Install two sliding brackets **A** on the top fixture, fastening the brackets to the fixture using grade 8.8 M6x16mm bolts (see 'Installing a sliding bracket with M6 bolts' on page 18). Use a torque wrench to tighten the bolts to a torque of 8 Nm.
4. Continue fastening fixtures to each other with parallel couplers **B** up to a maximum of 10 fixtures. Use two parallel couplers **B** with thumbscrews or grade 8.8 strength M6x16mm bolts with washers and self-locking nuts each time you join two fixtures together.
5. Use grade 8.8 strength M12 bolts with washers and locking nuts passed through the holes in the sliding brackets to fasten the sliding brackets **A** to a stable structure that can safely hold the weight of all the items it must support.
6. If you are installing the fixtures in a location where they may cause injury or damage if they fall, secure each fixture with a safety cable as described in 'Installing a safety cable' on page 17.

## Mounting on a non-vertical structure or surface

### 1000 mm fixtures, all conditions

To mount or suspend 1000 mm VDO Sceptron XB fixtures on a structure or surface in any situation where fixtures are not horizontally oriented and linked in a curtain that is hanging vertically downwards:

1. Install a safety cable attachment bracket close to the center of each fixture (see “Installing a safety cable’ on page 17).
2. See drawing below. Each time you need to join two fixtures together, obtain two parallel couplers. Remove the thumbwheels supplied with the parallel couplers and replace them with grade 8.8 strength M6 washers and self-locking nuts.

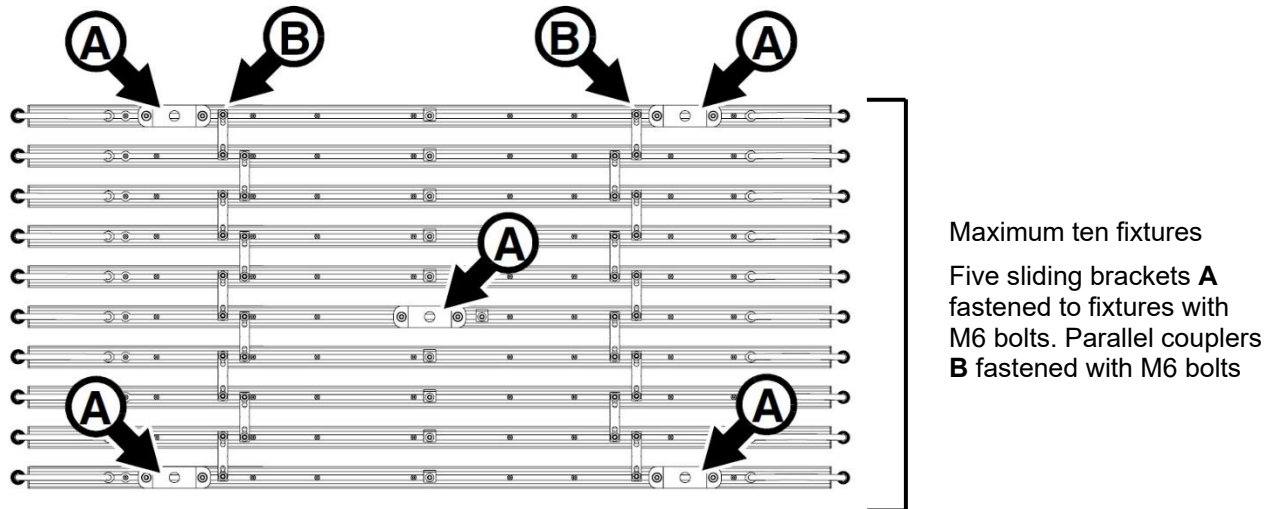

3. Fasten a maximum of 10 fixtures to each other as shown above using two parallel couplers **B** each time you join two fixtures together (see ‘Installing parallel couplers’ on page 19). Fasten the parallel couplers **B** to fixtures using M6 bolts and self-locking nuts. Use a torque wrench to tighten the nuts to a torque of 6 Nm. If you have joined ten fixtures as shown above and need to add more fixtures, you must start a new array of fixtures.
4. Install five sliding brackets **A** as shown above using grade 8.8 M6x16 bolts, washers and self-locking nuts (see ‘Installing a sliding bracket with M6 bolts’ on page 18).
5. Use grade 8.8 strength M12 bolts and self-locking nuts to fasten the brackets **A** to a stable structure that can safely hold the weight of all the items it must support.
6. If you are installing the fixtures in a location where they may cause injury or damage if they fall, secure each fixture with a safety cable as described in ‘Installing a safety cable’ on page 17.

**Warning!** Each array of fixtures joined together with parallel couplers must be supported by two sliding brackets installed on the first fixture and two sliding brackets installed on the last fixture. In groups containing from 6 to the maximum limit of 10 fixtures, you must also support the array with a sliding bracket installed at the center of the array as shown in the drawing above.

### 320 mm fixtures, all conditions

Mounting 320 mm fixtures is similar to the procedure for 1000 mm fixtures shown on the previous page, but only one sliding bracket **A** is required on each of the two outer fixtures, meaning that a total of three sliding brackets are required for an array containing maximum ten 320 mm fixtures.

To mount 320 mm VDO Sceptron XB fixtures on a structure or surface in any situation where fixtures are not horizontally oriented and linked in a curtain that is hanging vertically downwards:

1. Install a safety cable attachment bracket close to the center of each fixture (see ‘Installing a safety cable’ on page 17).
2. Each time you need to join two fixtures together, obtain two parallel couplers. Remove the thumbwheels supplied with the parallel couplers and replace them with grade 8.8 strength M6 washers and self-locking nuts.

3. Fasten a maximum of 10 fixtures to each other using two parallel couplers each time you join two fixtures together (see 'Installing parallel couplers' on page 19). Fasten the parallel couplers to fixtures using the M6 bolts and self-locking nuts. Use a torque wrench to tighten to a torque of 6 Nm. If you have joined ten fixtures and need to add more fixtures, you must start a new array of fixtures.
4. Install three sliding brackets using M6 bolts and self-locking nuts (see 'Installing a sliding bracket with M6 bolts' on page 18), fastening one bracket to each of the two fixtures at the sides of the array and one bracket at the center of the array.
5. Use grade 8.8 strength M12 bolts and self-locking nuts to fasten the three brackets to a stable structure that can safely hold the weight of all the items it must support.
6. If you are installing the fixtures in a location where they may cause injury or damage if they fall, secure each fixture with a safety cable as described in 'Installing a safety cable' on page 17.

## Suspending a vertical column of fixtures

You can install a vertical column of VDO Sceptron XB fixtures joined end-to-end that can be up to 6 meters tall. The column of fixtures must be mounted on a structure or surface using VDO Sceptron XB sliding brackets. The fixtures must be joined together using VDO Sceptron XB Linear Coupler accessories.

### **1000 mm and 320 mm fixtures, all conditions**

To suspend a column of VDO Sceptron XB fixtures hanging vertically:

1. Install a safety cable attachment bracket close to the center of each fixture (see 'Installing a safety cable' on page 17).

2. See drawing on right. You will need one Linear Coupler **C** each time you join two fixtures together, and you will need a minimum of one sliding bracket **A** for each fixture. Remove the spring-loaded fasteners from the sliding brackets and replace them with grade 8.8 strength M6 washers and self-locking nuts.

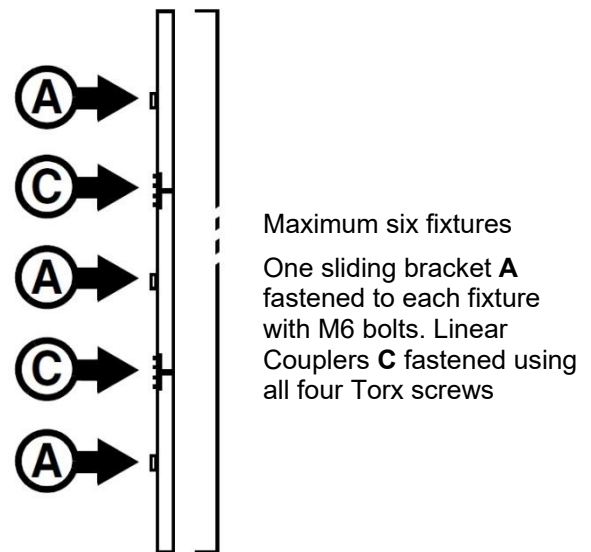

3. Install the sliding brackets **A** on the fixtures using M6 bolts, washers and nuts (see 'Installing a sliding bracket with M6 bolts' on page 18). Use a torque wrench to tighten nuts to a torque of 8 Nm.

4. Install the top fixture on the surface or structure, fastening it securely using an M12 fastener passed through the sliding bracket.

5. You can continue adding VDO Sceptron XB fixtures to the column up to a maximum of six fixtures total in the column. Use a VDO Sceptron XB Linear Coupler **C** each time you join two fixtures together (see 'Joining fixtures end-to-end' on page 19). Fasten the Linear Couplers **C** to fixtures by fastening all four Torx screws on each fastener. Use a torque driver to tighten all four screws to a torque of 6 Nm. Use the sliding bracket **A** to fasten the fixture to the surface or structure each time you add a new fixture.

6. If the array will cause injury or damage if it falls, secure each fixture independently with a safety cable as described in 'Installing a safety cable' on page 17.

7. If you reach the limit of 6 fixtures and need to continue creating a vertical column of fixtures, start a new column and install it separately in continuation of the first column.

### **1000 mm and 320 mm fixtures, stable conditions only**

To suspend a chain of VDO Sceptron XB fixtures hanging vertically in a location with stable conditions (no wind or other forces, no vibration, fixed and rigid supporting structure):

1. Install a safety cable attachment bracket close to the center of each fixture (see 'Installing a safety cable' on page 17).

- See drawing on right. You will need one VDO Sceptron XB Linear Coupler **C** each time you join two fixtures together and two sliding brackets **A** for the top fixture. Remove the spring-loaded fasteners from the sliding brackets and replace them with grade 8.8 strength M6 washers and self-locking nuts (see 'Installing a sliding bracket with M6 bolts' on page 18).
- Install the two sliding brackets **A** on the top fixture using M6 bolts, washers and nuts (see "Installing a sliding bracket" on page 17). Use a torque wrench to tighten nuts to a torque of 8 Nm.
- Fasten the top fixture securely to the surface or structure using an M12 fastener passed through the sliding brackets.
- If the array will cause injury or damage if it falls, secure each fixture independently with a safety cable as described in 'Installing a safety cable' on page 17.
- You can continue adding VDO Sceptron XB fixtures to the column up to a maximum of six fixtures total in the column. Use a VDO Sceptron XB Linear Coupler **C** each time you join two fixtures together (see 'Joining fixtures end-to-end' on page 19). Fasten the Linear Couplers **C** to fixtures by fastening all four Torx screws on each fastener. Use a torque driver to tighten all four screws to a torque of 6 Nm.
- If you reach the limit of 6 fixtures and need to continue creating a vertical column of fixtures, start a new column of fixtures and install it separately in continuation of the first column.

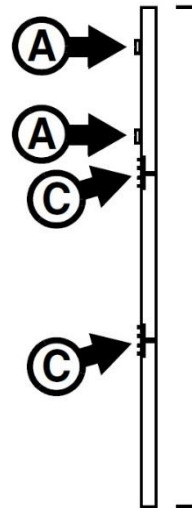

Maximum six fixtures  
Two sliding brackets **A** fastened to top fixture with M6 bolts. End-to-end couplers **C** fastened with M6 bolts

## Installing and removing optical accessories

The VDO Sceptron XB must be used with an optical accessory (clip-on diffuser or lens) installed on the front of the fixture. A wide range of these accessories is available from Martin (see The VDO Sceptron XB pages at [www.martin.com](http://www.martin.com)). They clip onto the front of fixtures and can be installed and removed in seconds.

To aid removal of optical accessories, we recommend that you use one of the two solutions available from Martin for the VDO Sceptron XB: either the Magnetic Swiper Test Tool or the Lens Removal Insert jaws that can be clipped onto pipe grips. See [www.martin.com](http://www.martin.com) or ask your Martin supplier for details.

To install an optical accessory:

- Block access below the work area and work from a stable platform.
- See drawing on right. Push one side of the diffuser / lens into the front of the fixture, then push the other side down also so that both sides are clipped into place.

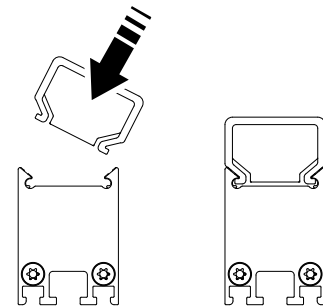

To remove an optical accessory:

1. Block access below the work area and work from a stable platform.
2. Install the Lens Removal Insert jaws available from Martin on a pair of pipe grips (see photo below) and grip the diffuser/lens as shown.

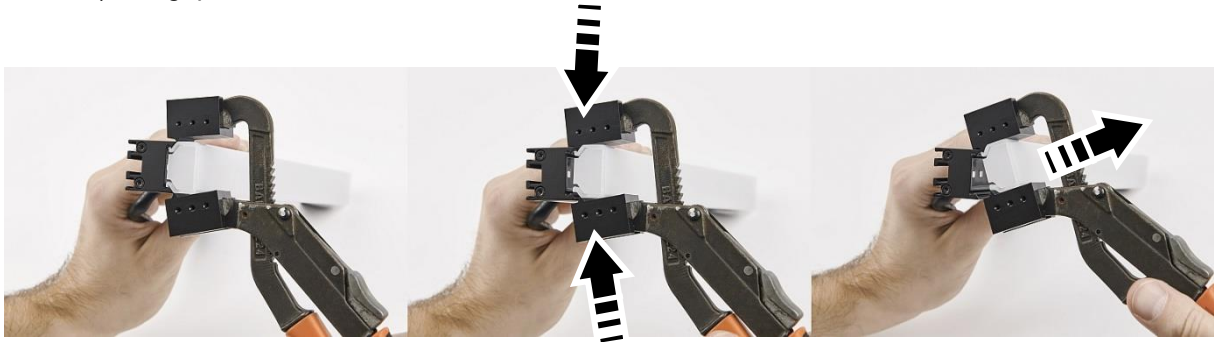

**Martin Lens Removal Insert jaws installed on a pair of pipe grips**

3. It is also possible to press the lever ends of two Martin Magnetic Swiper Test Tools between the diffuser / lens and the fixture (see drawing on right – we recommend using two Test Tools). Lever the diffuser carefully out of its clip and lift it away from the fixture.

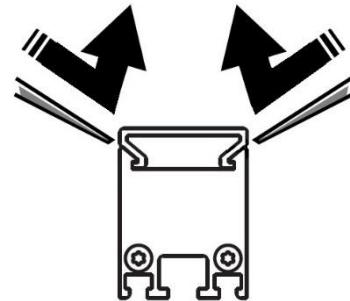

# System installation



**Warning!** Read 'Safety information' on page 7 and 'Precautions to avoid damage' on page 13 before connecting VDO Sceptron XB devices to DC power and data.



**Warning!** Connect the VDO Sceptron XB only to the devices and using only the Martin cables specified in this manual and in the VDO Sceptron XB User Manual that is available for download from the Martin website at [www.martin.com](http://www.martin.com).

**Warning!** Do not exceed the maximum numbers of devices that can be connected in chains and maximum cable lengths specified in 'Safety information' on page 7 and in the manuals of the other devices in the system.

The VDO Sceptron XB system is designed to work with lighting control via Art-Net / sACN, and to work with video control via Martin P3. The fixtures automatically recognize and respond to Art-Net, sACN, Martin P3 and RDM over Art-Net.

See the VDO Sceptron XB User Manual available for download from the VDO Sceptron XB area of [www.martin.com](http://www.martin.com) for details of setting up and using lighting control, video control, or both at the same time.

## Connecting a VDO Sceptron XB installation

See the VDO Sceptron XB User Manual and the detailed system diagrams available for download from the VDO Sceptron XB area of the Martin website at [www.martin.com](http://www.martin.com) for details of connecting and setting up a VDO Sceptron XB system.

To connect chains of VDO Sceptron XB devices:

1. Make sure that no devices in the installation can be connected to AC mains power until all installation work is complete.
2. Connect VDO Sceptron XB devices together in chains either directly using the hybrid DCE connectors on the devices' cable tails or by adding DCE-to-DCE hybrid extension cables with DCE connectors available from Martin (see the VDO Sceptron XB area of the Martin website at [www.martin.com](http://www.martin.com) for ordering information).

**Warning!** Do not exceed the maximum number of devices per chain given in 'Protection from electric shock' on page 8.

3. Install sealing caps available from Martin (see the VDO Sceptron XB area of the Martin website at [www.martin.com](http://www.martin.com) for ordering information) on the end of all DCE cables to protect connections from moisture, dirt etc.

## Data and DC power source

Connect chains of VDO Sceptron XB fixtures to control data and DC power at 48 volts from one of the following Martin devices only:

- Martin P3 PowerPort 2000,
- Martin P3 PowerPort 500 IP Rental,
- Martin P3 PowerPort 500 IP Install,
- Martin DCE PSU 240 IP, or
- suitable generic 48-volt PSU.

You can also use the *DCE Data Splitter/Booster IP* from Martin to split or extend DCE cable runs.

Respect all safety limits and follow the instructions in the user documentation of the above devices and all other devices when setting up the system.

# Maintenance



**Warning! Read ‘Safety information’ on page 7 before carrying out service or maintenance. There are no user-serviceable parts inside. Do not open the housing. Refer any service operation not described in this manual to Martin Professional or its authorized service agents.**

Installation, on-site service and maintenance can be provided worldwide by the Martin Professional Global Service organization and its approved agents, giving owners access to Martin’s expertise and product knowledge in a partnership that will ensure the highest level of performance throughout the product’s lifetime. Please contact your Martin® supplier for details.

Be aware that the output of LEDs, like all light sources, changes gradually over many thousands of hours of use. If you require products to perform to very precise color specifications, you may eventually need to make small readjustments at the lighting controller.

## Cleaning

Regular cleaning is essential for service life and performance. Buildup of dust and dirt will reduce the VDO Sceptron XB’s light output and cooling ability.

Cleaning schedules will vary greatly depending on the operating environment. It is therefore impossible to specify precise cleaning intervals for the VDO Sceptron XB. Inspect devices within their first few weeks of operation to see whether cleaning is necessary. Check again at frequent intervals. This procedure will allow you to assess cleaning requirements in your particular situation. If in doubt, consult your Martin dealer about a suitable maintenance schedule.

Do not use products that contain solvents, abrasives or caustic agents for cleaning, as they can cause surface damage. The aluminum housing and front glass can be cleaned with mild detergents such as those for washing cars.

To clean the housing:

1. Isolate the installation from power and allow the fixture to cool for 20 minutes.
2. Visually check that the fixture, seals and cables are in good condition. If any seal or cable shows signs of damage, cracking or loss of water resistance, stop cleaning the device and contact a Martin authorized service technician for replacement.
3. Rinse off loose dirt with a hose or low-pressure water spray.
4. Wash the aluminum housing using warm water with a little mild detergent and a soft brush or sponge. Do not use abrasive cleaners.
5. Rinse with clean water and wipe dry.

## LED performance

Martin use the best components available, but the characteristics of all LEDs change gradually over many thousands of hours of use. Not all colors change at the same rate, and rates of change vary depending on factors such as temperature and how intensively a particular color is used. Because of the changes, overall light output and the exact hues obtained from specific color mixes in all LED-based products can be expected to shift slightly over time.

To help you obtain consistent output despite these changes, Martin P3 software from version 4.1.0 contains the P3 Fixture Adjuster tool. This feature lets you compensate for changes in LED characteristics and restore initial output and color authenticity levels. Please contact Martin for more details.

## Installing firmware

It may be necessary to upload new firmware (i.e. device software) to the VDO Sceptron XB if you want to update to a newer firmware version or it appears to have a software-related fault.

You can check the currently installed firmware version of a VDO Sceptron XB using an RDM tool such as Martin Companion or a Martin P3 System Controller. The same firmware is used in both 320 mm and 1000 mm fixtures.

Firmware updates are available from the Martin website and can be downloaded automatically from within the Martin Companion software suite on a PC connected to the Internet. You can install firmware updates using Martin Companion or a P3 system controller connected to the VDO Sceptron XB fixtures. If you connect to a chain of VDO Sceptron XB fixtures that are all powered on, you can update the firmware in all the fixtures in one operation.

**Important!** Do not switch off the P3 PowerPort or disconnect the source of the firmware during an update, or the firmware will be corrupted.

### **Installing using a PC running Martin Companion**

The following are required in order to install firmware using a PC:

- A Windows PC running the latest version of the Martin Companion application (available for download free of charge from the Martin website at [www.martin.com](http://www.martin.com)).
- The VDO Sceptron XB firmware file (the Martin Companion application will download this file automatically when you run Martin Companion on a PC with an Internet connection).
- A network cable with RJ45 connectors to connect the PC running Martin Companion to the P3 PowerPort that is connected to the VDO Sceptron XB fixture or chain of VDO Sceptron XB fixtures.

To install firmware in the VDO Sceptron XB using Martin Companion:

1. Connect your PC to the Internet and launch the Martin Companion application. The application will automatically download the latest device firmware from the Martin cloud.
2. Read the firmware release notes carefully to check for any instructions or warnings.
3. Connect the PC running Martin Companion to the P3 PowerPort that is connected to the VDO Sceptron XB fixture(s) using a standard network cable with RJ45 connectors:
  - You can connect this cable to the Ethernet ports on the P3 PowerPort 2000 and P3 PowerPort 500 IP Rental devices directly or connect it to the control data link at some convenient point upstream of these devices.
  - Since the P3 PowerPort 500 IP Install does not have Ethernet ports, it is easiest if you connect your PC to the control data link at a convenient point upstream of the device. For workshop use, you can connect a network cable temporarily to the terminals inside the connections compartment following the instructions in the P3 PowerPort 2000/500 IP User Manual.
4. Carry out a firmware upload from within the Martin Companion application (see the application's help files if necessary). Do not disconnect the Martin Companion network cable until the upload is complete.

### **Installing from a P3 System Controller**

To install firmware in the VDO Sceptron XB using a Martin P3 System Controller:

1. Download the latest VDO Sceptron XB firmware file automatically from the Martin cloud using the Martin Companion application running on a PC connected to the Internet.
2. Import the firmware into the P3 System Controller. When you import new firmware into a P3 System Controller, it will automatically recognize old firmware in the connected VDO Sceptron XB fixtures and suggest a firmware update.
3. Use the P3 System Controller to upload the firmware to all the VDO Sceptron XB fixtures that are connected to the P3 System Controller and powered on.

When carrying out firmware updates, the P3 System Controller must be connected to VDO Sceptron XB fixtures as normal. Updating the firmware is a fairly intuitive process using the commands available in the controller interface. Any VDO Sceptron XB fixtures that are powered on will recognize that the P3 System Controller is offering a firmware update and prepare to receive the firmware.

## Specifications

For full product specifications, see the VDO Sceptron XB area of the Martin website at [www.martin.com](http://www.martin.com).

## FCC compliance

This equipment has been tested and found to comply with the limits for a Class B digital device, pursuant to part 15 of the FCC Rules. These limits are designed to provide reasonable protection against harmful interference in a residential installation. This equipment generates, uses and can radiate radio frequency energy and, if not installed and used in accordance with the instructions, may cause harmful interference to radio communications. However, there is no guarantee that interference will not occur in a particular installation. If this equipment does cause harmful interference to radio or television reception, which can be determined by turning the equipment off and on, the user is encouraged to try to correct the interference by one or more of the following measures:

- Reorient or relocate the receiving antenna.
- Increase the separation between the equipment and receiver.
- Connect the equipment into an outlet on a circuit different from that to which the receiver is connected.
- Consult the dealer or an experienced radio/TV technician for help.

## FCC Supplier's Declaration of Conformity

This device complies with part 15 of the FCC Rules. Operation is subject to the following two conditions:

1. This device may not cause harmful interference, and
2. this device must accept any interference received, including interference that may cause undesired operation.

## Canadian Interference-Causing Equipment Regulations – Règlement sur le Matériel Brouilleur du Canada

This Class B digital apparatus meets all requirements of the Canadian Interference-Causing Equipment Regulations. *Cet appareil numérique de la classe B respecte toutes les exigences du Règlement sur le Matériel Brouilleur du Canada.*

CAN ICES (B) / NMB (B)

## EU Declaration of Conformity

An EU Declaration of Conformity covering this product is available for download from the VDO Sceptron XB area of the Martin website at [www.martin.com](http://www.martin.com).

## Disposing of the product



Martin products are supplied in compliance with Directive 2012/19/EC of the European Parliament and of the Council of the European Union on WEEE (Waste Electrical and Electronic Equipment), where applicable.

Help preserve the environment! Ensure that this product is recycled at the end of its life. Your supplier can give details of local arrangements for the disposal of Martin products



